



SLOVENSKI STANDARD
SIST EN 300 175-8 V1.9.1:2006

01-marec-2006

8 [[]HJbY]nVc`ýUbYVfYnj fj] bYhY_Y ca i b]_UWYfB 97 HLÉ`G_i db]`j a Ygb]_`f7 ÷É
, "XY.`?cX]fUbY`]b`dfYbcg[cj cfU

Digital Enhanced Cordless Telecommunications (DECT); Common Interface (CI); Part 8:
Speech coding and transmission

iTeh STANDARD PREVIEW
(standards.iteh.ai)

[SIST EN 300 175-8 V1.9.1:2006](https://standards.iteh.ai/catalog/standards/sist/d740ec23-f32f-4ca6-bcaf-a33623f1aeb0/sist-en-300-175-8-v1-9-1-2006)

[https://standards.iteh.ai/catalog/standards/sist/d740ec23-f32f-4ca6-bcaf-](https://standards.iteh.ai/catalog/standards/sist/d740ec23-f32f-4ca6-bcaf-a33623f1aeb0/sist-en-300-175-8-v1-9-1-2006)

[a33623f1aeb0/sist-en-300-175-8-v1-9-1-2006](https://standards.iteh.ai/catalog/standards/sist/d740ec23-f32f-4ca6-bcaf-a33623f1aeb0/sist-en-300-175-8-v1-9-1-2006)

Ta slovenski standard je istoveten z: EN 300 175-8 Version 1.9.1

ICS:

33.070.30 Öã äæ) ^/á à[|zæ) ^ Digital Enhanced Cordless
à!^: ç|çã} ^/é ^\ [{ ~ } ä æä Telecommunications (DECT)
ÇÖÓVD

SIST EN 300 175-8 V1.9.1:2006 en

iTeh STANDARD PREVIEW
(standards.iteh.ai)

SIST EN 300 175-8 V1.9.1:2006

<https://standards.iteh.ai/catalog/standards/sist/d740ec23-f32f-4ca6-bcaf-a33623f4aeb0/sist-en-300-175-8-v1-9-1-2006>

ETSI EN 300 175-8 V1.9.1 (2005-09)

European Standard (Telecommunications series)

Digital Enhanced Cordless Telecommunications (DECT); Common Interface (CI); Part 8: Speech coding and transmission

iTeh STANDARD PREVIEW
(standards.iteh.ai)

[SIST EN 300 175-8 V1.9.1:2006](https://standards.iteh.ai/catalog/standards/sist/d740ec23-f32f-4ca6-bcaf-a33623f4eb0/sist-en-300-175-8-v1-9-1-2006)

<https://standards.iteh.ai/catalog/standards/sist/d740ec23-f32f-4ca6-bcaf-a33623f4eb0/sist-en-300-175-8-v1-9-1-2006>



Reference

REN/DECT-000233-8

Keywords

DECT, radio**ETSI**

650 Route des Lucioles
F-06921 Sophia Antipolis Cedex - FRANCE

Tel.: +33 4 92 94 42 00 Fax: +33 4 93 65 47 16

Siret N° 348 623 562 00017 - NAF 742 C
Association à but non lucratif enregistrée à la
Sous-Préfecture de Grasse (06) N° 7803/88

iTeh STANDARD PREVIEW
(standards.iteh.ai)

SIST EN 300 175-8 V1.9.1:2006<https://standards.iteh.ai/catalog/standards/sist/d740ec23-f32f-4ca6-bcaf-a33623f4ac6a/sist-en-300-175-8-v1-9-1-2006>**Important notice**

Individual copies of the present document can be downloaded from:

<http://www.etsi.org>

The present document may be made available in more than one electronic version or in print. In any case of existing or perceived difference in contents between such versions, the reference version is the Portable Document Format (PDF). In case of dispute, the reference shall be the printing on ETSI printers of the PDF version kept on a specific network drive within ETSI Secretariat.

Users of the present document should be aware that the document may be subject to revision or change of status. Information on the current status of this and other ETSI documents is available at

<http://portal.etsi.org/tb/status/status.asp>

If you find errors in the present document, please send your comment to one of the following services:

http://portal.etsi.org/chaicor/ETSI_support.asp

Copyright Notification

No part may be reproduced except as authorized by written permission.
The copyright and the foregoing restriction extend to reproduction in all media.

© European Telecommunications Standards Institute 2005.
All rights reserved.

DECT™, **PLUGTESTS™** and **UMTS™** are Trade Marks of ETSI registered for the benefit of its Members.
TIPHON™ and the **TIPHON logo** are Trade Marks currently being registered by ETSI for the benefit of its Members.
3GPP™ is a Trade Mark of ETSI registered for the benefit of its Members and of the 3GPP Organizational Partners.

Contents

Intellectual Property Rights	6
Foreword.....	6
1 Scope	7
2 References	7
3 Symbols and abbreviations.....	8
3.1 Symbols.....	8
3.2 Abbreviations	8
4 Configurations.....	9
4.1 Reference configuration	9
4.1.1 Basic configuration	9
4.1.2 Portable Part (PP)	11
4.1.2.1 Functional organization.....	11
4.1.2.2 Volume control	11
4.1.3 Fixed Part (FP).....	12
4.1.3.1 Digital interface.....	12
4.1.3.2 Analogue interface	12
4.1.3.3 FP adaptive volume control	13
4.2 Test configurations	13
5 Encoding.....	13
5.1 32 kbit/s full term (ADPCM)	13
5.1.1 Algorithm.....	13
5.1.2 Bit sequence.....	13
5.2 Other codings	13
6 Transmission aspects.....	14
6.1 Relative level.....	14
6.2 Acoustic reference level	14
6.3 Volume control.....	14
7 Speech performance characteristics	14
7.1 PP frequency responses	14
7.1.1 Sending	14
7.1.2 Receiving	15
7.2 PP sending and receiving loudness ratings.....	15
7.2.1 Nominal values	15
7.2.2 User-controlled volume control in PP.....	15
7.2.3 PP adaptive volume control	16
7.2.4 FP adaptive volume control	16
7.3 Sidetone.....	16
7.3.1 Talker sidetone.....	16
7.3.2 Listener sidetone	17
7.4 Terminal coupling loss	17
7.4.1 Weighted Terminal Coupling Loss (TCLw).....	17
7.4.1.1 PP for the 3,1 kHz service (PSTN or ISDN).....	17
7.4.1.2 FP with 4-wire interface.....	17
7.4.1.3 FP with analogue 2-wire interface	18
7.4.1.4 PP for unrestricted 64 kbit/s service.....	18
7.4.2 Stability loss.....	18
7.4.2.1 Requirement	18
7.4.2.2 Test conditions	18
7.4.2.3 Fixed geometry PP	18
7.4.2.4 Variable geometry PP	19
7.5 Distortion.....	19
7.5.1 Sending	19

iTeh STANDARD PREVIEW
(standards.iteh.ai)

SIST EN 300 175-8 V1.9.1:2006

<https://standards.iteh.ai/catalog/standards/sist/d740ec23-f32f-4ca6-bcaf-a33623f2aeb0/sist-en-300-175-8-v1-9-1-2006>

7.5.2	Receiving	19
7.5.3	Sidetone	19
7.5.4	Equipment Impairment value for end-to-end transmission planning	19
7.6	Out of band signals	19
7.6.1	Sending (discrimination against out of band input signals)	19
7.6.2	Receiving (spurious out of band signals)	20
7.7	Noise	20
7.7.1	Sending	20
7.7.2	Narrow-band noise	20
7.7.3	Receiving	20
7.7.4	Level of sampling frequency (receiving)	20
7.8	Acoustic shock	20
7.8.1	Continuous signal	20
7.8.2	Peak signal	20
7.9	Delay	21
7.9.1	DECT network	21
7.9.2	PP	21
7.9.3	FP	21
7.10	Network echo control	21
7.11	PP ambient noise rejection	22
7.12	Additional requirements for DECT systems provided with a 2-wire PSTN interface	22
7.12.1	General	22
7.12.1.1	Polarity independence	22
7.12.1.2	Feed Conditions	22
7.12.1.3	Power supply	22
7.12.2	Speech performance characteristics	22
7.12.2.1	Sensitivity/frequency response	23
7.12.2.2	Sending and Receiving Loudness Ratings (SLR and RLR)	23
7.12.2.3	Distortion	23
7.12.2.4	Noise	23
7.12.2.5	Echo Return Loss	23
8	Additional features	23
8.1	Loudspeaking and hand-free facilities	23
8.2	Tandem with mobile radio network	23
8.2.1	Tandem with GSM	24
8.2.1.1	Network echo control	24
8.2.1.2	Terminal coupling loss	24
8.2.1.3	The GSM mobile transmitter operates in continuous mode	24
8.2.1.4	The GSM mobile transmitter operates in discontinuous mode, DTX	24
8.3	DECT connected to the GSM fixed network	24
8.3.1	Network echo control	25
8.3.2	Terminal coupling loss	25
8.4	Wireless Relay Stations (WRS)	25
8.4.1	Modified FP network echo control requirements for implementation of 2 and 3 CRFP links in cascade	26
Annex A (informative): Description of "reference" echo control devices		27
A.1	Handset echo	27
A.1.1	Overview	27
A.1.1.1	Connection to the PSTN/ISDN	27
A.1.1.1.1	Local and national calls	27
A.1.1.1.2	Long distance connections with echo control devices in the PSTN/ISDN, e.g. calls via satellites	27
A.1.1.2	Connection to the GSM network	28
A.1.2	Implementation of the FP echo control function	28
A.1.2.1	Suppression threshold	29
A.1.2.2	Static characteristics of activation control	29
A.1.2.3	Dynamic characteristics of activation control	29
A.2	Network echo	29
A.2.1	Soft suppressor implementation of requirement 2	30
A.2.1.1	Static characteristics	31

A.2.1.2	Dynamic characteristics	31
A.2.2	Additional echo control for a 2-wire interface of requirement 1	31
A.2.3	Echo canceller used for both requirements 1 and 2	32
Annex B (informative):	Local loop application	33
B.1	DECT tethered local loop replacement with 2-wire PP end system.....	33
B.1.1	TCLw requirements.....	33
B.1.2	Network echo	34
Annex C (informative):	GSM Discontinuous Transmission (DTX), and Voice Activity Detection (VAD).....	35
Annex D (informative):	Speech levels in relation to ambient room noise and examples of adaptive volume control settings	36
Annex E (informative):	Bibliography.....	37
Annex F (informative):	Change history	38
History		39

iTeh STANDARD PREVIEW (standards.iteh.ai)

[SIST EN 300 175-8 V1.9.1:2006](https://standards.iteh.ai/catalog/standards/sist/d740ec23-f32f-4ca6-bcaf-a33623f4aeb0/sist-en-300-175-8-v1-9-1-2006)

<https://standards.iteh.ai/catalog/standards/sist/d740ec23-f32f-4ca6-bcaf-a33623f4aeb0/sist-en-300-175-8-v1-9-1-2006>

Intellectual Property Rights

IPRs essential or potentially essential to the present document may have been declared to ETSI. The information pertaining to these essential IPRs, if any, is publicly available for **ETSI members and non-members**, and can be found in ETSI SR 000 314: "*Intellectual Property Rights (IPRs); Essential, or potentially Essential, IPRs notified to ETSI in respect of ETSI standards*", which is available from the ETSI Secretariat. Latest updates are available on the ETSI Web server (<http://webapp.etsi.org/IPR/home.asp>).

Pursuant to the ETSI IPR Policy, no investigation, including IPR searches, has been carried out by ETSI. No guarantee can be given as to the existence of other IPRs not referenced in ETSI SR 000 314 (or the updates on the ETSI Web server) which are, or may be, or may become, essential to the present document.

Foreword

This European Standard (Telecommunications series) has been produced by ETSI Project Digital Enhanced Cordless Telecommunications (DECT).

The present document is part 8 of a multi-part deliverable. Full details of the entire series can be found in part 1 [1].

Further details of the DECT system may be found in TR 101 178 and ETR 043 (see bibliography).

National transposition dates	
Date of adoption of this EN:	26 August 2005
Date of latest announcement of this EN (doa):	30 November 2005
Date of latest publication of new National Standard or endorsement of this EN (dop/e):	31 May 2006
Date of withdrawal of any conflicting National Standard (dow):	31 May 2006

1 Scope

The present document gives an introduction and overview of the complete Digital Enhanced Cordless Telecommunications (DECT) Common Interface (CI).

This part of the DECT CI specifies the speech coding and transmission requirements.

In order to ensure satisfactory interworking of different portable and fixed units, it is necessary to specify the transmission performance of the analogue information over the digital link. This requires not only use of a common speech algorithm, but also standardization of frequency responses, reference speech levels (or loudness) at the air interface and various other parameters.

The present document applies to DECT equipment which includes all the necessary functions to provide real-time two-way speech conversation. A 3,1 kHz telephony teleservice conveyed over a DECT link (including Fixed Part (FP) and Portable Part (PP)) which is capable of being connected (directly or indirectly) to the public network access point should comply with the requirements in the present document.

Tethered fixed point local loop applications are not required to comply with the requirements of the present document.

The speech performance characteristics defined in the present document typically conform to TBR 008 (see bibliography), which specifies the overall performance between the handset acoustic interface and a 64 kbit/s A-law Pulse Code Modulated (PCM) digital network interface. The deviations from TBR 008 are mainly due to the consequences of non-PCM coding and transmission delay.

The additional features described in clause 8 are those which are not included in TBR 008, but which are likely to occur in a DECT system: analogue interface, loudspeaking and hand-free facilities, tandeming with a mobile radio network. Headsets are not covered by the present specifications.

For the DECT systems which connect to the Public Switched Telephone Network (PSTN) via an analogue interface, the additional requirements, which are implemented in the FP, have as much as possible been aligned with TBR 038 (see bibliography).

A summary of the control and the use of the DECT echo control functions, to guide on need for options to manufacturers and installers, is found in annex A.

Information concerning test methods can be found in EN 300 176 [3]. The test methods take into account that DECT is a digital system.

2 References

The following documents contain provisions which, through reference in this text, constitute provisions of the present document.

- References are either specific (identified by date of publication and/or edition number or version number) or non-specific.
- For a specific reference, subsequent revisions do not apply.
- For a non-specific reference, the latest version applies.

Referenced documents which are not found to be publicly available in the expected location might be found at <http://docbox.etsi.org/Reference>.

- [1] ETSI EN 300 175-1: "Digital Enhanced Cordless Telecommunications (DECT); Common Interface (CI); Part 1: Overview".
- [2] ETSI EN 300 175-5: "Digital Enhanced Cordless Telecommunications (DECT); Common Interface (CI); Part 5: Network (NWK) layer".
- [3] ETSI EN 300 176 (all parts): "Digital Enhanced Cordless Telecommunications (DECT); Test specification; (Part 1: Radio; Part 2: Speech)".

- [4] Void.
- [5] Void.
- [6] Void.
- [7] Void.
- [8] ITU-T Recommendation G.701: "Vocabulary of digital transmission and multiplexing, and pulse code modulation (PCM) terms".
- [9] ITU-T Recommendation G.726: "40, 32, 24, 16 kbit/s Adaptive Differential Pulse Code Modulation (ADPCM)".
- [10] Void.
- [11] ITU-T Recommendation P.10: "Vocabulary of terms on telephone transmission quality and telephone sets".
- [12] ITU-T Recommendation P.340: "Transmission characteristics and speech quality parameters of hands-free terminals".
- [13] Void.
- [14] ITU-T Recommendation G.111: "Loudness Ratings (LRs) in an international connection".
- [15] ETSI ETS 300 540: "Digital cellular telecommunications system (Phase 2) (GSM); Transmission planning aspects of the speech service in the GSM Public Land Mobile Network (PLMN) system (GSM 03.50)".

STANDARD PREVIEW

(standards.iteh.ai)

3 Symbols and abbreviations

SIST EN 300 175-8 V1.9.1:2006

3.1 Symbols

<https://standards.iteh.ai/catalog/standards/sist/d740ec23-f32f-4ca6-bcaf-a33623f4aeb0/sist-en-300-175-8-v1-9-1-2006>

For the purposes of the present document, the symbols given in ITU-T Recommendations P.10 [11], G.701 [8], EN 300 175-1 [1] and the following apply:

dBm: absolute power level relative to 1 milliwatt, expressed in dB

dBm0: absolute power level in dBm referred to a point of zero relative level (0 dBr point)

dBPa: sound pressure level relative to 1 Pa, expressed in dB

dBPa(A): a-weighted sound pressure level relative to 1 Pa, expressed in dB

dBr: relative power level of a signal in a transmission path referred to the level at a reference point on the path (0 dBr point)

3.2 Abbreviations

For the purposes of the present document, the abbreviations given in ITU-T Recommendations P.10 [11], G.701 [8] and the following apply:

ADPCM	Adaptive Differential Pulse Code Modulation
BSS	Base Station Sub-system
CI	Common Interface
CLRR	Circuit Loudness Rating, Receiving
CLRS	Circuit Loudness Rating, Sending
CRFP	Cordless Radio Fixed Part
DECT	Digital Enhanced Cordless Telecommunications
DTX	Discontinuous Transmission

ERP	Ear Reference Point
ES	End System
EUT	Equipment Under Test
FP	Fixed Part
FT	Fixed radio Termination
GAP	Generic Access Profile
GSM	Global System for Mobile communications
IC	Integrated Circuit
I _e	equipment Impairment factor
ISDN	Integrated Services Digital Network
LL _e	Local echo Loss
LSTR	Listener SideTone Rating
MRP	Mouth Reference Point
MSC	Mobile Switching Centre
NLP	Non-Linear Processor
NWK	NetWorK
PABX	Private (Automatic) Branch eXchange
PCM	Pulse Code Modulated
PP	Portable Part
PSTN	Public Switched Telephone Network
PT	Portable radio Termination
REP	REpeater Part
RePP	Reference Portable Part
RF	Radio Frequency
RFP	Radio Fixed Part
RLR	Receiving Loudness Rating
RLR _H	Receiving Loudness Rating of the Handset
SLR	Sending Loudness Rating
SLR _H	Sending Loudness Rating of the Handset
STMR	SideTone Masking Rating
TA	Terminal Adaptors
TCLw	weighted Terminal Coupling Loss
TDMA	Time Division Multiple Access
TELr	Talker's Echo Loudness Rating
VAD	Voice Activity Detection
WBS	Wireless Base Station
WRS	Wireless Relay Station

4 Configurations

4.1 Reference configuration

4.1.1 Basic configuration

The basic reference configuration for voice transmission over DECT is shown in figure 1.

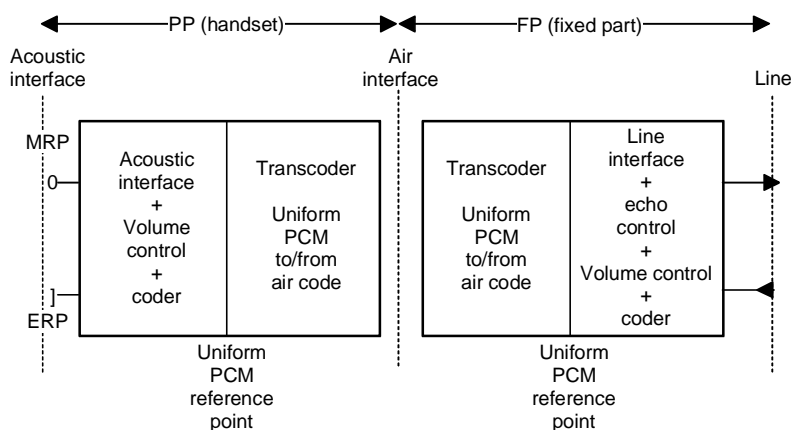

Figure 1: Basic reference configuration

The PP and the FP are delimited by physical interfaces:

- Acoustic: from the PP towards the speaker-listener, with the Ear and Mouth Reference Points (ERP and MRP).
- Air(RF): the interface between PP and FP.
- Line: the interface from the FP towards the network.

Uniform PCM reference points shall be introduced in both the PP and the FP to materialize the limits of the transmission segment which is affected by the air interface coding scheme. This allows the transmission requirements to be specified independently from the coding at the air interface. The various transcoding algorithms are level-transparent, i.e. with an encoder and decoder connected in tandem, the "levels" of the digital signals at the uniform PCM input of the encoder and output from the decoder are identical. In a particular implementation, the reference points may be embedded within an IC, and thus will not be physically accessible.

Each of the three sections thus delimited deals with distinct functions:

- a) the PP electro-acoustic section (between acoustic interface and PP uniform PCM reference point) which includes the acoustic interface, the volume control and the analogue to digital conversion;
- b) the air-code section (between PP and FP uniform PCM reference points) considers the transcoding between uniform PCM and the air-code, as well as the transmission over the air interface;
- c) the FP line interface section (between FP uniform PCM reference point and line interface) comprises the interface to the line, digital or analogue, and the FP voice processing, e.g. echo control.

Typically, the transmission features conform to TBR 008 (see bibliography) for the PP electro-acoustic section, and the line interface section in the case of digital interface. In the case of analogue interface, the line interface section realizes in the FP the adaptation to clause 7.12 and to the relevant attachment requirements.

4.1.2 Portable Part (PP)

4.1.2.1 Functional organization

Figure 2 represents the basic functional organization of a PP from the voice transmission point of view.

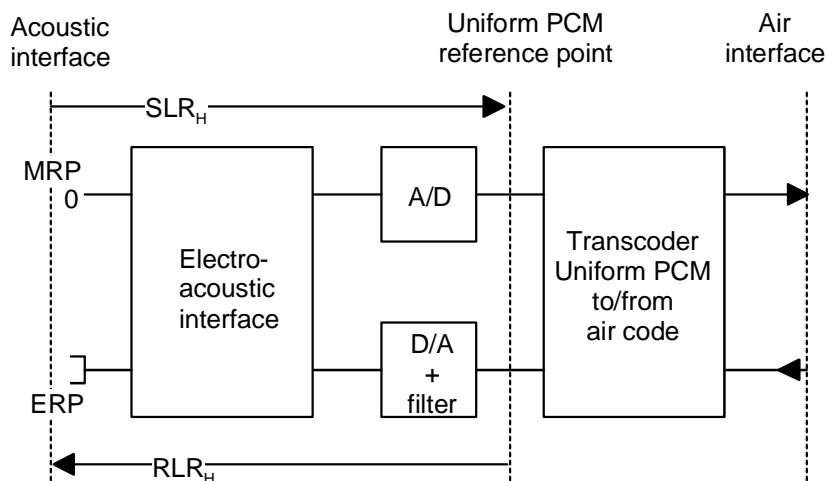

Figure 2: PP functional organization

The various functions represented in figure 2 are:

- the electro-acoustic function, which performs the interface to the transducers and the volume control. The Handset Loudness Ratings (SLR_H) and (RLR_H) are defined between the acoustic interface and the uniform PCM reference point;
- the analogue to digital and digital to analogue coding to the uniform PCM reference point;
- the transcoder between uniform PCM and air-code.

4.1.2.2 Volume control

The volume control facility is optional, and can be implemented in a number of different ways:

- in the simplest implementation, it affects only the receiving level and is under the manual control of the PP user;
- the volume adjustment may also be adaptive, e.g. taking into account the average level of ambient noise at the MRP;
- the volume control may affect both receiving and sending levels in opposite directions. This has the advantage of reducing the influence on the terminal coupling loss when the receive volume is increased. Such an implementation would fit a noisy environment, as the need for an increased receiving volume is likely to come from a loud ambient noise, and it is then combined with a loud speech level.