



Standard Test Method for Determining Durability of Adhesive Joints Stressed in Shear by Tension Loading¹

This standard is issued under the fixed designation D 2919; the number immediately following the designation indicates the year of original adoption or, in the case of revision, the year of last revision. A number in parentheses indicates the year of last reapproval. A superscript epsilon (ϵ) indicates an editorial change since the last revision or reapproval.

This standard has been approved for use by agencies of the Department of Defense.

1. Scope

1.1 This test method provides data for assessing the durability of adhesive lap-shear joints while stressed in contact with air, air in equilibrium with certain solutions, water, aqueous solutions, or other environments at various temperatures.

1.2 *This standard does not purport to address all of the safety concerns, if any, associated with its use. It is the responsibility of the user of this standard to establish appropriate safety and health practices and determine the applicability of regulatory limitations prior to use.* Specific precautionary statements are given in 7.4.

1.3 The values stated in SI units are considered to be the standard. The values in parentheses are for information only.

2. Referenced Documents

2.1 ASTM Standards:

D 907 Terminology of Adhesives²

D 1002 Test Method for Apparent Shear Strength of Single-Lap-Joint Adhesively Bonded Metal Specimens by Tension Loading (Metal-to-Metal)²

D 1828 Practice for Atmospheric Exposure of Adhesively Bonded Joints and Structures²

D 2294 Test Method for Creep Properties of Adhesives in Shear by Tension Loading (Metal-to-Metal)²

D 3165 Test Method for Strength Properties of Adhesives in Shear by Tension Loading of Single-Lap-Joint Laminated Assemblies²

3. Terminology

3.1 *Definitions*—Definitions of terms in this test method may be found in Terminology D 907.

4. Significance and Use

4.1 The combination of stress and moisture decreases the durability of most adhesive joints. Stresses in the presence of water or water vapor may cause some adhesive joints to fail at some small fraction of the stress required to break the dry joint.

¹ This test method is under the jurisdiction of ASTM Committee D14 on Adhesives and is the direct responsibility of Subcommittee D14.80 on Metal Bonding Adhesives.

Current edition approved Nov. 10, 2000. Published January 2001. Originally published as D 2919 – 71. Last previous edition D 2919 – 95.

² *Annual Book of ASTM Standards*, Vol 15.06.

The time to failure for a given adhesive joint generally decreases with increasing stress, temperature, and relative humidity.

4.2 This test method may be used as an accelerated screening test for assessing the durability of adhesive joints. It may be used to measure durability of adhesive joints exposed outdoors or to environmental conditions experienced by adhesive joints in service. The tests may also be used to determine the effects of various surface preparations or substrates on durabilities of adhesive joints.

4.3 The durability performance of various adhesives may be compared by using this test method under uniform sets of conditions. To assess the overall durability of a given adhesive, lap-shear joints should be tested under a range of stress, relative humidity, and temperature. For a specific end use it may be possible to obtain the needed durability data using only one set of test conditions.

5. Apparatus

5.1 *Fixture*, as shown in Fig. 1,³ is required for this test method, although a fixture such as described in Test Method D 2294 may also be suitable for the performance of this test.

5.2 *Testing Machine*, or other suitable machine capable of applying measured compressive loads, equipped with a suitable loading base as shown in Fig. 1, shall be used as a loading mechanism.

5.3 *Outdoor Weathering Racks (Standard)* are recommended (Practice D 1828), but any stable frame may be used (for example, galvanized pipe or painted steel channel). No other special apparatus is required for outdoor tests.

6. Test Specimens

6.1 The successful use of this test method depends on preparing good quality lap-shear joints. The test joints must be prepared carefully in accordance with the adhesive manufacturer's directions or in accordance with some other specified set of conditions agreed upon between the manufacturer and the purchaser. It is recommended that the test joints be prepared in accordance with Test Method D 1002, except that

³ Detailed working drawings for the construction of the durability test apparatus are available from ASTM Headquarters. Request Adjunct No. ADJD2919.

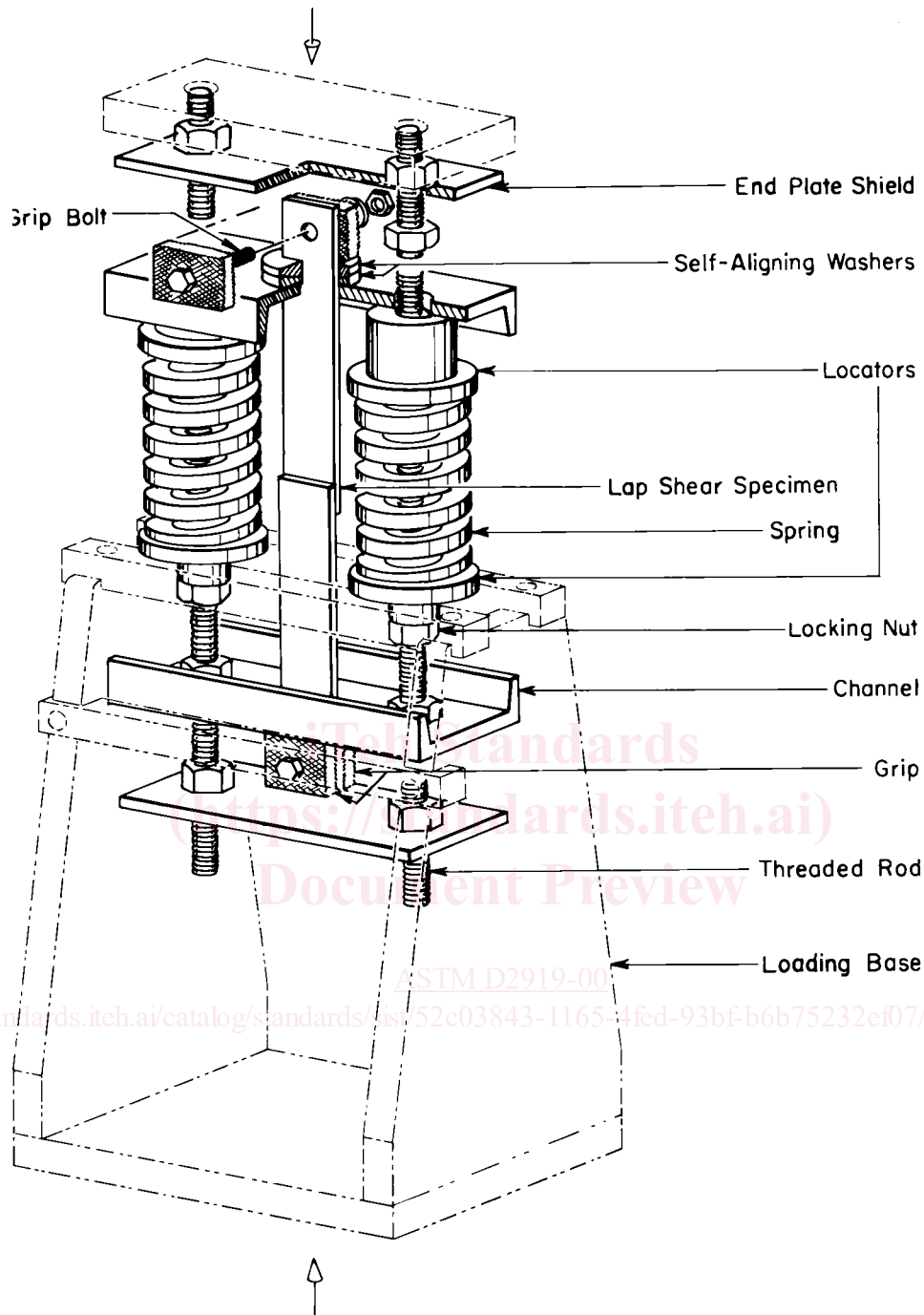

FIG. 1 Durability Test Apparatus

the dimensions of the test specimens shall be as shown in Fig. 2.

6.2 If the fixture in Fig. 1 is used, test specimens of the dimensions shown in Fig. 2 must be used. If the fixture described in Test Method D 2294 is used, the test specimen described in that test method must be used.

6.3 If it is desired to use test specimens of thickness or overlap different from that recommended in this test method or in Test Method D 2294, the guidelines set forth in Note 2 and Note 3 of Test Method D 1002, regarding permissible test specimen dimensions with respect to thickness and overlap, shall be followed. Test specimen size, of course, must always

be compatible with the appropriate fixture.

6.4 An alternative test specimen may be used in accordance with Test Method D 3165 with the exception that the lengthwise dimension must be compatible with the test specimen shown in Fig. 2.

7. Procedure

7.1 Test six specimens to destruction at $23.0 \pm 1^\circ\text{C}$ ($73.4 \pm 1.8^\circ\text{F}$) and $50 \pm 2\%$ relative humidity in accordance with Test Method D 1002, after conditioning in this environment for not less than 40 h, unless otherwise specified. Compute and record