

INTERNATIONAL
STANDARD

ISO
11339

First edition
1993-08-15

**Adhesives — 180° peel test for
flexible-to-flexible bonded assemblies
(T-peel test)**

iTeh STANDARD PREVIEW

*Adhésifs — Essai de pelage à 180° d'assemblages collés
flexible-sur-flexible (essai de pelage en T)*

ISO 11339:1993

<https://standards.itih.ai/catalog/standards/sist/dfd55107-6411-4af8-818c-3ac36a216ae5/iso-11339-1993>



Reference number
ISO 11339:1993(E)

Foreword

ISO (the International Organization for Standardization) is a worldwide federation of national standards bodies (ISO member bodies). The work of preparing International Standards is normally carried out through ISO technical committees. Each member body interested in a subject for which a technical committee has been established has the right to be represented on that committee. International organizations, governmental and non-governmental, in liaison with ISO, also take part in the work. ISO collaborates closely with the International Electrotechnical Commission (IEC) on all matters of electrotechnical standardization.

Draft International Standards adopted by the technical committees are circulated to the member bodies for voting. Publication as an International Standard requires approval by at least 75 % of the member bodies casting a vote.

International Standard ISO 11339 was prepared by Technical Committee ISO/TC 61, *Plastics*, Sub-Committee SC 11, *Products*.

[ISO 11339:1993](https://standards.iteh.ai/catalog/standards/sist/dfd55107-6411-4af8-818c-3ac36a216ae5/iso-11339-1993)

<https://standards.iteh.ai/catalog/standards/sist/dfd55107-6411-4af8-818c-3ac36a216ae5/iso-11339-1993>

© ISO 1993

All rights reserved. No part of this publication may be reproduced or utilized in any form or by any means, electronic or mechanical, including photocopying and microfilm, without permission in writing from the publisher.

International Organization for Standardization
Case Postale 56 • CH-1211 Genève 20 • Switzerland

Printed in Switzerland

Adhesives — 180° peel test for flexible-to-flexible bonded assemblies (T-peel test)

1 Scope

This International Standard specifies a 180° peel test for the determination of the peel strength of an adhesive by measuring the peeling force of a T-shaped bonded assembly of two flexible adherends.

NOTE 1 This method was originally developed for use with metal adherends, but other flexible adherends may also be used.

2 Normative references

The following standards contain provisions which, through reference in this text, constitute provisions of this International Standard. At the time of publication, the editions indicated were valid. All standards are subject to revision, and parties to agreements based on this International Standard are encouraged to investigate the possibility of applying the most recent editions of the standards indicated below. Members of IEC and ISO maintain registers of currently valid International Standards.

ISO 291:1977, *Plastics — Standard atmospheres for conditioning and testing*.

ISO 472:1988, *Plastics — Vocabulary*.

ISO 4588:1989, *Adhesives — Preparation of metal surfaces for adhesive bonding*.

ISO 10365:1992, *Adhesives — Designation of main failure patterns*.

3 Definitions

For the purposes of this International Standard, the definitions given in ISO 472 and the following definitions apply.

3.1 peel strength: Force per unit width necessary to bring an adhesive joint to the point of failure and/or maintain a specified rate of failure by means of a stress applied in a peeling mode. [ISO 472]

3.2 flexible adherends: Adherends having dimensions and physical properties that permit bending through any angle up to 90° without breaking or cracking.

4 Principle

For the 180° T-peel test for a flexible-to-flexible assembly, the force is applied to the unbonded ends of the specimen. The angle between the bond line and the direction of the applied force is not fixed.

Adherends are separated at an approximately steady rate from an open edge of a prepared bond, so that separation occurs progressively along the bond line.

5 Apparatus

5.1 Tensile testing machine¹⁾, capable of maintaining a predetermined constant crosshead rate (preferred rate 100 mm/min). It shall be provided with a suitable self-aligning grip to hold the specimen. Each set of jaws of the grip shall firmly engage the outer 25 mm of one of the unbonded ends of the flexible adherend. The grip and attachments shall be constructed in such a way that they will move into alignment with the specimen as soon as the force is applied. The machine shall produce a chart that can be read in terms of millimetres of crosshead movement as a function of the applied force.

The machine shall permit the measurement and recording of the applied force with an accuracy of $\pm 2\%$. All equipment shall be calibrated regularly. It is recommended that inertia-free equipment be used for this test.

1) See for instance ISO 5893:—, *Rubber and plastics test equipment — Tensile, flexural and compression types (constant rate of traverse) — Description*.

5.2 Device for measuring thickness, with an accuracy of $\pm 0,01$ mm or a means of controlling the thickness to that tolerance.

6 Test specimens

6.1 Test specimens of the dimensions shown in figure 1 shall be prepared, either individually or cut from bonded laminates. Individual test specimens shall consist of two flexible adherends properly prepared and bonded together.

6.2 Surface treatment shall be such as to obtain optimum strength in the bonded assembly. The preparation of the surface shall be in accordance with either the adhesive manufacturer's instructions or ISO 4588 in the case of metal substrates, and the preparation shall be stated in the test report.

The adhesive shall be applied in accordance with the manufacturer's instructions to obtain an optimum bond with minimum variation; the procedure shall be reported in the test report.

NOTE 2 Direct comparison of different adhesives can be made only when specimen construction, adherend materials and dimensions, and test conditions are identical.

6.3 The thickness of the flexible adherends shall be reported.

NOTE 3 The preferred thicknesses are 0,5 mm $\pm 0,02$ mm for steel and 0,5 mm $\pm 0,02$ mm or 0,7 mm $\pm 0,02$ mm for aluminium unless otherwise specified.

6.4 Test specimens shall be cut from the bonded panels (see figure 1) by a method that is not deleterious to the bond.

The width shall be either

a) 25 mm (preferred width)

or

b) any other convenient width, provided that the test equipment is suitably adapted and the width is stated in the test report.

NOTE 4 The method of cutting the specimens is dependent upon the adherend and adhesive compositions and the specimen width tolerance specified in figure 1. Circular sawing and bandsawing are two methods commonly used for this purpose.

6.5 The two unbonded ends of the flexible adherends shall be bent in opposite directions until each end is perpendicular to the bonded assembly, to form a T-shaped specimen (see figure 1) for clamping in the grips of the testing machine.

6.6 The number of specimens tested shall be not less than five.

6.7 The specimens shall be conditioned and tested in one of the standard laboratory atmospheres specified in ISO 291, which shall be reported in the test report.

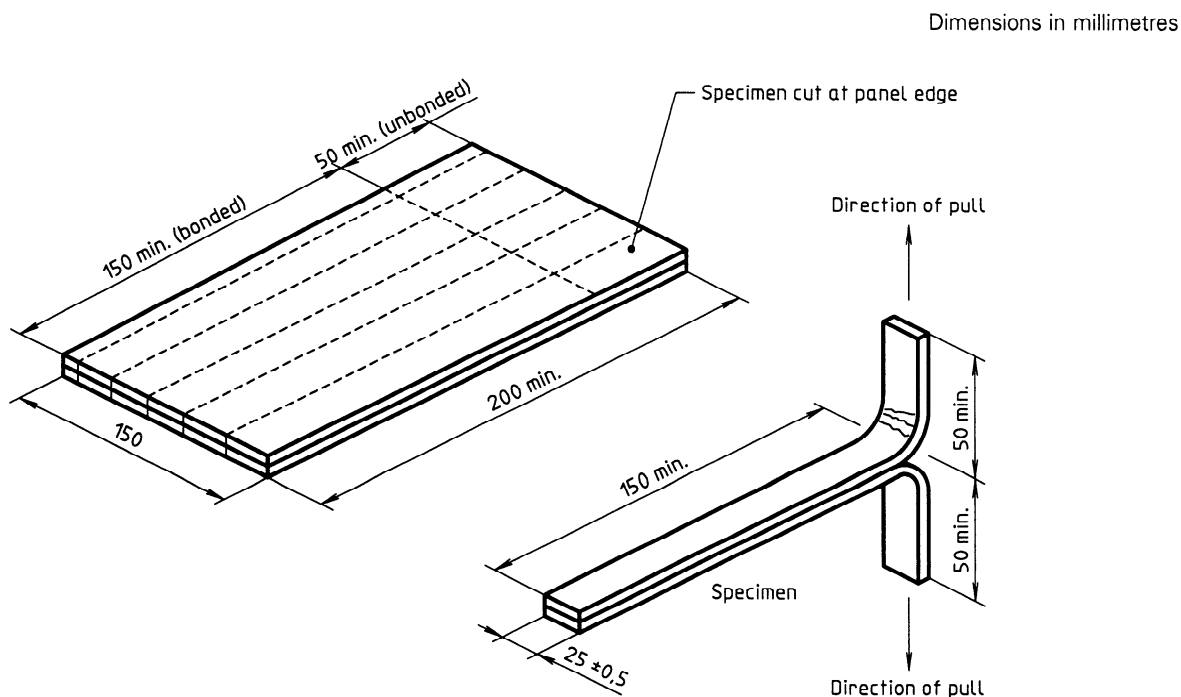

Figure 1 — Panel before cutting and individual specimen after cutting

7 Test procedure

On at least five specimens, using the device described in 5.2, measure with an accuracy of $\pm 0,01$ mm the average thickness of the adhesive layer after formation of the bond.

Clamp each unbonded end of the T-shaped specimen in the grips of the testing machine, taking care that the end is accurately aligned between the grips, so that the tension applied is distributed evenly across the width. If one adherend is more flexible than the other, attach the less flexible adherend to the moveable grip.

Set the machine in motion at the selected separation rate, and record the force applied versus the distance of grip separation.

NOTE 5 A separation rate of 100 mm/min is generally used for metals and 10 mm/min for other adherends.

Continue the test until at least 150 mm of the bonded length is separated. Note the type of failure according to ISO 10365.

8 Expression of results

Determine from the recorded curve, for at least 100 mm of peeling (disregarding the first 25 mm and the last 25 mm), the average peeling force, in kilonewtons, required to separate the adherends. The average force shall be determined from the graph by drawing the best straight line, or by using other suitable means if a more accurate result is required.

Record the average, maximum and minimum peeling forces for each individual specimen.

9 Precision

The precision of this test method is not known because interlaboratory data are not available. When interlaboratory data are obtained, a precision statement will be added at the time of revision.

10 Test report

The test report shall include the following particulars:

- a) reference to this International Standard;
- b) all information necessary for complete identification of the adhesive tested, including type, source, manufacturer's code number, batch or lot number, form, etc.;
- c) all information necessary for complete identification of adherends, including the nature and the thickness of the material, width and surface preparation;
- d) description of the bonding process, including method of application of adhesive, drying or pre-curing conditions (where applicable), curing time, temperature and pressure;
- e) average thickness of the adhesive layer after formation of the bond;
- f) complete description of the specimen, whether individual or cut from panel, including dimensions and construction of the specimen, conditions used for cutting individual specimen, number of test panels represented and number of individual specimens (when edge specimens are tested they shall be designated "edge specimens");
- g) conditioning procedure prior to testing and the test atmosphere;
- h) crosshead separation rate;
- i) method of determining the average peeling force;
- j) average, maximum and minimum peeling force values, in kilonewtons, for each individual specimen (edge samples shall be reported separately);
- k) calculated average, maximum and minimum peel strength values, in kilonewtons per metre of specimen width, for each specimen (edge samples shall be reported separately);
- l) pattern of failure according to ISO 10365.

iTeh STANDARD PREVIEW
(standards.iteh.ai)

ISO 11339:1993

<https://standards.iteh.ai/catalog/standards/sis/11339-1993>

iTeh STANDARD PREVIEW
(standards.iteh.ai)

This page intentionally left blank

ISO 11339:1993

<https://standards.iteh.ai/catalog/standards/sist/dfd55107-6411-4af8-818c-3ac36a216ae5/iso-11339-1993>

iTeh STANDARD PREVIEW
(standards.iteh.ai)

This page intentionally left blank

ISO 11339:1993

<https://standards.iteh.ai/catalog/standards/sist/dfd55107-6411-4af8-818c-3ac36a216ae5/iso-11339-1993>

iTeh STANDARD PREVIEW
(standards.iteh.ai)

ISO 11339:1993

<https://standards.iteh.ai/catalog/standards/sist/dfd55107-6411-4af8-818c-3ac36a216ae5/iso-11339-1993>

UDC 665.93:620.179.4

Descriptors: plastics, adhesives, metals, adhesive bonded joints, tests, adhesion tests, peel tests.

Price based on 3 pages
