



Designation: D5148 – 97 (Reapproved 2002)

Standard Test Method for Centrifuge Kerosine Equivalent¹

This standard is issued under the fixed designation D5148; the number immediately following the designation indicates the year of original adoption or, in the case of revision, the year of last revision. A number in parentheses indicates the year of last reapproval. A superscript epsilon (ϵ) indicates an editorial change since the last revision or reapproval.

1. Scope

1.1 This test method determines the centrifuge kerosine equivalent (CKE) of aggregate used in bituminous mixtures.

1.2 Units of Measure:

1.2.1 With regard to sieve sizes and size of aggregate as determined by the use of testing sieves, the values in inch-pound units are shown for the convenience of the user, but the standard sieve designation shown in parentheses is the standard value as stated in Specification E11.

1.2.2 With regard to other units of measure, the values shown in parentheses are for information purposes.

1.3 This standard does not purport to address all of the safety concerns, if any, associated with its use. It is the responsibility of the user of this standard to establish appropriate safety and health practices and determine the applicability of regulatory limitations prior to use. For specific hazard statements, see 7.1.

2. Referenced Documents

2.1 ASTM Standards:²

C127 Test Method for Density, Relative Density (Specific Gravity), and Absorption of Coarse Aggregate

C128 Test Method for Density, Relative Density (Specific Gravity), and Absorption of Fine Aggregate

C702 Practice for Reducing Samples of Aggregate to Testing Size

D75 Practice for Sampling Aggregates

D4753 Guide for Evaluating, Selecting, and Specifying Balances and Standard Masses for Use in Soil, Rock, and Construction Materials Testing

E11 Specification for Woven Wire Test Sieve Cloth and Test Sieves

E832 Specification for Laboratory Filter Papers

¹ This test method is under the jurisdiction of ASTM Committee D04 on Road and Paving Materials and is the direct responsibility of Subcommittee D04.51 on Aggregate Tests.

Current edition approved July 10, 2002. Published February 1998. Originally published as D5148 – 90. Last previous edition D5148 – 95. DOI: 10.1520/D5148-97R02.

² For referenced ASTM standards, visit the ASTM website, www.astm.org, or contact ASTM Customer Service at service@astm.org. For Annual Book of ASTM Standards volume information, refer to the standard's Document Summary page on the ASTM website.

3. Terminology

3.1 Symbols:

3.1.1 C —coarse aggregate fraction, that portion of the sample which passes the $\frac{3}{8}$ -in. (9.5-mm) sieve and is retained on the No. 4 (4.75-mm) sieve.

3.1.2 F —fine aggregate fraction, that portion of the sample which passes the No. 4 (4.75-mm) sieve.

3.1.3 SA —surface area. The sum, m^2/kg (ft^2/lb), obtained by adding the products of the percent passing each sieve and its corresponding factor, (see 11.1) and dividing by 100.

3.1.4 K factors—values determined as described in 3.1.5 through 3.1.8 and identified as K_c , K_f , or K_m .

3.1.5 K_c —determined from the percent of SAE No. 10 oil retained, which represents the total effect of the aggregate's absorptive properties and surface roughness of the aggregates coarse fraction.

NOTE 1—Based on comparative testing in California, the same results can be obtained substituting Shell Tellus No. 100 oil for SAE No. 10 oil.

3.1.6 K_f —determined from the following factors:

3.1.7 Percent of kerosine retained, which represents the total effect of superficial area, the aggregate's absorptive properties and surface roughness of the aggregate's fine fraction.

3.1.7.1 Computed surface area, based on particle size.

3.1.7.2 Percent of aggregate passing No. 4 (4.75-mm) sieve.

3.1.8 K_m —the “mean” or composite value of K for a given combination of coarse and fine materials on which K_c and K_f have already been determined independently.

4. Significance and Use

4.1 The CKE furnishes an index, designated as the K factor, that indicates the aggregate particle roughness and surface capacity based on porosity.

4.2 The CKE is used as part of the Hveem mix design procedure to determine the approximate bitumen ratio (ABR), as shown in Appendix X1. However, there are other applications such as determining the coarse aggregate fraction constant (K_c) for use as an aid in selecting a bitumen content for open-graded friction courses.

5. Apparatus

5.1 *Centrifuge*, power driven, capable of exerting a force of 400 ± 8 times gravity (400 G) on a 100-g sample.

The required r/min (± 10) of the centrifuge head =
 $\sqrt{(25.4(14\ 000\ 000/r))}$

where r = radius to center of gravity of sample, mm.

5.2 *Centrifuge Cups*, 71.4 ± 1.6 mm ($2\frac{3}{16} \pm \frac{1}{16}$ in.) in height and 52.4 ± 1.6 mm ($2\frac{1}{16} \pm \frac{1}{16}$ in.) inside diameter (see Fig. 1) complete with perforated brass plate 0.787 ± 0.03 mm (0.031 ± 0.001 in.) thick with a minimum of 15 holes, 1.575 mm ± 0.03 mm (0.062 ± 0.001 in.) in diameter, per square centimetre (100 holes/in.²).

5.3 *Balance*—A balance having a minimum capacity of 500 g and meeting the requirements of Specification D4753, Class GP2.

5.4 *Metal Funnel*, top diameter 98.4 ± 1.6 mm ($3\frac{7}{8} \pm \frac{1}{16}$ in.), height 109.5 ± 1.6 mm ($4\frac{5}{16} \pm \frac{1}{16}$ in.), orifice 12.7 ± 1.6 mm ($\frac{1}{2} \pm \frac{1}{16}$ in.), with a piece of No. 10 (2.0-mm) sieve soldered slightly above the orifice (Fig. 2).

5.5 *Tin Pan*, round, 114.3 ± 1.6 mm ($4\frac{1}{2} \pm \frac{1}{16}$ in.) diameter, 25.4 ± 1.6 mm ($1 \pm \frac{1}{16}$ in.) deep.

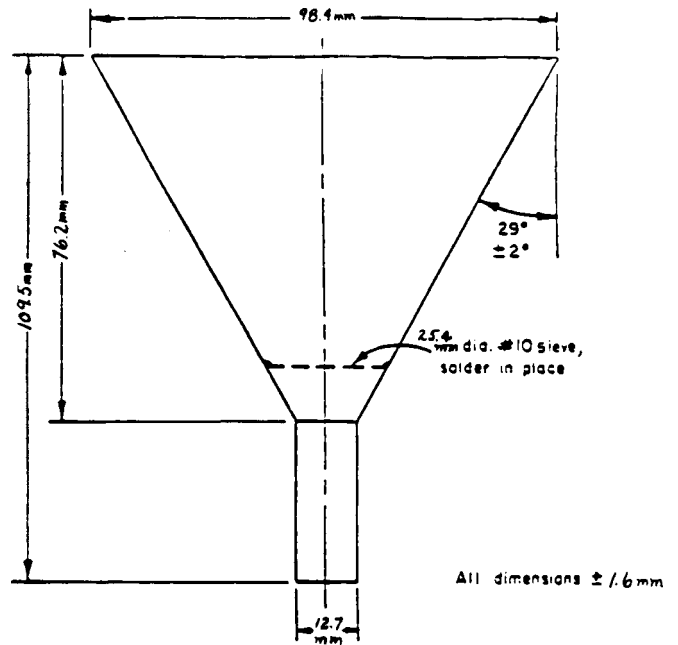

FIG. 2 Detailed Drawing for Metal Funnel

6. Materials

6.1 *Kerosine*.

6.2 *Lubricating Oil*, SAE No. 10 (see Note 1).

6.3 *Filter Paper*, size 5½-cm diameter, Type 1, Class B.

NOTE 2—VWR Guide No. 613 satisfies ASTM grade Type 1, Class B, Specification E832.

7. Hazards

7.1 **Warning**—Kerosine is flammable, and therefore caution should be used in storage and use.

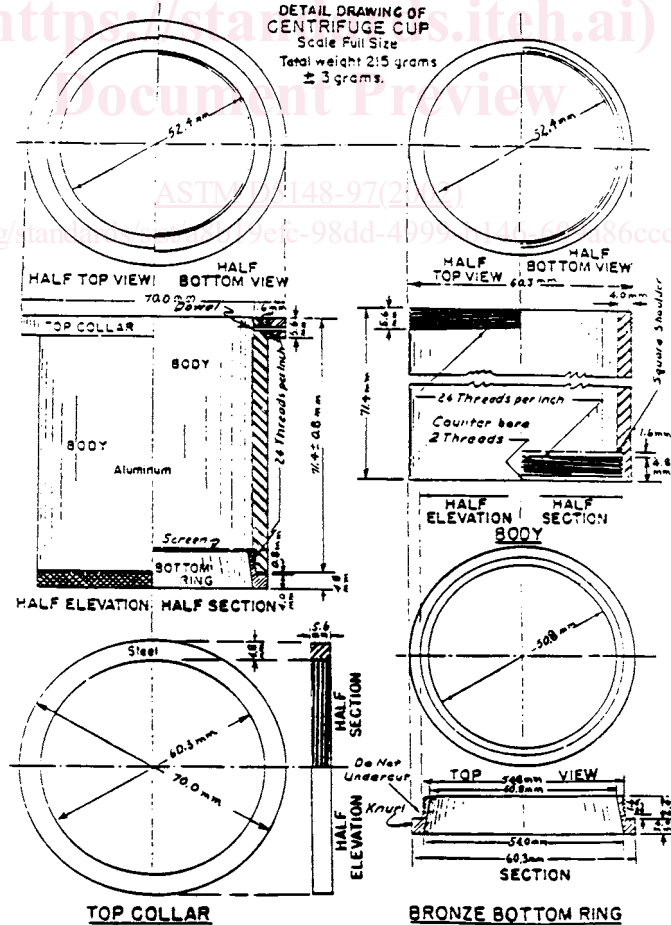

FIG. 1 Detailed Drawing of a Centrifuge Cup

8. Sampling

- 8.1 Sampling is done in accordance with Practice **D75**.
- 8.2 Reduce the sample in accordance with Practice **C702**.

9. Preparation of Sample

9.1 Determine the bulk specific gravity of the coarse aggregate (4.1) and apparent specific gravity of the fine aggregate (4.2), using Test Methods **C127** and **C128**, respectively.

NOTE 3—Apparent specific gravity is used for the fine aggregate because it is easier to determine than the bulk specific gravity, and its use does not affect the CKE results.

9.2 *Specific Gravity*—Calculate the average specific gravity for the aggregate based upon the design grading by the following formula:

$$G = \frac{1}{\frac{P_c}{100G_c} + \frac{P_f}{100G_f}} \quad (1)$$

where:

- G = average specific gravity,
- P_c = coarse aggregate present in the original sample, weight %,
- P_f = fine aggregate present in the original sample, weight %,
- G_c = bulk (oven dry) specific gravity of the coarse aggregate, and
- G_f = apparent specific gravity of the fine aggregate.

9.3 Separate the aggregate into two size groups, “C” material (used for K_c determinations) passing the 3/8-in. (9.5-mm) sieve and retained on the No. 4 (4.75-mm) sieve, and “F” material (for K_f determination) all passing the No. 4 (4.75-mm) sieve.

10. Procedures

10.1 Procedure for Fine F:

10.1.1 Quarter or split out approximately 105 g for each sample, representative of the material passing No. 4 (4.75-mm) sieve.

10.1.2 Place on hot plate or in $110 \pm 5^\circ\text{C}$ ($230 \pm 9^\circ\text{F}$) oven and dry to constant weight.

10.1.3 Allow to cool.

10.1.4 Place 100.0 ± 0.1 g in each of the tared centrifuge cups fitted with the perforated metal disk underlying a disk of filter paper.

10.1.5 Place centrifuge cups containing samples in pan with sufficient kerosine 12.7 ± 3.2 mm ($1/2 \pm 1/8$ in.) deep to saturate the sample. When specimens are thoroughly saturated (by capillary action), place the cups with samples in centrifuge. Samples should be tested in pairs, placed opposite of each other to avoid damage to the centrifuge.

10.1.6 Spin in centrifuge for 2 min at a force of 400 G.

10.1.7 Reweigh each cup, containing samples, to nearest 0.1 g and subtract original weight. The difference is the percent of kerosine retained (based on 100 g of dry aggregate). The percent of kerosine retained is the CKE value. Record the average of the two values for duplicate samples.

10.2 Procedure for Coarse C:

10.2.1 Quarter or split out approximately 105 g for each sample, representative of the material passing 3/8-in. (9.5-mm) and retained on No. 4 (4.75-mm) sieve material.

10.2.2 Dry sample on hot plate or in $110 \pm 5^\circ\text{C}$ ($230 \pm 9^\circ\text{F}$) oven to constant weight and allow to cool to room temperature.

10.2.3 Weigh out $100.0 \text{ g} \pm 0.1 \text{ g}$ and place in funnel (see 5.4).

10.2.4 Completely immerse specimen in SAE No. 10 lubricating oil for 5 min (see Note 1).

10.2.5 Place the funnel in a container, maintaining the axis in a vertical position and allow to drain for 2 min.

10.2.6 Place funnel containing sample in 60°C (140°F) oven for 15 min of additional draining, remembering to keep the funnel axis in a vertical position.

10.2.7 Pour sample from funnel into tared pan, cool to room temperature, and reweigh sample to nearest 0.1 g. Subtract original weight and record difference as percent of oil retained (based on 100 g of dry aggregate).

11. Determination of K Factors

11.1 Use the following surface area factors to calculate surface area based upon design grading as follows:

Sieve Size Passed	m ² /Kg	ft ² /lb
Maximum size	0.41	2
No. 4 (4.75 mm)	0.41	2
No. 8 (2.36 mm)	0.82	4
No. 16 (1.18 mm)	1.6	8
No. 30 (600 μm)	2.9	14
No. 50 (300 μm)	6.1	30
No. 100 (150 μm)	12.3	60
No. 200 (75 μm)	32.8	160

11.1.1 All surface area factors must be used in calculations; thus, if a sample passes No. 4 (4.75-mm) sieve 100 %, include in calculations $100 \times 0.41 \text{ m}^2/\text{kg}$ ($2 \text{ ft}^2/\text{lb}$), for passing maximum size as well as $100 \times 0.41 \text{ m}^2/\text{kg}$ ($2 \text{ ft}^2/\text{lb}$) for passing No. 4 (4.75 mm) sieve.

11.2 Use the chart shown in Fig. 3 for determination of K_f .

11.2.1 If the apparent specific gravity for F is greater than 2.70 or less than 2.60, make correction for percent of kerosine retained, using the following formula:

$$\begin{aligned} & \text{Percent of kerosine retained} \\ & \times (\text{apparent specific gravity } F/2.65) \\ & = \text{CKE corrected for specific gravity} \end{aligned} \quad (2)$$

11.2.2 Start in lower left hand corner of chart in Fig. 3 with value for CKE corrected for specific gravity, following straightedge horizontally to right to the intersection with calculated surface area, hold point, move vertically upward to the intersection with the percent passing the No. 4 (4.75-mm) sieve, hold point, and follow straightedge horizontally to right. The value obtained will be the surface constant for the passing No. 4 (4.75-mm) fraction F and is known as K_f .

11.3 Use chart shown in Fig. 4 for determination of K_c .

11.3.1 If the bulk (oven dry) specific gravity for C is greater than 2.70 or less than 2.60, apply correction to oil retained, using formula at top of chart in Fig. 4.

11.3.2 Start at the bottom of chart in Fig. 4 with the corrected percent of oil retained, follow straightedge vertically