

---

---

**Agricultural irrigation equipment — Float  
type air release valves**

*Matériel agricole d'irrigation — Vannes de purge d'air à flotteur*

**iTeh STANDARD PREVIEW**  
**(standards.iteh.ai)**

[ISO 11419:1997](https://standards.iteh.ai/catalog/standards/sist/8e88b934-9507-441b-8b4e-9606a30e2b68/iso-11419-1997)

<https://standards.iteh.ai/catalog/standards/sist/8e88b934-9507-441b-8b4e-9606a30e2b68/iso-11419-1997>



## Foreword

ISO (the International Organization for Standardization) is a worldwide federation of national standards bodies (ISO member bodies). The work of preparing International Standards is normally carried out through ISO technical committees. Each member body interested in a subject for which a technical committee has been established has the right to be represented on that committee. International organizations, governmental and non-governmental, in liaison with ISO, also take part in the work. ISO collaborates closely with the International Electrotechnical Commission (IEC) on all matters of electrotechnical standardization.

Draft International Standards adopted by the technical committees are circulated to the member bodies for voting. Publication as an International Standard requires approval by at least 75 % of the member bodies casting a vote.

iTeh STANDARD PREVIEW

International Standard ISO 11419 was prepared by Technical Committee ISO/TC 23, *Tractors and machinery for agriculture and forestry*, Subcommittee SC 18, *Irrigation and drainage equipment and systems*.

[ISO 11419:1997](https://standards.iteh.ai/catalog/standards/sist/8e88b934-9507-441b-8b4e-9606a30e2b68/iso-11419-1997)

<https://standards.iteh.ai/catalog/standards/sist/8e88b934-9507-441b-8b4e-9606a30e2b68/iso-11419-1997>

© ISO 1997

All rights reserved. Unless otherwise specified, no part of this publication may be reproduced or utilized in any form or by any means, electronic or mechanical, including photocopying and microfilm, without permission in writing from the publisher.

International Organization for Standardization  
Case postale 56 • CH-1211 Genève 20 • Switzerland  
Internet central@iso.ch  
X.400 c=ch; a=400net; p=iso; o=isocs; s=central

Printed in Switzerland

# Agricultural irrigation equipment — Float type air release valves

## 1 Scope

This International Standard gives the structural and operational requirements and test methods for float-type air release valves, hereinafter referred to as air release valves. These valves are intended for operation in irrigation systems with water whose temperature does not exceed 60 °C, and which may contain chemicals of the types and concentrations generally in use in irrigation.

This International Standard applies to air release valves, with a nominal size of 15 mm (1/2 inch) to 150 mm (6 inch), which are operated by a float which acts as the sealing member or which directly activates the sealing member.

iTeh STANDARD PREVIEW

This International Standard applies to air release valves which are intended to allow entry of air into the pipe system from the atmosphere ("vacuum relief") and/or release of air from the pipe system to the atmosphere.

ISO 11419:1997

## 2 Normative references

<https://standards.iteh.ai/catalog/standards/sist/8e88b934-9507-441b-8b4e-9606a30e2b68/iso-11419-1997>

The following standards contain provisions which, through reference in this text, constitute provisions of this International Standard. At the time of publication, the editions indicated were valid. All standards are subject to revision, and parties to agreements based on this International Standard are encouraged to investigate the possibility of applying the most recent editions of the standards indicated below. Members of IEC and ISO maintain registers of currently valid International Standards.

ISO 7-1:1994, *Pipe threads where pressure-tight joints are made on the threads — Part 1: Dimensions, tolerances and designation.*

ISO 2859-1:1989, *Sampling procedures for inspection by attributes — Part 1: Sampling plans indexed by acceptable quality level (AQL) for lot-by-lot inspection.*

ISO 7005-1:1992, *Metallic flanges — Part 1: Steel flanges.*

## 3 Definitions

For the purposes of this International Standard, the following definitions apply.

**3.1 air release valve:** Valve which opens automatically to allow air from the atmosphere to enter the pipeline during drainage of the pipeline and/or venting of air from the water pipeline to the atmosphere during filling or during normal operation of the pipeline under pressure.

**3.2 dual triple-function air release valve:** Air release mechanism which consists of two valves, a high-pressure continuous-acting air release valve (3.4) and a low-pressure air release valve (3.6), which are housed in one unit but operate separately in accordance with their functions.

NOTE — A dual triple-function air release valve fulfils the following functions:

- it enables continuous release of air from the pipe system at working pressure;
- it allows entry of air at a high flow rate during drainage of water from the pipe system; and
- it allows release of air at a high flow rate when the pipe system is being filled with water.

**3.3 float; float assembly:** Component within the valve body whose specific weight is less than that of water and is intended to float upon the water filling the cavity of the valve body.

NOTE — When the float seals at the relief nozzle (either directly or by means of a part of the float assembly), the force acting on the float (or the elevating force) and the other forces which develop within the valve seal the relief nozzle and prevent water from flowing out of the air release valve.

**3.4 high-pressure continuous-acting air release valve:** Air release valve with a small cross-sectional relief nozzle which releases pockets of air trapped in the pipeline in proximity to the air release valve when the water pipeline is under normal operating conditions (a prevailing hydraulic pressure within the normal working pressure range of the water pipeline), and which allows entry of air into the pipeline at a pressure lower than or equal to atmospheric pressure.

See figure 1 a).

**3.5 inlet connection:** Part of the inlet to the air release valve, or part of the valve body itself (in the bottom part of the valve) which connects the air release valve to the pipeline.

**3.6 low-pressure air release valve:** Air release valve with a large cross-sectional relief nozzle that serves to vent air trapped in the pipeline at high flow rates during filling of the pipeline and that allows entry of air at high flow rates into the pipeline when draining.

See figure 1 b).

**3.7 maximum working pressure:** Highest pressure at the inlet of an air release valve at which the air release valve is intended to open to release air from the pipeline or to allow entry of air.

**3.8 minimum working pressure:** Lowest pressure at the valve inlet at which complete sealing is obtained.

**3.9 nominal pressure:** Maximum static pressure of the water at the inlet of an air release valve inlet which the air release valve is stated to withstand under normal service conditions.

**3.10 nominal size:** A conventional numerical designation used to indicate the size of the air release valve which is identical to the nominal diameter or threaded size of pipe which can be connected to the air release valve without an intermediate fitting.

NOTE — The nominal size of the air release valve is not related to the nominal diameter or nominal size of the pipeline from which it is intended to release air or allow air to enter.

**3.11 relief nozzle:** Aperture in the upper part of the air release valve body (or in the valve cover plate) through which air is vented from the valve, or into which air enters.

NOTE — In general, a relief nozzle serves also as the seat of the float.

**3.12 sealing seat:** Part of the relief nozzle (on the inside part of the valve body of an air release valve) against which the float seals when the relief valve is closed and which acts as a seal.

**3.13 valve body:** Part of the air release valve through whose cavity the float moves.

**3.14 inlet orifice:** The point of the smallest passage area in the air release valve located below the valve float when in the open position.

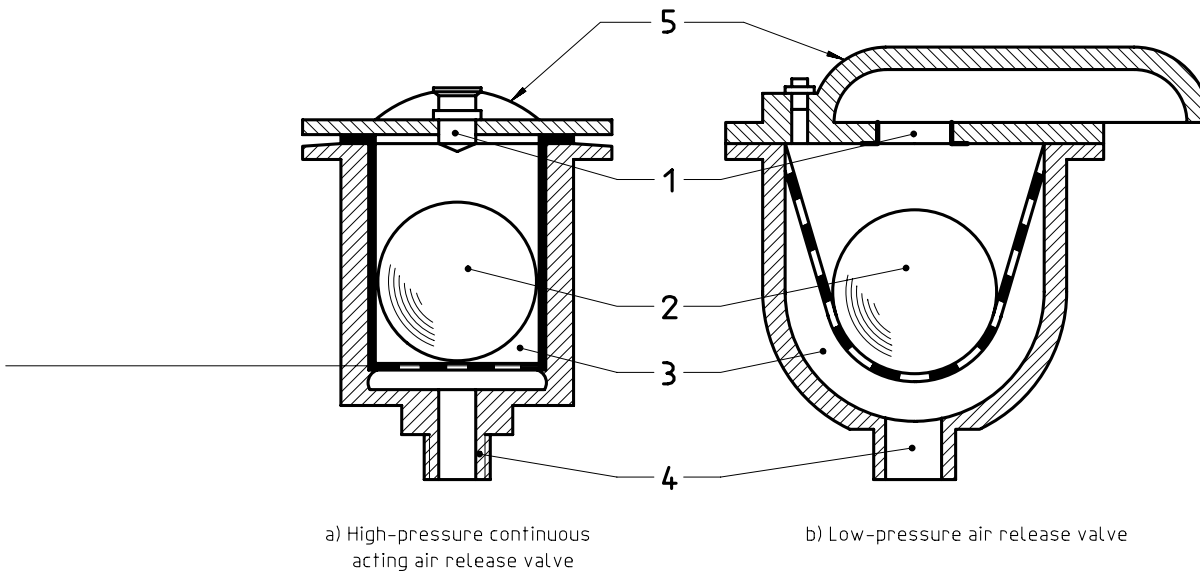

### Key

- 1 Relief nozzle
- 2 Float
- 3 Valve body
- 4 Inlet connection
- 5 Protective covers

Figure 1 — Air release valve (schematic)  
(standards.iteh.ai)

## 4 Classification

ISO 11419:1997

Air release valves are classified as follows: [standards.iteh.ai/catalog/standards/sist/8e88b934-9507-441b-8b4e-9606a30e2b68/iso-11419-1997](https://standards.iteh.ai/catalog/standards/sist/8e88b934-9507-441b-8b4e-9606a30e2b68/iso-11419-1997)

### 4.1 According to purpose of the valve

- high-pressure continuous-acting air release valve;
- low-pressure air release valve;
- dual triple-function air release valve.

### 4.2 According to nominal pressure

- 1,0 MPa
- 1,6 MPa
- 2,5 MPa

## 5 Marking

Each air release valve shall bear a clear and durable marking which shall contain the following particulars:

- a) name of manufacturer and/or the manufacturer's registered trade mark;
- b) nominal size;
- c) nominal pressure;
- d) a marking which identifies the valve model according to its purpose, as defined in 4.1, and as specified in the manufacturer's catalogue.

## 6 Technical characteristics

### 6.1 General

The parts of the air release valve coming in contact with water shall be of non-toxic materials, and shall be resistant to, or protected against, corrosion under the normal working conditions at which the valve is intended to operate.

All parts of an air release valve of the same model and nominal pressure, and which are manufactured by one manufacturer and which are intended to be removed, repaired or replaced, shall be interchangeable.

All parts of the air release valve which are made from plastics and which are exposed to ultraviolet radiation under the normal operating conditions of the valve shall contain additives to improve their resistance to ultraviolet radiation. Plastic parts of the valve which serve as water passages shall be opaque, or shall be protected in some other manner (for instance, by a closed cover) against penetration of light to the water passages.

### 6.2 Components of the air release valve

**6.2.1** The structure of the valve body and of the float shall ensure free movement of the float within the valve body cavity, except for its upper position (completely closed) and its lower position (completely open), without the possibility of the float being arrested in an intermediate position.

**6.2.2** The area of contact with the sealing seat (when the float itself serves as the seal), or that part of the float assembly which serves as a seal, shall be made of a material which shall ensure complete sealing when the air release valve is closed.

**6.2.3** Those parts which are activated to seal the air release valve shall be constructed so as to prevent seizure of the valve in the open or closed position.

**6.2.4** A low-pressure air release valve shall contain suitable means or shall be designed to prevent the float from being pushed against the relief nozzle (so as to seal it) during the release of high air flows. The area of the air passage in all parts of the low-pressure air release valve, shall be larger than the area of the inlet orifice.

**6.2.5** The air release valve shall be designed to protect the relief nozzle from damage due to an accidental external blow.

**6.2.6** It shall be possible to dismantle the air release valve for purposes of maintenance and/or replacement of the float and the relief nozzle, unless the air release valve is manufactured in such a manner so that it is not intended for dismantling and that it is stated in the manufacturer's catalogue and/or information sheets that the air release valve cannot be dismantled for maintenance and/or replacement of the float and relief nozzle.

**6.2.7** In threaded air release valves, the valve body shall be equipped with a hexagonal boss or some other suitable means of accommodating a wrench.

**6.2.8** The air release valve shall perform correctly when installed within  $\pm 5^\circ$  from a vertical position.

### 6.3 Connections

The inlet connection shall have one of the following means of connection for joining the air release valve to the pipeline:

- a) Threads for direct connection to the pipeline. The threads shall comply with ISO 7-1. However, other threads are allowed provided that a suitable adaptor is supplied with each threaded connection such that it complies with ISO 7-1.
- b) Flanges which comply with ISO 7005-1.
- c) Other forms of connection.

## 7 Construction and operating tests

### 7.1 General

For the purposes of the tests, the air release valves shall be connected to the test apparatus in a vertical position, with an allowable deviation not greater than 2°.

Unless otherwise specified, all tests shall be conducted with clean water within a temperature range of 10 °C to 30 °C. The apparatus used for measuring the various parameters shall enable measurement with a permissible error of  $\pm 2\%$  of the measured value.

### 7.2 Sampling and acceptance tests

#### 7.2.1 Type test

The representative test specimens shall be taken at random by the test laboratory from a quantity of at least 20 air release valves. The number of test specimens required for each test shall be as specified in table 1.

If the number of defective specimens in the sample is equal to or less than the acceptance number shown in table 1, the sample shall be considered as complying with the requirements of this International Standard. If the number of defective specimens in the sample is greater than the acceptance number, the sample shall be considered as not complying with the requirements of this International Standard.

#### 7.2.2 Acceptance tests

When acceptance of manufacturing lots or shipments is required, sampling shall be conducted in accordance with ISO 2859 based on AQL 2,5 and special inspection level S-4. All test specimens in the sample, selected at random according to ISO 2859:1989, table II-A, shall be tested in accordance with 7.4.

The shipment or manufacturing lot complies with this International Standard if the number of defective specimens found in the test does not exceed the acceptance number specified in ISO 2859. For the other tests, the test specimens shall be selected at random to conform with the number specified in table 1. The shipment or manufacturing lot is considered to comply with this International Standard if the number of defective specimens found in the other tests does not exceed the acceptance number specified in table 1.

**Table 1 — Required number of test specimens and acceptance number for mechanical and functional tests**

Clause/ subclause	Test	Number of specimens	Acceptance number
7.3.1	Watertightness of air release valve at nominal pressure	3	0
7.3.2	Watertightness of air release valve at minimum working pressure	2	0
7.4	Resistance of air release valve to hydrostatic pressure	5	1 1)
7.5	Resistance of air release valve to pressure at high temperature	2	0
7.6	Operating test for high-pressure air release valve	2	0
7.7	Operating test for low-pressure air release valve	2	0
7.8	Operating test for dual triple-function air release valve	2	0
8	Durability test	2	0

1) Refers only to leakage through gaskets. Damage to valve body or to valve operation is cause for rejection.

### 7.3 Watertightness

#### 7.3.1 Watertightness of air release valve at nominal pressure

Connect the air release valve to the test apparatus in which a valve is assembled close to the inlet of the air release valve. Install a pressure gauge in the vicinity of the air release valve, between the air release valve and the valve. See figure 2.

Apply hydraulic pressure gradually up to the nominal pressure. After checking to verify that the apparatus is vented of all air, seal the inlet to the air release valve hermetically with the aid of the inlet valve. Maintain this condition for 5 min. During this period, measure the pressure in the air release valve.

The pressure in the air release valve during the test shall not vary by more than 5 % of the pressure applied.

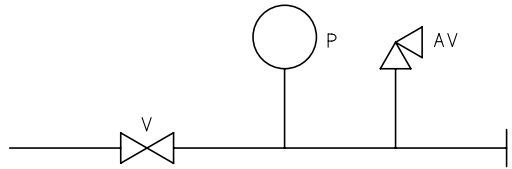

#### Key

- V Valve
- AV Air release valve
- P Pressure gauge

**Figure 2 — Test of watertightness**

### 7.3.2 Watertightness of air release valve at minimum working pressure

Connect the inlet of the valve (see figure 2) to the source of hydraulic pressure. Fill the air release valve with water, while taking care to ensure that no air remains in the system. Increase the pressure from zero to the pressure at which complete sealing is obtained and at which water no longer emerges from the relief nozzle.

The pressure at which complete sealing is obtained shall not be higher than the manufacturer's declared minimum working pressure and shall not in any case be higher than 20 kPa.

Repeat the test by application of two additional pressures. Determine the test pressures for these two tests by dividing the range between the minimum working pressure and the nominal pressure into three equal parts. Select the pressures at one-third of the range and two-thirds of the range for these two tests.

The pressure in the air release valve during the test shall not vary by more than 5 % of the pressure applied.

### 7.4 Resistance of air release valve to hydrostatic pressure

#### 7.4.1 Air release valve with a metal body

Connect the valve to the test apparatus and apply a gradually increasing hydraulic pressure at its inlet up to 1,6 times the nominal pressure declared by the manufacturer, while ensuring that no air remains in the system. Maintain this pressure for 5 min.

The seals shall not be displaced nor damaged.

#### 7.4.2 Air release valve with a plastic body (all or part)

The specifications for hydrostatic testing of air release valves with a plastic body are at present under study and will be added to this International Standard at a later date. Until then, air release valves with a plastic body shall be tested in the same manner as for metal air release valves, as specified in 7.4.1.

### 7.5 Resistance of air release valve to pressure at high temperature

**7.5.1** Connect the air release valve to the test apparatus and immerse the valve in a hot water bath at a temperature of 60 °C. Increase the water pressure in the valve up to the nominal pressure multiplied by 0,7, while ensuring that no air remains in the system. Maintain these test conditions for a continuous period of 100 h.

There shall be no leakage from the air release valve during the test.



### 7.5.2 Dismantle the valve and examine the parts visually.

The sealing component of the float assembly shall not adhere to the sealing seat. There shall be no indications in the valve of deformations or other defects; neither shall there be any deformation or defects in the plastics or elastomer parts.

## 7.6 Operating test for high-pressure air release valve

Connect the air release valve to a test apparatus which enables application of a water pressure equal to at least the nominal pressure and which also enables air to be injected into the air release valve. Immerse the air release valve in a water bath.

**7.6.1** Apply hydraulic pressure at the inlet of the air release valve. Inject air into the air release valve until air bubbles appear at the relief nozzle in the water bath. Pass the air through the valve for 5 s and then stop the air flow.

After expelling all air bubbles, remove the air release valve from the bath and test the valve for watertightness in accordance with 7.3.1.

The air release valve shall be watertight and there shall be no leakage of water through the relief nozzle.

**7.6.2** Repeat the test performed in accordance with 7.6.1, once with the water pressure equal to the maximum pressure, once with the water pressure equal to 0,50 times the maximum working pressure and once with the water pressure equal to 0,75 times the maximum working pressure.

**7.6.3** Repeat the test according to 7.6.1 with the air release valve forming the maximum permissible angle with the vertical axis as stated by the manufacturer (otherwise  $\pm 5^\circ$ ).

## 7.7 Operating test for low-pressure air release valve

**7.7.1** Connect the air release valve to the test apparatus between the two valves as shown in figure 3. Connect the inlet of valve No. 1 to the supply source. Connect valve No. 2 so as to enable it to be opened to the atmosphere. Connect a graduated transparent tube, about 2 000 mm long and with an internal diameter of about 30 mm, above the relief nozzle between valve No. 1 and the air release valve, through a third valve, valve No. 3. Install a pressure gauge.

**7.7.2** Close valves No. 1 and No. 2. Fill the air release valve with water by pouring water through the transparent tube at a low flow rate of about 1 l/min, while measuring the height of the water in the tube. Record the height of the water in the tube at the moment that the float seals the relief nozzle.

If the air release valve does not seal when the water in the tube reaches a height of 2 000 mm, close valve No. 3 and increase the pressure in the apparatus by opening valve No. 1. Record the reading on the pressure gauge at the moment the float seals the relief nozzle.

The pressure (the elevation of the water in the graduated transparent tube) at the moment of sealing the air release valve shall not differ from the manufacturer's declared minimum pressure by more than  $\pm 20\%$ .

**7.7.3** Increase the pressure in the apparatus through valve No. 1 until the nominal pressure is obtained. Maintain these test conditions for 5 min. Close valve No. 1 and open valve No. 2 so that the apparatus is at atmospheric pressure.

The float of the air release valve shall drop so as to open the relief nozzle.

**7.7.4** Repeat the test described in 7.7.2 and 7.7.3 on the same air release valves three times in the same test conditions and once again with the air release valve inclined from the vertical at the maximum angle declared by the manufacturer (or  $\pm 5^\circ$  if not otherwise declared).