



Designation: C 680 – 89 (Reapproved 1995)^{ε1}

Standard Practice for Determination of Heat Gain or Loss and the Surface Temperatures of Insulated Pipe and Equipment Systems by the Use of a Computer Program¹

This standard is issued under the fixed designation C 680; the number immediately following the designation indicates the year of original adoption or, in the case of revision, the year of last revision. A number in parentheses indicates the year of last reapproval. A superscript epsilon (ϵ) indicates an editorial change since the last revision or reapproval.

^{ε1} NOTE—Safety Caveat and Keywords were added editorially in April 1995.

1. Scope

1.1 The computer programs included in this practice provide a calculational procedure for predicting the heat loss or gain and surface temperatures of insulated pipe or equipment systems. This procedure is based upon an assumption of a uniform insulation system structure, that is, a straight run of pipe or flat wall section insulated with a uniform density insulation. Questions of applicability to real systems should be resolved by qualified personnel familiar with insulation systems design and analysis. In addition to applicability, calculational accuracy is also limited by the range and quality of the physical property data for the insulation materials and systems.

1.2 *This standard does not purport to address all of the safety concerns, if any, associated with its use. It is the responsibility of the user of this standard to establish appropriate safety and health practices and determine the applicability of regulatory limitations prior to use.*

2. Referenced Documents

2.1 ASTM Standards:

- C 168 Terminology Relating to Thermal Insulating Materials²
- C 177 Test Method for Steady-State Heat Flux Measurements and Thermal Transmission Properties by Means of the Guarded Hot Plate Apparatus²
- C 335 Test Method for Steady-State Heat Transfer Properties of Horizontal Pipe Insulation²
- C 518 Test Method for Steady-State Heat Flux Measurements and Thermal Transmission Properties by Means of the Heat Flow Meter Apparatus²
- C 585 Practice for Inner and Outer Diameters of Rigid Thermal Insulation for Nominal Sizes of Pipe and Tubing (NPS System)²
- E 691 Practice for Conducting an Interlaboratory Study to

¹ This practice is under the jurisdiction of ASTM Committee C-16 on Thermal Insulation and is the direct responsibility of Subcommittee C16.30 on Thermal Measurements.

Current edition approved Jan. 27, 1989. Published May 1989. Originally published as C 680 – 71. Last previous edition C 680 – 82^{ε1}.

² *Annual Book of ASTM Standards*, Vol 04.06.

Determine the Precision of a Test Method³

2.2 ANSI Standards:

- X3.5 Flow Chart Symbols and Their Usage in Information Processing⁴
- X3.9 Standard for Fortran Programming Language⁴

3. Terminology

3.1 *Definitions*—For definitions of terms used in this practice, refer to Terminology C 168.

3.2 *Symbols: Symbols*—The following symbols are used in the development of the equations for this practice. Other symbols will be introduced and defined in the detailed description of the development.

where:

- h = surface coefficient, Btu/(h-ft²·°F) (W/(m²·K))
- k = thermal conductivity, Btu-in./(h-ft²·°F)(W/(m·K))
- k_a = constant equivalent thermal conductivity introduced by the Kirchhoff transformation, Btu-in./(h-ft²·°F) (W/(m·K))
- Q_t = total time rate of heat flow, Btu/h (W)
- Q_l = time rate of heat flow per unit length, Btu/h-ft (W/m)
- q = time rate of heat flow per unit area, Btu/(h-ft²) (W/m²)
- R = thermal resistance, (°F·h-ft²)/Btu (K·m²/W)
- r = radius, in. (m)
- t = local temperature, °F (K)
- t_i = temperature of inner surface of the insulation, °F (K)
- t_a = temperature of ambient fluid and surroundings, °F (K)
- x = distance in direction of heat flow (thickness), in. (m)

4. Summary of Practice

4.1 The procedures used in this practice are based upon standard steady-state heat transfer theory as outlined in textbooks and handbooks. The computer program combines the functions of data input, analysis, and data output into an

³ *Annual Book of ASTM Standards*, Vol 14.02.

⁴ Available from American National Standards Institute, 11 W. 42nd St., 13th Floor, New York, NY 10036.

easy-to-use, interactive computer program. By making the program interactive, little operator training is needed to perform fast, accurate calculations.

4.2 The operation of the computer program follows the procedure listed below:

4.2.1 *Data Input*—The computer requests and the operator inserts information that describes the system and operating environment. The data include:

4.2.1.1 Analysis Identification.

4.2.1.2 Date.

4.2.1.3 Ambient Temperature.

4.2.1.4 Surface coefficient or ambient wind speed, insulation system surface emittance, and orientation.

4.2.1.5 *System Description*—Layer number, material, and thicknesses.

4.2.2 *Analysis*—Once input data is entered, the program calculates the surface coefficients (if not entered directly) and the layer resistances, then uses that data to calculate the heat losses and surface temperatures. The program continues to repeat the analysis using the previous temperature data to update the estimates of layer resistance until the temperatures at each surface repeat with a specified tolerance.

4.2.3 Once convergence of the temperatures is reached, the program prints a table giving the input data, the resulting heat flows, and the inner surface and external surface temperatures.

5. Significance and Use

5.1 Manufacturers of thermal insulations express the performance of their products in charts and tables showing heat gain or loss per lineal foot of pipe or square foot of equipment surface. These data are presented for typical operating temperatures, pipe sizes, and surface orientations (facing up, down, or horizontal) for several insulation thicknesses. The insulation surface temperature is often shown for each condition, to provide the user with information on personnel protection or surface condensation. Additional information on effects of wind velocity, jacket emittance, and ambient conditions may also be required to properly select an insulation system. Due to the infinite combinations of size, temperature, humidity, thickness, jacket properties, surface emittance, orientation, ambient conditions, etc., it is not practical to publish data for each possible case.

5.2 Users of thermal insulation, faced with the problem of designing large systems of insulated piping and equipment, encounter substantial engineering costs to obtain the required thermal information. This cost can be substantially reduced by both the use of accurate engineering data tables, or by the use of available computer analysis tools, or both.

5.3 The use of analysis procedures described in this practice can also apply to existing systems. For example, C 680 is referenced for use with Procedures C 1057 and C 1055 for burn hazard evaluation for heated surfaces. Infrared inspection or in situ heat flux measurements are often used in conjunction with C 680 to evaluate insulation system performance and durability on operating systems. This type analysis is often made prior to system upgrades or replacements.

5.4 The calculation of heat loss or gain and surface temperature of an insulated system is mathematically complex and

because of the iterative nature of the method, is best handled by computers.

5.5 The thermal conductivity of most insulating materials changes with mean temperature. Since most thermal insulating materials rely on enclosed air spaces for their effectiveness, this change is generally continuous and can be mathematically approximated. In the cryogenic region where one or more components of the air condense, a more detailed mathematical treatment may be required. For those insulations that depend on high molecular weight, that is, fluorinated hydrocarbons, for their insulating effectiveness, gas condensation will occur at higher temperatures and produce sharp changes of conductivity in the moderate temperature range. For this reason, it is necessary to consider the temperature conductivity dependence of an insulation system when calculating thermal performance. The use of a single value thermal conductivity at the mean temperature will provide less accurate predictions, especially when bridging regions where strong temperature dependence occurs.

5.6 The use of this practice by both manufacturers and users of thermal insulations will provide standardized engineering data of sufficient accuracy for predicting thermal insulation performance.

5.7 Computers are now readily available to most producers and consumers of thermal insulation to permit the use of this practice.

5.8 Two separate computer programs are described in this practice as a guide for calculation of the heat loss or gain, and surface temperatures, of insulated pipe and equipment systems. The range of application of these programs and the reliability of the output is a primary function of the range and quality of the input data. Both programs are intended for use with an “interactive” terminal. With this system, intermediate output guides the user to make programming adjustments to the input parameters as necessary. The computer controls the terminal interactively with program-generated instructions and questions, prompting user response. This facilitates problem solution and increases the probability of successful computer runs.

5.8.1 Program C 608E is designed for an interactive solution of equipment heat transfer problems.

5.8.2 Program C 608P is designed for interactive solution of piping-system problems. The subroutine SELECT has been written to provide input for the nominal iron pipe sizes as shown in Practice C 585, Tables 1 and 3. The use of this program for tubing-systems problems is possible by rewriting subroutine SELECT such that the tabular data contain the appropriate data for tubing rather than piping systems (Practice C 585, Tables 2 and 4).

5.8.3 Combinations of the two programs are possible by using an initial selector program that would select the option being used and elimination of one of the k curve and surface coefficient subroutines that are identical in each program.

5.8.4 These programs are designed to obtain results identical to the previous batch program of the 1971 edition of this practice. The only major changes are the use of an interactive terminal and the addition of a subroutine for calculating surface coefficient.

5.9 The user of this practice may wish to modify the data

input and report sections of the computer program presented here to fit individual needs. Also, additional calculations may be desired to include other data such as system costs or economic thickness. No conflict with this method in making these modifications exists, provided that the user has demonstrated compatibility. Compatibility is demonstrated using a series of test cases covering the range for which the new method is to be used. For those cases, results for the heat flow and surface temperatures must be identical, within the resolution of the method, to those obtained using the method described herein.

5.10 This practice has been prepared to provide input and output data that conforms to the system of units commonly used by United States industry. Although modification of the input/output routines would provide an SI equivalent of the heat-flow results, no such "metric" equivalent is available for the other portions of the program. To date, there is no accepted metric dimensions system for pipe and insulation systems for cylindrical shapes. The dimensions in use in Europe are the SI dimension equivalents of the American sizes, and in addition have different designations in each country. Therefore, due to the complexity of providing a standardized equivalent of this procedure, no SI version of this practice has been prepared. At the time in which an international standardization of piping and insulation sizing occurs, this practice can be rewritten to meet those needs. This system has also been demonstrated to calculate the heat loss for bare systems by the inclusion of the pipe/equipment wall thermal resistance into the equation system. This modification, although possible, is beyond the scope of this practice.

6. Method of Calculation

6.1 Approach:

6.1.1 This calculation of heat gain or loss, and surface temperature, requires (1) that the thermal insulation be homogeneous as outlined by the definition of thermal conductivity in Terminology C 168; (2) that the pipe size and equipment operating temperature be known; (3) that the insulation thickness be known; (4) that the surface coefficient of the system be known, or sufficient information be available to estimate it as described in 7.4; and (5) that the relation between thermal conductivity and mean temperature for the insulation be known in detail as described in 7.3.

6.1.2 The solution is a computer procedure calling for (1) estimation of the system temperature distribution, (2) calculation of the thermal resistances throughout the system based on that distribution, and (3) then reestimation of the temperature distribution from the calculated resistances. The iteration continues until the calculated distribution is in agreement with the estimated distribution. The layer thermal resistance is calculated each time with the equivalent thermal conductivity being obtained by integration of the conductivity curve for the layer being considered. By this technique, the thermal conductivity variation of any insulation or multiple-layer combination of insulations can be taken into consideration when calculating the heat flow.

6.2 *Development of Equations*—The development of the mathematical equations centers on heat flow through a homogeneous solid insulation exhibiting a thermal conductivity that

is dependent on temperature. Existing methods of thermal conductivity measurement account for the thermal conduction, convection, and radiation occurring within the insulation. After the basic equations are developed, they are extended to composite (multiple-layer) cases and supplemented with provision for heat flow from the outer surface by convection or radiation, or both.

6.3 Equations—Case 1, Slab Insulation:

6.3.1 Case 1 is a slab of insulation shown in Fig. 1 having width W , height H , and thickness T . It is assumed that heat flow occurs only in the thickness of x direction. It is also assumed that the temperature t_1 of the surface at x_1 is the same as the equipment surface temperature and the time rate of heat flow per unit area entering the surface at x_1 is designated q_1 . The time rate of heat flow per unit area leaving the surfaces at x_2 is q_2 .

6.3.1.1 For the assumption of steady-state (time-independent) condition, the law of conservation of energy dictates that for any layer the time rate of heat flow in must equal the time rate of heat flow out, i.e., there is no net storage of energy inside the layer.

6.3.1.2 Taking thin sections of thickness Δx , energy balances may be written for these sections as follows:

Case 1:

$$(WHq)|_x - (WHq)|_{x+\Delta x} = 0 \tag{1}$$

NOTE 1—The vertical line with a subscript indicates the point at which the previous parameter is evaluated. For example: $q|_{x+\Delta x}$ reads the time rate of heat flow per unit area, evaluated at $x + \Delta x$.

6.3.1.3 After dividing Eq 1 by $-WH\Delta x$ and taking the limit as Δx approaches zero, the differential equation for heat transfer is obtained for the one-dimensional case:

$$(d/dx)q = 0 \tag{2}$$

6.3.1.4 Integrating Eq 2 and imposing the condition of heat flow stability on the result yields the following:

$$q = q_1 = q_2 \tag{3}$$

Case 1

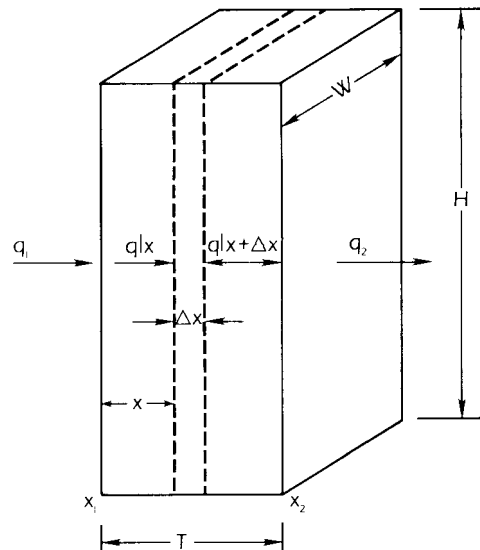

FIG. 1 Single Layer Slab System

6.3.1.5 When the thermal conductivity, k , is a function of local temperature, t , the Fourier law must be substituted in Eq 2. Fourier's Law for one-dimensional heat transfer can be stated mathematically as follows:

$$q = -k(dt/dx) \quad (4)$$

therefore,

$$(d/dx)q = (d/dx)(-k(dt/dx)) = 0 \quad (5)$$

6.3.1.6 To retain generality, the functionality of k with t is not defined at this point, therefore, Eq 5 cannot be integrated directly. The Kirchhoff transformation (1)⁵ allows integration by introducing an auxiliary variable u and a constant k_a defined by the differential equation as follows:

$$k_a(du/dx) = k(dt/dx) \quad (6)$$

This equation must be satisfied by the following boundary conditions:

$$u = t_1 \text{ at } x = x_1$$

$$u = t_2 \text{ at } x = x_2$$

6.3.1.7 Rederiving Eq 4 in terms of Eq 6, integrating, and imposing the boundary conditions for the transformation yields the following:

$$q_1 = \frac{t_1 - t_2}{\left[\frac{x_1 - x_2}{k_a} \right]} \quad (7)$$

6.3.1.8 Eq 7 is in a familiar form of the conductive heat transfer equation used when thermal conductivity is assumed constant with local temperatures. To evaluate the equivalent thermal conductivity, Eq 6 is solved for k_a . Separating variables in either equation and integrating through the boundary conditions, the following general relation is obtained:

$$k_a = \frac{1}{t_2 - t_1} \int_{t_1}^{t_2} k dt \quad (8)$$

Evaluation of the integral in Eq 8 can be handled analytically where k is a simple function, or by numerical methods where k cannot be integrated. Particular solutions of Eq 8 are discussed in 6.5.

6.3.2 The equations for heat flow through a single-layer insulation can now be extended to the multiple layer or composite insulation case. Consider Fig. 2 as a multiple-layer extension of the simple case. The figure shows the composite system with insulations having different thermal conductivities.

6.3.2.1 Equations can be written for each additional layer analogous to Eq 7. With the entire system at stability and assuming no temperature drop across layer interfaces, the equation is written as follows:

$$q_{i+1} = \frac{t_i - t_{i+1}}{\left(\frac{x_i - x_{i+1}}{k_{a,i,i+1}} \right)} \quad (9)$$

NOTE 2—The generalized index, i , denotes any interface within the system.

6.3.2.2 It is useful at this point to introduce the concept of thermal resistance, that is, the heat flow per unit area given

⁵ The boldface numbers in parentheses refer to the list of references at the end of this practice.

Case 1

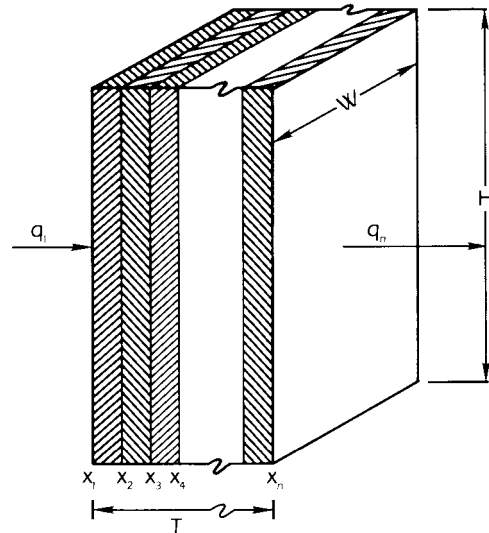

FIG. 2 Composite System Slab

simply by a temperature difference divided by the corresponding thermal resistance. The heat flow per unit area at the outer surface, x_n , is calculated as follows:

$$q_n = (t_i - t_{i+1})/R_{i,i+1} \quad (10)$$

where:

$$R_{i,i+1} = (x_{i+1} - x_i)/k_{a,i,i+1} \quad (11)$$

6.3.3 Characterization of the heat flow from the systems can be completed by developing an expression for the rate of heat flow per unit area at the outer solid surfaces. For this purpose, the following definition of the surface coefficient is employed:

$$h = q_n/(t_n - t_a) \quad (12)$$

or

$$q_n = \frac{(t_n - t_a)}{(1/h)} \quad (13)$$

Because of the similarity between Eq 10 and Eq 13, Eq 13 can be rewritten as follows:

$$q_n = (t_n - t_a)/R_s \quad (14)$$

where:

$$R_s = (1/h) \quad (15)$$

6.3.4 The surface coefficient, h , is a complex function of the properties of the ambient fluid, surface geometry, the temperatures of the system, the surface finish, and motion of the ambient fluid. Equations used by this practice for estimating the surface coefficient are discussed in 7.4.

6.3.4.1 Summing the series of equations from 6.3.2 including equations from 6.3.3 yields the following expression for the heat flow through the entire composite system:

$$q_n = (t_1 - t_a)/R_t \quad (16)$$

where:

$$R_t = R_{1,2} + R_{2,3} + R_{3,4} + \dots + R_{n-1,n} + R_s$$

6.3.4.2 Setting the heat flow per unit area through each element, q_i , equal to the heat flow through the entire system, q_n ,

shows that the ratio of the temperature across the element to the temperature difference across the entire system is proportional to the ratio of the thermal resistance of the element to the total thermal resistance of the system or in general terms.

$$\frac{(t_i - t_{i+1})}{(t_1 - t_a)} = (R_{i,i+1} / R_t) \tag{17}$$

Eq 17 provides the means of solving for the temperature distribution. Since the resistance of each element depends on the temperature of the element, the solution can be found only by iteration methods.

6.4 Equations—Case 2, Cylindrical Sections:

6.4.1 For Case 2, Figs. 3 and 4, the analysis used is similar to that described in 6.3, but with the replacement of the variable x by the cylindrical coordinate, r . The following generalized equation is used to calculate the conductive heat flow through a layer of a cylinder wall.

$$q_{i+1} = \frac{t_i - t_{i+1}}{\left(\frac{r_{i+1} \ln(r_{i+1}/r_i)}{k_{a,i,i+1}} \right)} \tag{18}$$

Note the similarity of Eq 9 and Eq 18 and that the solution of the transformation equation for the radial heat flow case is identical to that of the slab case (see Eq 8).

6.4.2 As in Case 1, calculations for slabs, simplification of the equations for the heat loss may be accomplished by defining the thermal resistance. For pipe insulations, the heat flow per unit area is a function of radius, so thermal resistance must be defined in terms of the heat flow at a particular radius. The outer radius, r_n , of the insulation system is chosen for this purpose. The heat flow per unit area for cylinders, calculated at the outer surface, r_n , is:

$$q_n = (t_i - t_{i+1}) / R_{i,i+1} \tag{19}$$

where:

$$R_{i,i+1} = \frac{r_n \ln(r_{i+1}/r_i)}{k_{a,i,i+1}} \tag{20}$$

6.4.3 The concept of surface resistance used in an analysis similar to 6.3.3 and 6.3.4 permits introduction of the definition of the heat transfer as a function of the overall thermal resistance for the cylindrical case as follows:

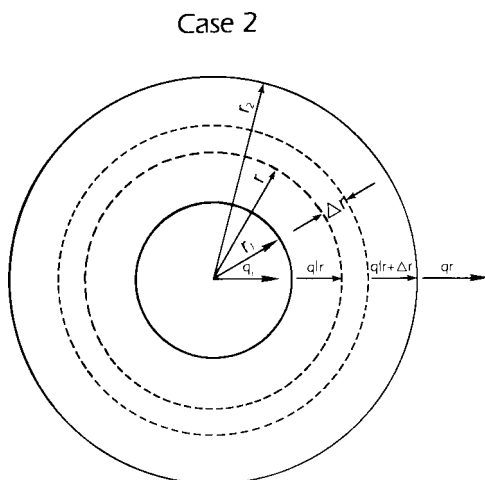

FIG. 3 Single Layer Annulus System

Case 2

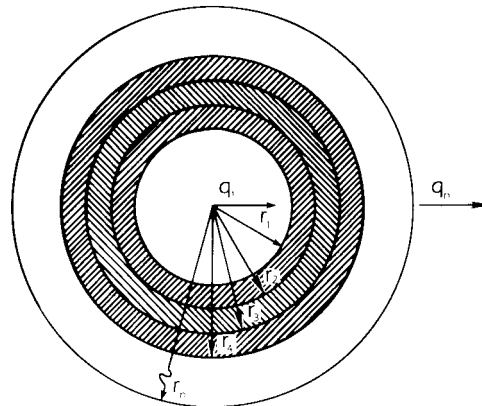

FIG. 4 Composite System Annulus

$$q_n = (t_1 - t_a) / R_t \tag{21}$$

where:

$$R_t = R_{1,2} + R_{2,3} + R_{3,4} + \dots + R_{n-1,n} + R_s$$

NOTE 3—In some situations where comparisons of the insulation system performance is to be made, basing the areal heat loss on the inside surface area, which is fixed by the pipe dimensions, or on the heat loss per unit length, is beneficial. The heat loss per unit area of the inside surface is calculated from the heat loss per unit area of the outside surface by multiplying by the ratio of the outside radius to the inside radius. For calculation of the heat loss per linear foot from the heat loss per outside area, simply multiply by the outside area per foot or $2\pi r_o$. For Case 2, the annulus, results are normally expressed as the time rate of heat flow per unit length, Q_1 , which is obtained as follows:

$$Q_1 = 2\pi r_n q_n = 2\pi r_n (t_1 - t_2) / R_t \tag{22}$$

6.5 Calculation of Effective Conductivity:

6.5.1 In Eq 11-22 it is necessary to evaluate k_a as a function of temperature for each of the conductive elements. The generalized solution in Eq 8 is as follows:

$$k_{a,i,i+1} = \frac{1}{(t_{i+1} - t_i)} \int_{t_i}^{t_{i+1}} k dt$$

6.5.2 When k may be described in terms of a simple function of t , an analytically exact solution for k_a can be obtained. The following functional types will be considered in the examples (see 9.1-9.4).

6.5.2.1 If k is linear with t , $k = a + bt$ and

$$k_a = \frac{1}{(t_{i+1} - t_i)} \int_{t_i}^{t_{i+1}} (a + bt) dt = a + b \left(\frac{t_{i+1} + t_i}{2} \right) \tag{23}$$

where a and b are constants.

6.5.2.2 If

$$k = e^{a+bt}$$

then:

$$k_a = \frac{1}{(t_{i+1} - t_i)} \int_{t_i}^{t_{i+1}} e^{a+bt} dt$$

and evaluating the integral yields:

$$k_a = \left[\frac{1}{(t_{i+1} - t_i)} \right] \left[\frac{e^{a+bt_{i+1}} - e^{a+bt_i}}{b} \right] \tag{24}$$

where a and b are constants, and e is the base of the natural logarithm.

6.5.2.3 If

$$k = a + bt + ct^2$$

then:

$$k_a = \frac{1}{(t_{i+1} - t_i)} \int_{t_i}^{t_{i+1}} (a + bt + ct^2) dt$$

and evaluating the integral yields:

$$k_a = a + \frac{b}{2}(t_{i+1} + t_i) + \frac{c}{3} \frac{(t_{i+1}^3 - t_i^3)}{(t_{i+1} - t_i)} \quad (25)$$

where a , b , and c are constants.

6.5.3 When the relationship of k with t is more complex and does not lend itself to simple mathematical treatment, a numerical method may be used. It is in these cases that the power of the computer is particularly useful. There are a wide variety of numerical techniques available. The most suitable will depend on the particular situation, and the details of the factors affecting the choice are beyond the scope of this practice.

7. Input Data

7.1 In general, data input is in accordance with ASTM Standards or American National Standards. The source of other required data is noted.

7.2 Dimensions of Pipe and Pipe Insulation:

7.2.1 Only nominal pipe sizes and insulation thicknesses are required as input data. The actual dimensions of both pipe and pipe insulation are obtained by the computer from a software file based on Practice C 585 during the calculation.

7.3 Thermal Conductivity Versus Mean Temperature:

7.3.1 The data describing the relationship of thermal conductivity to mean temperature are obtained in accordance with Test Methods C 177, C 335, or C 518, as appropriate for the product.

7.3.2 To describe accurately the relationship of thermal conductivity to mean temperature for thermal insulations, especially those exhibiting inflection points due to condensations of the insulating gases, thermal conductivity tests at small temperature differences are required. The minimum temperature differences used will depend on the vapor pressure to temperature of the gases involved, and the accuracy of the test apparatus at small temperature differences. Sufficient tests must be made to characterize the conductivity versus mean temperature relationship over the desired temperature range.

NOTE 4—ASTM Committee C-16 is currently developing recommendations for preparing thermal conductivity curves for use in systems analysis. Although the exact procedures are beyond the scope of this practice, caution should be exercised. The use of experimental data to generate curves must include consideration of test sample geometry, temperature range of data, test temperature differentials, thickness effects, test boundary conditions, and test equipment accuracy. Especially important is that the test data should cover a temperature range of conditions wider than those of the analysis, so that the data is interpolated for the analysis rather than extrapolated.

7.4 Surface Coefficients:

7.4.1 The surface coefficient, h , as defined in Definitions C 168, assumes that the surroundings (fluid and visible surfaces) are at uniform temperature and that other visible surfaces are substantially perfect absorbers of radiant energy. It

includes the combined effects of radiation, conduction, and convection.

7.4.2 In many situations surface coefficients may be estimated from published values (2).

7.4.3 *Procedures for Calculating Surface Coefficients*—Where known surface coefficients are not available, this practice provides a calculational procedure to estimate the surface coefficient. This calculation is based on the assumption of heat flow from a uniformly heated surface. This assumption is consistent with those used in developing the remainder of this practice. In simple terms, the surface coefficient equations are based on those commonly used in heat transfer analysis. A detailed discussion of the many heat flow mechanisms is present in several texts (3, 4, 5) or similar texts.

7.4.4 *Analysis Configurations*—Several convective conditions have been identified as requiring separate treatment when calculating the surface coefficient. The first is the two geometries treated in this method, that is, flat (equipment) and circular cylinder (pipe). Another case identifies the two air flow systems common to most applications. Free convection is defined as air motion caused by the bouyancy effects induced by the surface-to-air temperature difference. This case is characterized by low velocity and, for most cases, includes any situation where the local air velocity is less than 1 mph (0.5 m/s). Forced convection is where some outside agent causes the air movement. For high air velocities, convection is the dominant mechanism of heat flow from the surface. The radiative heat flow surface coefficient is calculated separately and added to the convection losses since for a vast majority of cases, this mechanism operates independently of the convective transfer.

7.4.5 *Surface Coefficient Calculation—Summary of Method*—The convection coefficient calculation subroutine, SURCOF, developed for this practice, estimates the magnitude of the convection coefficient based upon the equations for the given set of geometric conditions and temperature-dependent air properties. The radiative component is also determined and added to yield the net surface coefficient. All equations used in the analysis (3) were experimentally developed. The equations used are briefly described in 7.4.7-7.4.9.

7.4.6 Alternative equation sets have been developed to calculate the surface heat transfer coefficients. These equation sets often include parameters in addition to those used in the development of the SURCOF subroutine described in this practice. These additional parameters are used to extend the data set to a wider range of conditions or better fit the data available. Use of these alternate equation sets instead of the SURCOF subroutine equation set is permitted, providing adequate documentation is provided and similarity of results is demonstrated under the exposure conditions covered by the SURCOF documentation (See Appendix X1) (3).

7.4.7 Convection:

7.4.7.1 *Forced Convection*—One of the major contributors to surface heat transfer is the convection of air across a surface where some difference exists between their temperatures. Not only is the rate of heat flow controlled by the magnitude of the temperature difference but also by the speed of the air flow as

it passes the surface. Since convection is a complex phenomena and has been studied by many researchers, many empirically developed equations exist for estimating the surface coefficients. One of the simpler to apply and more commonly used system of equations is that developed by Langmuir (6). His equations were developed for conditions of moderate temperatures which are most commonly seen in cases of insulated piping or equipment systems. For the condition of the natural convection of air at moderate temperature Langmuir proposed the following equation:

$$Q_c = 0.296(t_s - t_a)^{1.25} \tag{26}$$

where:

Q_c = heat transferred by natural convections, Btu/ft² (J/m²),
 t_s = temperature of surface, °F (°C), and
 t_a = temperature of ambient, °F (°C).

7.4.7.2 *Modifications for Forced Convection*—When the movement of the air is caused by some outside force such as the wind, forced ventilation systems, etc. Langmuir (6) presented a modifier of Eq 26 to correct it for the forced convection. This multiplier was stated as follows:

$$\sqrt{\frac{V + 68.9}{68.9}}$$

where V is the bulk air velocity (ft/min). In a more commonly presented form where the velocity is miles per hour, this correction term reduces to

$$\sqrt{1.00 + 1.277 \times \text{Wind}} \tag{27}$$

where Wind = air movement speed (mph).

Combining Eq 26 and Eq 27, we have Langmuir's (6) equation for the convection heat transfer from a surface:

$$Q_c = 0.296(t_s - t_a)^{1.25} \sqrt{1 + 1.277 \times \text{Wind}} \tag{28}$$

This equation will work for both forced and free convection because when Wind equals zero, the equation returns to its original form.

7.4.7.3 *Convection for Geometric Variations*—Further research by Rice and Heilman (7) refined the technology of Langmuir to account for changes in air film properties (density, thickness, viscosity) with the air film mean temperature. Also their refinements provided corrections to the equation form for geometric size, shape, and heat flow directions that permit use of the basic form of Langmuir's (6) equation for a host of conditions. The result of their research yields the following equation set which forms the basis for the surface coefficient routines used in this practice.

$$h_{cv} = C \times \left(\frac{1}{d}\right)^{0.2} \times \left(\frac{1}{t_{avg}}\right)^{0.181} \times \Delta t^{0.266} \times \sqrt{1 + 1.277 \times \text{Wind}} \tag{29}$$

where:

h_{cv} = convective surface coefficient, Btu/h·ft²·°F (W/m²·K),

d = diameter for cylinder, in. (m). For flat surfaces and large cylinders $d > 24$, use $d = 24$,

t_{avg} = average temperature of air film, °F (°C) = $(t_s + t_a)/2$, and

Δt = surface-to-air temperature difference, °F (°C), = $(t_s - t_a)$.

7.4.7.4 The values of constant C are shown in Table 1 as a function of shape and heat flow condition.

7.4.8 *Radiative Component*—In each previous case, the radiative exchanges are for the most part independent of the convection exchange. The exception is that both help to determine the average surface temperature. The radiation coefficient is simply the radiative heat transfer rate, based upon the Stefan-Boltzman Law, divided by the average surface-to-air temperature difference. Thus the relationship can be expressed as the following:

$$h_{rad} = \frac{E_{miss} \times 0.1713 \times 10^{-8} ((t_a + 459.6)^4 - (t_s + 459.6)^4)}{(t_a - t_s)} \tag{30}$$

where:

E_{miss} = effective surface emittance (includes ambient emittance) and

0.1713×10^{-8} = Stefan-Boltzman Constant (Btu/(h·ft²·R⁴)).

7.4.9 *Overall Coefficient*—Once the radiation and convection coefficients are determined for the specific case under investigation, the overall coefficient is determined by adding the two coefficients together.

$$h = h_{cv} + h_{rad} \tag{31}$$

8. Computer Programs

8.1 General:

8.1.1 The computer programs are written in Basic Fortran in accordance with ANSI X3.9.

NOTE 5—Identical versions of these computer programs have been successfully compiled and run on two processors. Only minor modifications necessary for conformance to the resident operating system were required for operation.

8.1.2 Each program consists of a main program and several subroutines. Other subroutines may be added to make the program more applicable to the specific problems of individual users.

8.1.3 The programs as presented call for the use of an interactive terminal connected in real-time to a computer. The computer controls the terminal interactively with program-generated instructions and questions transmitted to the terminal. Alternatively a second device could be used for display or printing of computer messages. The final report can be displayed or printed on the message destination device or may be directed to a line printer or other hard copy unit. This is the usual device used for the final report when a cathode ray tube is used as the input terminal.

TABLE 1 Shape Factors—Convection Equations

Shape and Condition	Value of C
Horizontal cylinders	1.016
Longer vertical cylinders	1.235
Vertical Plates	1.394
Horizontal plates, warmer than air, facing upward	1.79
Horizontal plates, warmer than air, facing downward	0.89
Horizontal plates, cooler than air, facing upward	0.89
Horizontal plates, cooler than air, facing downward	1.79

TABLE 2 Regression Analysis of Sample Data for Examples 1 to 4

Insulation Type	Functional Relationship Employed	Coefficients and Constants					Correlation Coefficient	F value	Standard Error of Estimates
		a	b	c	TL	TU			
Type 1 (Fig. 11)	$k = a + bt + ct^2$	0.400	0.105×10^{-3}	0.286×10^{-6}	0.999	550	0.0049
Type 2 (Fig. 10)	$\ln k = a + bt$	-1.62	0.213×10^{-2}	0.999	2130	0.0145
Type 3 (Fig. 12)	$k = a_1 + b_1t; t \leq TL$	0.201	0.39×10^{-3}	...	-25	...	0.997	148	0.00165
	$k = a_2 + b_2t; TL < t < TU$	0.182	-0.39×10^{-3}	...	-25	50	0.997	187	0.00094
	$k = a_3 + b_3t; t \geq TU$	0.141	0.37×10^{-3}	50	0.993	69.3	0.00320

8.2 Functional Description of Program— The flow charts, shown in Figs. 5 and 6 are a schematic representation of the operational procedures of the respective programs. They show

that logic paths for reading data, obtaining actual system dimensions, calculating and recalculating system thermal resistances and temperatures, relaxing the successive errors in

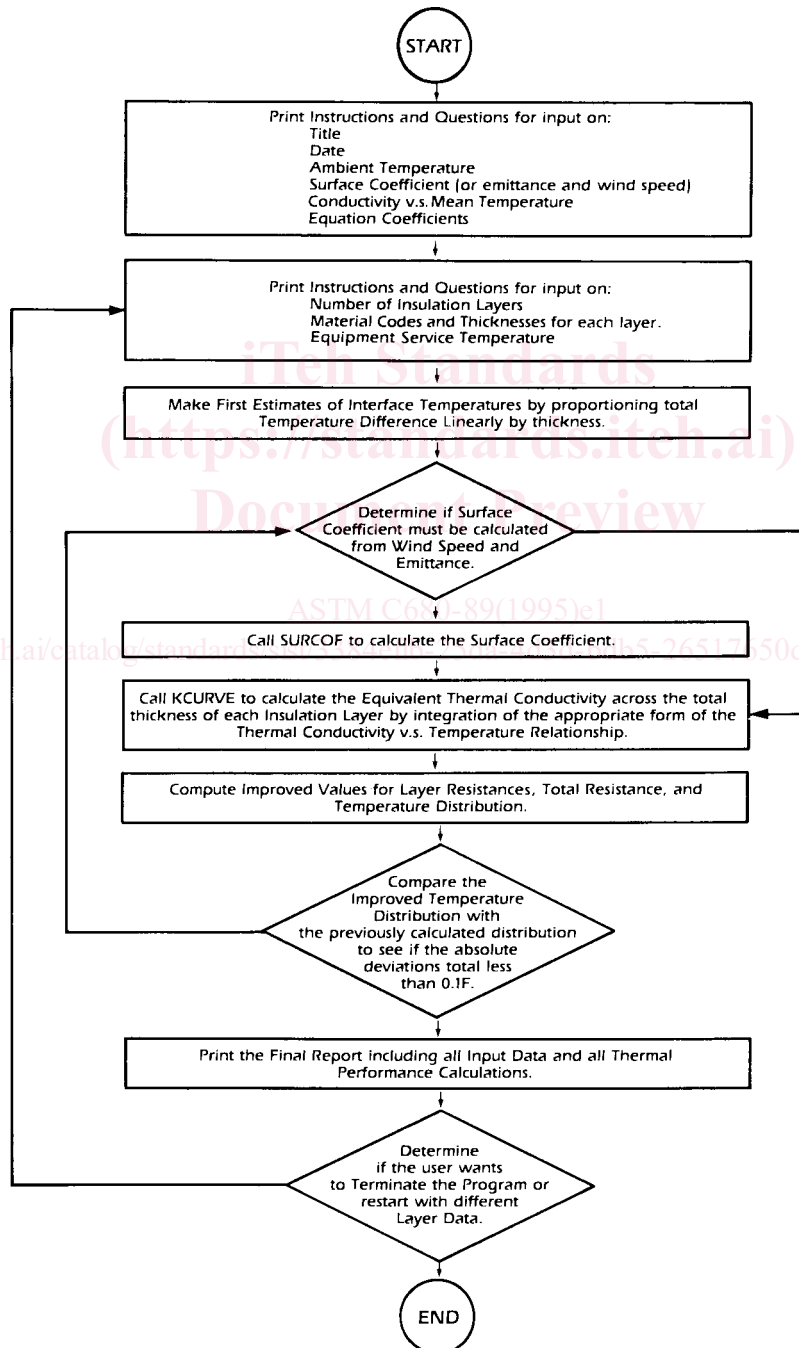

FIG. 5 Flow Diagram of the Computer Program C 680E for Insulated Equipment Systems

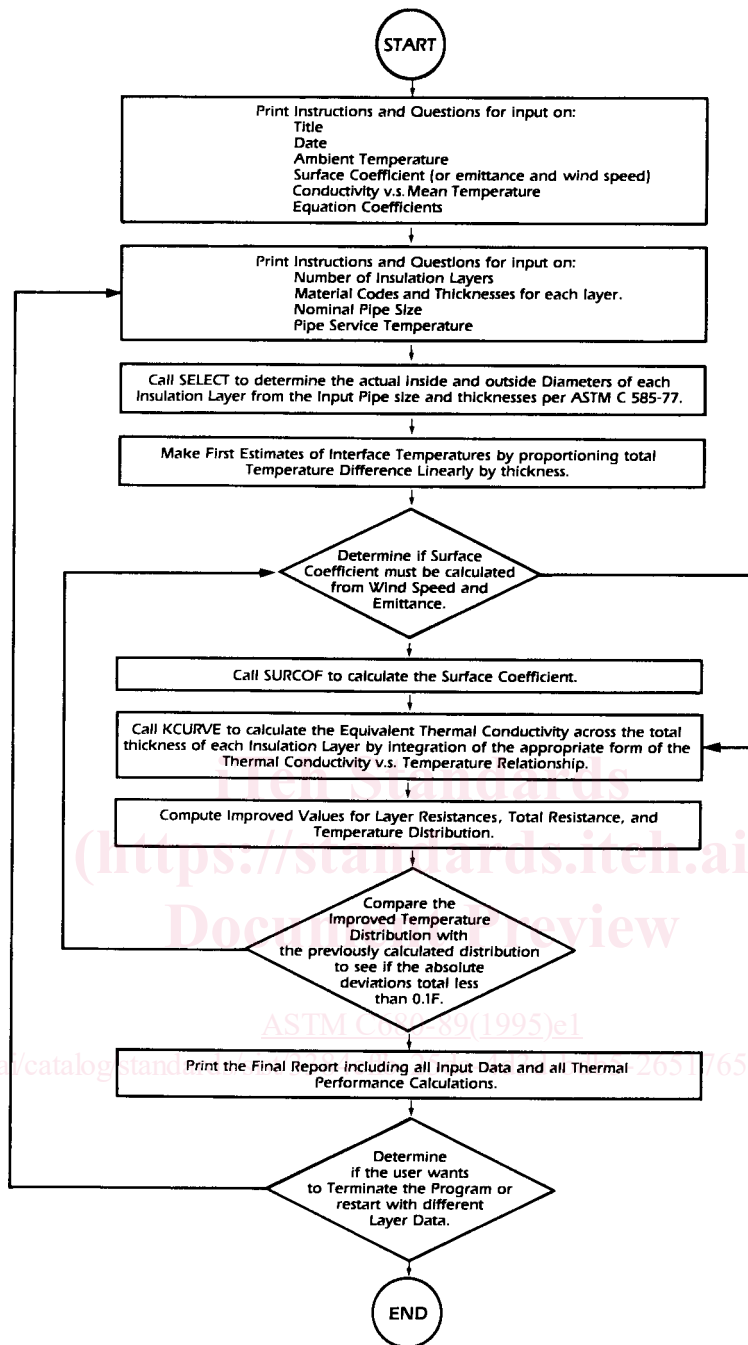

FIG. 6 Flow Diagram of Computer Program C 680P for Insulated Piping Systems

the temperature to within 0.1° of the temperature, calculating heat loss or gain for the system, and printing the parameters and solution in tabular form. The flow chart symbols are in accordance with ANSI X3.5.

8.3 *Computer Program Variable Description*—The description of all variables used in the programs are given in the listing of each program as comments. The listings of the mainline programs and the applicable subroutines are shown in Fig. 7 Fig. 8 Fig. 9.

8.4 *Program Operation:*

8.4.1 Logon procedures and any executive program for execution of this program must be followed as needed.

8.4.2 The input for the thermal conductivity versus mean temperature parameters is obtained as described in 7.3. (See the thermal curves depicted in Figs. 10-12.) The type code determines the thermal conductivity versus temperature relationship applying to the insulation. The same type code may be used for more than one insulation. As presented, the program will operate on the three functional relationships:

```

C LAST REVISION MADE 8/30/83 C680 1
C C680E COMPUTER PROGRAM C680 2
C THIS PROGRAM COMPUTES THE THERMAL PERFORMANCE OF A MULTI- C680 3
C LAYERED EQUIPMENT INSULATION SYSTEM. HEAT TRANSFER EQUATIONS ARE C680 4
C TAKEN FROM MACADAMS: HEAT TRANSFER. THE PROGRAM IS INTENDED FOR C680 5
C USE ON AN INTERACTIVE TERMINAL CONTROLLED BY A TIME-SHARE C680 6
C COMPUTER FOR INFORMATION INPUT. C680 7
C UP TO 7 LAYERS OF INSULATION MAY BE SPECIFIED FOR THE C680 8
C INSULATION SYSTEM BEING ANALYZED. C680 9
C TEN DIFFERENT INSULATION MATERIALS MAY BE SPECIFIED WITH C680 10
C DIFFERENT K-MEAN TEMPERATURE RELATIONSHIPS. PARAMETERS FOR THESE C680 11
C CURVES ARE USER-SUPPLIED WITH NO DEFAULT NUMBERS SUPPLIED BY THE C680 12
C PROGRAM. GROSS CHECKS ARE MADE OF THE REASONABLENESS OF THESE C680 13
C CURVES COMPARED TO TYPICAL INSULATION MATERIALS. CORRECTED VALUES C680 14
C MAY BE ENTERED FOLLOWING AN ERROR MESSAGE. C680 15
C THE SURFACE COEFFICIENT MAY BE INPUT OR THE SURFACE C680 16
C EMITTANCE AND WIND SPEED MAY BE GIVEN, WHICH WILL CAUSE THE C680 17
C SURFACE COEFFICIENT TO BE CALCULATED. C680 18
C C680 19
C VARIABLES USED IN THE MAINLINE PART OF THIS PROGRAM- C680 20
C C680 21
C DATE = DATE C680 22
C EMISS = SURFACE EMITTANCE OF THE INSULATION SYSTEM. C680 23
C ERR = ERROR SIGNAL RETURNED TO THE MAINLINE PROGRAM FOR C680 24
C AN ILLEGAL ENTRY IN THE THICKNESS SCHEDULE. C680 25
C I = INDEX VARIABLE. C680 26
C INSIZ(I) = NOMINAL INSULATION SIZE OF LAYER I. C680 27
C INSK(I,J) = INSULATION K-CURVE PARAMETER ARRAY. C680 28
C IP = SELECT CODE FOR PRINTER USED FOR REPORT OUTPUT. C680 29
C IR = SELECT CODE FOR TERMINAL USED FOR DATA INPUT. C680 30
C IW = SELECT CODE FOR TERMINAL DISPLAYING INPUT C680 31
C DIRECTIONS. C680 32
C K(I) = THERMAL CONDUCTIVITY OF LAYER I, BTU. IN. /HR. SF. F. C680 33
C M = TEMPORARY INPUT VARIABLE USED FOR MATERIAL CODE. C680 34
C MAT(I) = MATERIAL CODE OF LAYER I. C680 35
C NFORM = INDEX DEFINING SHAPE: C680 36
C 1 = CYLINDRICAL C680 37
C 2 = FLAT. C680 38
C NLayer = NUMBER OF INSULATION LAYERS. C680 39
C NOR = ORIENTATION PARAMETER OF HEAT FLOW DIRECTION AT C680 40
C SURFACE. C680 41
C 1 = HORIZONTAL HEAT FLOW (VERTICAL SURFACE) C680 42
C 2 = HEAT FLOW DOWN. C680 43
C 3 = HEAT FLOW UP. C680 44
C Q = RATE OF HEAT FLOW THROUGH THE INSULATION SYSTEM, C680 45
C BTU. /HR. SF. C680 46
C R(I) = THERMAL RESISTANCE OF LAYER I, HR. SF. F./BTU. C680 47
C RS = THERMAL RESISTANCE OF SURFACE, HR. SF. F./BTU. C680 48
C Rsum = THERMAL RESISTANCE OF TOTAL SYSTEM, HR. SF. F./BTU. C680 49
C SURF = THERMAL SURFACE COEFFICIENT, BTU. /HR. SF. F. C680 50
C SURFC = COMPUTED SURFACE COEFFICIENT, BTU. /HR. SF. F. C680 51
C T(I) = INNER TEMPERATURE OF LAYER I, F. THE OUTER C680 52
C TEMPERATURE OF LAYER I IS THE INNER TEMPERATURE C680 53
C OF THE NEXT LAYER. C680 54

```

FIG. 7 Computer Listing—Program C 680E—Thermal Performance of Multilayered Flat Insulation Systems

Type Code	Functional Relationship
1	$k = a + bt + ct^2$ where a , b , and c are constants.
2	$k = e^{a+bt}$ where a and b are constants and e is the base of the natural logarithm
3	$k = a_1 + b_1 t; t < TL$ $k = a_2 + b_2 t; TL < t < TU$ $k = a_3 + b_3 t; t > TU$ $a_1, a_2, a_3, b_1, b_2, b_3$ are constants. TL and TU are, respectively, the lower and upper inflection points of an S-shaped curve.

Additional or different relationships may be programmed but require modifications to the program.

8.4.3 For multiple number entry in a free field format, all numbers must be separated by commas.

9. Illustration of Examples

9.1 General:

9.1.1 Four examples are presented to illustrate the utility of the program in calculating heat loss or gain and surface temperature. Most practical insulation design problems implicitly or explicitly call for such calculations. Three insulating materials, having equations forms for Types 1, 2, and 3, are considered. The fourth example illustrates a combination of these three materials.

NOTE 6—The curves contained herein are for illustration purposes only and not intended to reflect any actual product currently being produced.

ASTM C 680

C	TAMB	= AMBIENT AIR TEMPERATURE, F.	C680 55
C	TDEL	= TEMPERATURE DIFFERENCE BETWEEN SURFACE AND	C680 56
C		AMBIENT TEMPERATURES, F.	C680 57
C	THK(I)	= NOMINAL THICKNESS OF INSULATION LAYER I, INCHES.	C680 58
C	THKTOT	= TOTAL THICKNESS OF INSULATION SYSTEM, INCHES.	C680 59
C	TINT	= INTERMEDIATE LAYER TEMPERATURE	C680 60
C	TITLE	= TITLE OF THE ANALYSIS.	C680 61
C	TL	= LOWER TEMPERATURE BOUNDARY FOR MATERIAL CODE 3.	C680 62
C	TS	= SURFACE TEMPERATURE OF THE INSULATION SYSTEM, F.	C680 63
C	TSUM	= TEST CRITERION FOR THERMAL STABILITY.	C680 64
C	TU	= UPPER TEMPERATURE BOUNDARY FOR MATERIAL CODE 3.	C680 65
C	WIND	= WIND VELOCITY, MILES PER HOUR.	C680 66
C	XK1	= CALCULATED THERMAL CONDUCTIVITY AT 100F.	C680 67
C	XK3	= CALCULATED THERMAL CONDUCTIVITY AT 300F.	C680 68
C	XK6	= CALCULATED THERMAL CONDUCTIVITY AT 600F.	C680 69
C			C680 70
0001		DIMENSION TITLE(15),DATE(15)	C680 71
0002		DIMENSION THK(7)	C680 72
0003		DIMENSION T(8),R(7),MAT(7)	C680 73
0004		REAL K(7),INSK(10,9)	C680 74
C			C680 75
C		THE FOLLOWING 3 COMMANDS DEFINE THE SELECT CODES FOR	C680 76
C		THE TERMINALS USED FOR INPUT AND INSTRUCTION DISPLAY,	C680 77
C		AND THE PRINTER USED FOR SUMMARY REPORT OUTPUT. CONTACT	C680 78
C		YOUR COMPUTER CENTER FOR EXACT FORMAT.	C680 79
C			C680 80
0005	IR=7		C680 81
0006	IW=7		C680 82
0007	IP=6		C680 83
C			C680 84
0008	DO 11 I=1,10		C680 85
0009	DO 10 J=1,9		C680 86
0010	INSK(I,J)=0		C680 87
0011	10 CONTINUE		C680 88
0012	11 CONTINUE		C680 89
C			C680 90
0013	WRITE(IW,20)		C680 91
0014	20 FORMAT(' ASTM C-680 RECOMMENDED PRACTICE FOR THE DETERMINATION OF		C680 92
	*HEAT FLOW AND SURFACE** TEMPERATURES OF MULTIPLE-LAYERED EQUIPMENT		C680 93
	*T INSULATION SYSTEM FOR AN INTERACTIVE** INPUT/OUTPUT COMPUTER TEC		C680 94
	*RMINAL **)		C680 95
C			C680 96
0015	WRITE(IW,30)		C680 97
0016	30 FORMAT(' ENTER TITLE - 60 CHARACTER LIMIT')		C680 98
0017	READ(IR,31)TITLE		C680 99
0018	31 FORMAT(15A4)		C680 100
C			C680 101
0019	WRITE(IW,40)		C680 102
0020	40 FORMAT(' ENTER DATE - ANY FORMAT')		C680 103
0021	READ(IR,41)DATE		C680 104
0022	41 FORMAT(15A4)		C680 105
C			C680 106
0023	WRITE(IW,50)		C680 107
0024	50 FORMAT(' ENTER AMBIENT TEMPERATURE, F')		C680 108

FIG. 7 (continued)

9.1.2 Sample data relating thermal conductivity to mean temperature data for the three insulating materials are shown in Figs. 10-12. Least-square estimates of the regression curve for each sample data set produced a satisfactory fit to one of the program's functional types. The information in Table 2 was obtained from the regression analysis (least-squares fit) on each material.

9.2 Example 1:

9.2.1 Consider application of a Type 2 insulation to the flat vertical surfaces of a piece of hot equipment. The operating temperatures is 450°F (232°C). The equipment is located out-doors in an area where the winter design ambient tempera-

ture is 10°F (-12°C). Determine the insulation thickness required to maintain the heat losses below 35 Btu/h-ft² (110 W/m²).

9.2.2 Assuming the system faces virtually blackbody surroundings at the design ambient temperature, the surface coefficient may be obtained from the *ASHRAE Handbook of Fundamentals (2)*. The value given for a nonreflective surface in a 15-mph (6.7-m/s) wind (winter) is 6.00 Btu/h-ft²·°F (34 W/m²·K).

9.2.3 From Table 2 for the material designated as Type Code 2, the two coefficients required for the equation are $a = -1.62$ and $b = 0.00213$.

```

0025      READ(IR,*)TAMB                                C680 109
      C                                                C680 110
0026      EMISS=-1.0                                  C680 111
0027      WRITE(IW,60)                                C680 112
0028 60     FORMAT(' TYPICAL SURFACE COEFFICIENT IS 1.65. '// IF COEFFICIENT IS C680 113
      * TO BE CALCULATED FROM EMITTANCE AND WIND SPEED ENTER 0'// OTHERWIC680 114
      *SE ENTER SURFACE COEFFICIENT TO BE USED. ')      C680 115
0029      READ(IR,*)SURF                                C680 116
0030      IF(SURF.GT.0.0) GO TO 70                     C680 117
      C                                                C680 118
0032      WRITE(IW,61)                                  C680 119
0033 61     FORMAT(' TYPICAL EMITTANCE IS 0.9. '// TYPICAL WIND SPEED IS 0 MPH. C680 120
      *'// ENTER EMITTANCE, WIND SPEED, AND HEAT FLOW DIRECTION PARAMETERC680 121
      *'//      1 FOR HORIZONTAL HEAT FLOW (VERTICAL SURFACE)'//      2 FOR C680 122
      *R HEAT FLOW DOWN'//      3 FOR HEAT FLOW UP. '//      C680 123
0034      READ(IR,*)EMISS,WIND,NOR                     C680 124
      C                                                C680 125
0035 70     WRITE(IW,71)                                C680 126
0036 71     FORMAT(' UP TO 10 THERMAL CONDUCTIVITY VS. MEAN TEMPERATURE EQUATIC680 127
      *ONS MAY BE USED. '// THEY ARE OF 3 TYPES. THE TYPES ARE: '//      C680 128
      *' MATERIAL CODE 1 - K = A + B * T + C * T**2'//      C680 129
      *' MATERIAL CODE 2 - K = EXP( A + B * T )'//      C680 130
0037      WRITE(IW,72)                                  C680 131
0038 72     FORMAT(5X, 'MATERIAL CODE 3 - K = A1 + B1 * T, FOR      T < TL'// C680 132
      *'      K = A2 + B2 * T, FOR TL < T < TU'//      C680 133
      *'      K = A3 + B3 * T, FOR TU < T'// WHERE A, BC680 134
      *, AND C ARE THE COEFFICIENTS OF THE EQUATIONS, AND T IS THE MEAN' C680 135
      *' TEMPERATURE. ')      C680 136
      C                                                C680 137
0039      I=0                                           C680 138
0040 73     I=I+1                                       C680 139
      C                                                C680 140
0041      WRITE(IW,74)I                                 C680 141
0042 74     FORMAT(' ENTER MATERIAL TYPE CODE (OR 0 IF ALL ENTERED) FOR INSULAC680 142
      *TION NO. ',I3)      C680 143
0043 75     CONTINUE                                    C680 144
0044      READ(IR,*)M                                    C680 145
0045      IF (M-1) 130,80,90                            C680 146
      C                                                C680 147
0046 80     WRITE(IW,81)                                C680 148
0047      INSK(I,1)=1.0                                  C680 149
0048 81     FORMAT(' ENTER A, B, C FOR MATERIAL TYPE 1. ') C680 150
0049      READ(IR,*)INSK(I,2),INSK(I,3),INSK(I,4)      C680 151
0050      XK3=INSK(I,2)+INSK(I,3)*300.+INSK(I,4)*300.**2 C680 152
0051      XK6=INSK(I,2)+INSK(I,3)*600.+INSK(I,4)*600.**2 C680 153
0052      IF(ABS((XK3-.46)/.46).GT.0.15) GO TO 82      C680 154
0054      IF(ABS((XK6-.57)/.57).LT.0.15) GO TO 73     C680 155
0056 82     WRITE(IW,83)XK3,XK6                        C680 156
0057 83     FORMAT(' K-CURVE IS NOT IN NORMAL RANGE'//      K AT 300F='F6.3/, 'C680 157
      *      K AT 600F =',F6.3/, ' ENTER 1 TO RE-ENTER K DATA, OTHERWISE 0' C680 158
      *)      C680 159
0058      READ(IR,*)NN                                  C680 160
0059      IF(NN.EQ.1) GO TO 80                          C680 161
      C                                                C680 162

```

FIG. 7 (continued)

9.2.4 From past experience, it is estimated that the required thicknesses will fall in the range from 4.0 to 5.0 in. (101 to 127 mm). This range will be covered in increments of 1/2 in. (3 mm).

9.2.5 The resulting programing and analysis is given in Fig. 13 where 4.5 in. (114 mm) is the least thickness to maintain heat loss below 35 Btu/h-ft² (110 W/m²).

9.3 Example 2:

9.3.1 Determine the minimum nominal thickness of Type 1 pipe insulation required to maintain the surface temperature of a horizontal 3-in. (76-mm) iron pipe below 130°F (54°C). Consider a pipe temperature of 800°F (427°C). The ambient temperature is 80°F (26°C).

9.3.2 Assuming the piping is located in a large room with surrounding surfaces at ambient temperature and that the emissivity of the system is not significantly different from that of bare steel pipe (0.9), the surface coefficient could be estimated from the *ASHRAE Handbook of Fundamentals (2)*. Because the thicknesses to be chosen will provide a surface temperature about 50°F (28°C) above the 80°F (26°C) ambient, the 50° column is entered. The system diameter (insulation size) is not known since it will depend on the insulation thickness. For the first calculation, and the estimated insulation diameter, 9 in. (229 mm), 1.76 Btu/(h-ft²·°F) (10 W/m²·K), will be used. The thicknesses chosen as a result of the first calculation will provide a basis for reestimating the surface