



**iTeh STANDARD PREVIEW**  
**(standards.iteh.ai)**

SIST ISO 11423-2:1998

<https://standards.iteh.ai/catalog/standards/sist/b3688d87-1816-4757-90b6-3677d0469f0/sist-iso-11423-2-1998>

INTERNATIONAL  
STANDARD

ISO  
11423-2

First edition  
1997-06-01

---

---

**Water quality — Determination of benzene  
and some derivatives —**

**Part 2:  
Method using extraction and gas  
chromatography**

iTeh STANDARD PREVIEW  
(standards.iteh.ai)

*Qualité de l'eau — Détermination du benzène et de certains dérivés  
benzéniques —*

*Partie 2: Méthode par extraction et chromatographie en phase gazeuse*

[SIST ISO 11423-2:1998](https://standards.iteh.ai/catalog/standards/sist/b3688d87-1816-4757-90b6-3677d0469f0/sist-iso-11423-2-1998)

<https://standards.iteh.ai/catalog/standards/sist/b3688d87-1816-4757-90b6-3677d0469f0/sist-iso-11423-2-1998>



Reference number  
ISO 11423-2:1997(E)

## ISO 11423-2:1997(E)

## Foreword

ISO (the International Organization for Standardization) is a worldwide federation of national standards bodies (ISO member bodies). The work of preparing International Standards is normally carried out through ISO technical committees. Each member body interested in a subject for which a technical committee has been established has the right to be represented on that committee. International organizations, governmental and non-governmental, in liaison with ISO, also take part in the work. ISO collaborates closely with the International Electrotechnical Commission (IEC) on all matters of electrotechnical standardization.

Draft International Standards adopted by the technical committees are circulated to the member bodies for voting. Publication as an International Standard requires approval by at least 75 % of the member bodies casting a vote.

International Standard ISO 11423-2 was prepared by Technical Committee ISO/TC 147, *Water quality*, Subcommittee SC 2, *Physical, chemical, biochemical methods*.

ISO 11423 consists of the following parts, under the general title *Water quality — Determination of benzene and some derivatives*:

- Part 1: *Head-space gas chromatographic method*
- Part 2: *Method using extraction and gas chromatography*

Annexes A, B and C of this part of ISO 11423 are for information only.

<https://standards.iteh.ai/catalog/standards/sist/b3688d87-1816-4757-90b6-3677d0469f10/sist-iso-11423-2-1998>

© ISO 1997

All rights reserved. Unless otherwise specified, no part of this publication may be reproduced or utilized in any form or by any means, electronic or mechanical, including photocopying and microfilm, without permission in writing from the publisher.

International Organization for Standardization  
Case postale 56 • CH-1211 Genève 20 • Switzerland  
Internet [central@iso.ch](mailto:central@iso.ch)  
X.400 c=ch; a=400net; p=iso; o=isocs; s=central

Printed in Switzerland

## Introduction

This part of ISO 11423 describes an extraction method of sample treatment followed by the gas chromatography for the determination of benzene and derivatives in water.

For a head-space procedure see ISO 11423-1.

Which of these methods is applicable in a given case depends for instance on the type of sample to be analysed and the instruments available to the analyst. The method used is then described in the test report.

## iTeh STANDARD PREVIEW (standards.iteh.ai)

SIST ISO 11423-2:1998

<https://standards.iteh.ai/catalog/standards/sist/b3688d87-1816-4757-90b6-3677d0469f0/sist-iso-11423-2-1998>

**iTeh STANDARD PREVIEW**  
This page intentionally left blank  
**(standards.iteh.ai)**

SIST ISO 11423-2:1998

<https://standards.iteh.ai/catalog/standards/sist/b3688d87-1816-4757-90b6-3677d0469f0/sist-iso-11423-2-1998>

# Water quality — Determination of benzene and some derivatives —

## Part 2:

## Method using extraction and gas chromatography

### 1 Scope

The method described is applicable to the determination of benzene, methylbenzene (toluene), dimethylbenzenes (xylenes) and ethylbenzene (abbreviated hereafter to BTX) in water and waste water in concentrations above 5 µg/l. High concentrations may be determined by diluting the extract.

A number of further derivatives and nonpolar compounds with similar boiling points may also be determined by this method. The applicability of the methods should be verified in these cases for the particular water sample.

**ITeH STANDARD PREVIEW**  
(standards.iteh.ai)

### 2 Principle

The unfiltered sample is extracted with a nonpolar solvent (e.g. pentane) and the extract is analysed by gas chromatography. Benzene and its derivatives are separated by injection on two capillary columns with stationary phases of different polarity (e.g. by simultaneous splitting) and determined using a suitable detector (for identification of compounds see 7.4).

### 3 Interferences

Loss of BTX may occur during sampling, transport, storage and preparation of samples due to evaporation and stripping. Other volatile compounds in the ambient air may contaminate water samples and water used for blank tests, leading to high limits of detection and high blank values, respectively.

To avoid errors due to sorption or desorption of constituents, samples should not come into contact with plastics materials.

Surfactants, emulsifiers and higher contents of polar solvents such as propanone or methanol will impair the extraction procedure. Suspended solids affect extraction and recovery.

The presence of a second liquid phase (e.g. mineral oil, volatile organic halogenated hydrocarbons, emulsified grease and waxes) will affect sampling, sample preparation and extraction. Only the content of the aqueous phase would be determined; it is possible, however, to determine the content of the second liquid phase separately. If this is done, it shall be stated in the test report.

Specific problems in the gas chromatographic system shall be handled according to the manufacturer's instructions.

The determination may be hindered by superposition of other hydrocarbons, for instance mineral oil constituents, which may also result in column overload.

If the results from the two different columns differ significantly, repeat the analysis with another separating phase or a specific detector.

## 4 Apparatus

Keep all precleaned bottles and vials in an upside-down position for 1 h at 150 °C in a ventilated drying oven before use. After this procedure, protect them from contamination, for instance by covering them with aluminium foil while they cool and closing them as soon as they are cool.

**4.1 Conical-shoulder bottles**, nominal capacity e.g. 2 l, of non-actinic glass with tight stopper or PTFE- or aluminium-lined cap.

**4.2 Magnetic stirrer** with PTFE-coated bars.

**4.3 Pipettes**, capacity e.g. 1 ml, 2 ml, 5 ml, 10 ml, 25 ml and 50 ml, made of glass.

**4.4 Gas washing-bottle attachment** with ground glass cone and sintered disc.

**4.5 One-mark pipette**.

**4.6 Graduated flasks**, capacity 100 ml, 250 ml and 1 000 ml.

**4.7 Gas chromatograph** with glass insert assembly and flame ionization detector (FID) supplied with gases as specified by the manufacturer.

**4.8 Capillary columns** for gas chromatography (see annex B).

NOTE — If alkanes with retention times identical with BTX are expected, the Kovacs indices are useful for the choice of the columns used.

**4.9 Injection syringes**, capacity 10 µl, 50 µl and 100 µl.

**4.10 Microseparator** (see figure 1).

**4.11 Quartz wool**, cleaned with pentane and dried.

## 5 Reagents

Use only reagents of recognized analytical grade and only water complying with 5.1.

### 5.1 Water for dilutions and the reagent blank.

The BTX content of the water shall be as low as possible. In case of contamination, the water may be treated as follows:

Fill the water into conical-shoulder bottles (4.1), place a glass filter near the bottom of the flask, heat the water to approximately 60 °C. Pass a stream of nitrogen (approximately 180 ml/min) through the water for 1 h, then allow the water to cool to room temperature while still passing nitrogen through it. Close the bottle tightly and store in the dark.



Dimensions in millimetres

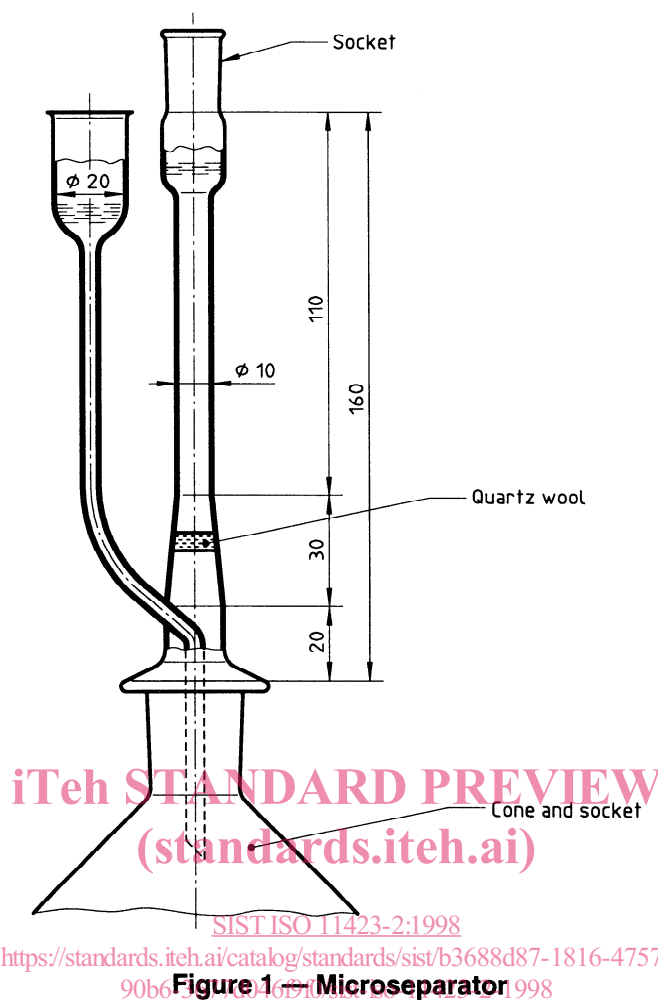

Figure 1 — Microseparator

If necessary, pass nitrogen through the water immediately before use.

Check the quality of the water before and after treatment. If contamination is still detected, use another gas for purification, or purify the gas used.

**5.2 Operating gases** for the gas chromatography system (nitrogen, helium, hydrogen, synthetic air) according to the manufacturer's instructions.

**5.3 Pentane**,  $C_5H_{12}$ , checked for absence of BTX by gas chromatography.

Distill contaminated pentane on a high performance column, with the purity of the distillate fractions being checked; it may be necessary to repeat distillation.

**5.4 Calibration standard substances**, each of highest purity.

Benzene	$C_6H_6$
Methylbenzene (toluene)	$C_7H_8$
1,2-Dimethylbenzene ( <i>o</i> -xylene)	$C_8H_{10}$
1,3-Dimethylbenzene ( <i>m</i> -xylene)	$C_8H_{10}$
1,4-Dimethylbenzene ( <i>p</i> -xylene)	$C_8H_{10}$
Ethylbenzene	$C_8H_{10}$

### 5.5 Propan-2-one (acetone), CH<sub>3</sub>COCH<sub>3</sub>, as solution aid.

Determine its reagent blank according to 7.3.

### 5.6 Internal standard, e.g. deuteromethylbenzene (toluene-*d*<sub>8</sub>).

## 6 Sampling and sample preparation

Collect the samples in non-actinic glass conical-shoulder bottles (4.1). Use separate sets of containers for samples of waters with different levels of BTX content.

Take care that the temperature of the samples is not raised during transport.

If possible, start the extraction within 2 days after collection of the sample. If the sample has to be stored longer than 2 days, keep it in the conical-shoulder flasks and store it at 4 °C in the dark.

It is preferable to perform the extraction procedure as soon as possible, as the extracts are more stable than the samples.

Automatic samplers are only suitable if they are composed of glass and metals only, with as little possible plastics materials, and if they are not used under reduced pressure. Cool the sampling container to about 4 °C and use a glass tube immersed in the sample container to transfer sample subquantities, to avoid losses.

## iTeh STANDARD PREVIEW (standards.iteh.ai)

## 7 Procedure

### 7.1 Extraction

SIST ISO 11423-2:1998

The extraction ratios depend on the expected BTX mass concentration; recommended ratios are given in table 1.

**Table 1 — Recommended ratios**

Volume ratio organic phase : sample	Expected concentration range
1:100	1 to 10 µg/l
10:100	10 to 100 µg/l
50:50	100 to 1 000 µg/l
100:10	1 to 10 mg/l

Higher BTX concentrations may be determined by dilution of the extract.

Cool the sample to approximately 4 °C, transfer to a graduated flask with graduated neck, add the internal standard (5.6) if applicable, and cover with the appropriate volume of pentane (5.3).

It is also possible to weigh the sampling bottle prior to sampling and after sampling to determine the volume, and add the pentane directly to the sampling bottle.

Extract by stirring with the magnetic stirrer or on a mechanical shaker or by shaking manually for 5 min.

To avoid losses through evaporation, it is recommended to cool the flask with ice during extraction.

If less than half of the original volume of pentane is recovered, repeat the extraction with a different phase ratio (larger volume of pentane).

For small volumes of organic phase, use the microseparator (4.11) with the quartz wool plug to improve separation. Add water into the leg of the separator to force the organic phase into the riser tube. The quartz wool helps phase separation and keeps back suspended matter as well.

After completion of the phase separation and recovery of a sufficient volume of pentane, analyse an aliquot of the extract using the gas chromatograph as soon as possible.

If an immediate analysis is not possible, transfer to a sample vial and store in the dark, preferably at 4 °C. Extracts are stable for about 20 days.

## 7.2 Gas chromatography

Adjust the gas chromatograph according to the manufacturer's instructions.

To ensure identification of the respective compounds, use at least two capillary columns with different stationary phases and different polarities. It is advantageous to have both capillary columns mounted on one injector for simultaneous sample injection.

Glass or silica columns, coated with silicone or methyl silicone separating phases cross-linked (chemically bonded) with variable phenyl content, may be used (see annex B).

For detection, use a flame ionization detector (FID) with linear operating characteristics over the measuring range. It may be necessary to use a selective detector (e.g. mass spectrometer, photo-ionization detector) to improve compound identification.

Use of two columns with differing polarities does not completely exclude peak overlap. If the results from the two columns used differ, peak overlap may be the reason; in this case the lower value is usually more accurate than the higher one.

<https://standards.iteh.ai/catalog/standards/sist/b3688d87-1816-4757-90b6-3677d0469f0/sist-iso-11423-2-1998>

## 7.3 Blank measurement

Benzene is present ubiquitously in trace levels. For this reason, perform blank determinations using water (5.1) prior to and during a series of analyses. Blank measurements should include all steps of the analytical procedure from sampling to the evaluation of the gas chromatogram. If blank values are unusually high (more than 10 % of the lowest measured values), every step in the procedure shall be checked in order to find the reason for these high blank values. Blank values should be reduced as much as possible by various procedures such as elimination of contamination of the sample by ambient air and checking of the gas chromatographic or integration parameters.

If sample concentrations are close to the limit of detection, however, blank values higher than 10 % of the lowest measured value shall be tolerated.

The blank value shall be deducted only if the standard deviation of the blank value does not significantly exceed the standard deviation of the calibration function.

## 7.4 Identification of individual compounds

Identify an individual compound by comparing its retention time in the sample with that corresponding in the calibration solutions.

In order to ensure correct identification, the retention times should not differ from one another in a series of analyses by more than  $\pm 0,02$  min, given comparable concentration, or  $\pm 0,02$  % of relative retention times under 2 min when using an internal standard.