



Standard Test Methods for Detention Sliding Door Locking Device Assembly¹

This standard is issued under the fixed designation F 1643; the number immediately following the designation indicates the year of original adoption or, in the case of revision, the year of last revision. A number in parentheses indicates the year of last reapproval. A superscript epsilon (ϵ) indicates an editorial change since the last revision or reapproval.

1. Scope

1.1 These test methods cover the apparatus, procedures, and acceptance conditions for evaluating the normal operational performance and the performance characteristics under assault, smoke, and fire conditions of sliding device assemblies in detention and correctional institutions. These test methods give an indication of the performance characteristics of devices in actual service. Such variables as installation and maintenance conditions are not considered.

1.2 It is the intent of these test methods to help ensure that detention sliding devices perform at or above minimum acceptable levels to control passage to unauthorized or secure areas, to confine inmates and to delay and frustrate escape attempts and resist vandalism. However, these test methods do not address door construction. It is recognized that in order to meet the intent of these test methods, door assemblies shall be compatible with the level of performance required by Test Methods F 1450.

1.3 The values stated in inch-pound units are to be regarded as the standard. The values given in parentheses are for information only.

1.4 *This standard does not purport to address all of the safety concerns, if any, associated with its use. It is the responsibility of the user of this standard to establish appropriate safety and health practices and determine the applicability of regulatory limitations prior to use.*

2. Referenced Documents

2.1 ASTM Standards:

E 152 Methods of Fire Tests of Door Assemblies²

F 1450 Test Methods for Hollow Metal Swinging Door Assemblies for Detention Facilities³

2.2 NFPA Standards:

NFPA101 Life Safety Code⁴

NFPA105 Installation of Smoke Control Door Assemblies⁴

2.3 UL Standard:

UL-1034 Standard for Burglary Resistant Electric Locking Mechanisms⁵

3. Terminology

3.1 Definitions:

3.1.1 *controlled passage, n*—the capability to restrict the unauthorized movement of individuals.

3.1.2 *cover box, n*—the enclosure that contains, secures, and protects all horizontal tracks, cables, tubing, wiring, motors, etc. that support and control the door; the enclosure is continuous across the horizontal door movement and may be continuous across several doors. Also referred to as horizontal mechanism housing.

3.1.3 *deadlocked, adj*—mechanical condition of the locking mechanism which secures against unlocking or unlatching by end pressure, lifting, prying, or other manipulations against the mechanism.

3.1.4 *door guide, n*—horizontal member attached to the wall adjacent to the bottom of the door used to control the bottom of the door.

3.1.5 *hand tools, n*—items permitted for use in disengaging a lock when it fails to disengage either remotely or manually. For example, hand screwdrivers (of various sizes and tip configurations including tips for coverplate security screws), claw hammer, ball peen hammer, chisel, pliers (any common size), and vise grips. These tools are commonly carried in a correctional facility maintenance tool kit.

3.1.6 *leading edge, n*—the end of the door panel which travels across the door opening.

3.1.7 *lock column, n*—the vertical enclosure that contains, secures, and protects the mechanical locking mechanism.

3.1.8 *locked, adj*—the movable panel is held in place by the engagement of the locking bar into the movable panel at the head and foot. Sliding doors must be deadlocked to be secure. A sliding door is not considered locked unless it is also deadlocked.

3.1.9 *receiver, n*—vertical channel that wraps around the leading edge of the door and provides vertical support against

⁵ Available from Underwriters Laboratories, 333 Pfingten Rd., Northbrook, IL 60062.

¹ These test methods are under the jurisdiction of ASTM Committee F-33 on Detention and Correctional Facilities and are the direct responsibility of Subcommittee F33.04 on Operational Systems.

Current edition approved Sept. 10, 1995. Published November 1995.

² Discontinued. See 1994 *Annual Book of ASTM Standards*, Vol 04.07.

³ *Annual Book of ASTM Standards*, Vol 04.07.

⁴ Available from the National Fire Protection Association, Battery March Park, Quincy, MA 02269.

lateral and perpendicular movement of the door in a closed position.

4. Significance and Use

4.1 A major concern for detention and correctional administrative officials is the reliable operation of sliding devices used in their facilities. These test methods aid in assigning a level of physical security and performance to devices for sliding door assemblies.

4.2 These test methods evaluate the resistance of a sliding door assembly to attacks using battering devices, prying devices, smoke, and fire. These test methods also evaluate the performance of a sliding device under simulated operating conditions. These test methods do not provide a measure of the resistance or performance of the device subjected to attack by chemical agents, ballistics, explosives, or other extreme methods of attack. These test methods do not measure the resistance or performance of the device when subjected to environmental elements such as humidity, temperature, rain, snow, or wind carried dust or sand. Where such elements may be a factor the manufacturer should be consulted for proper application.

4.3 The primary purpose of these test methods is to approximate the levels of abuse and operating conditions to which devices are subjected in detention and correctional institutions. The result of these test methods will provide a measure of assurance of protection to the correctional personnel, public, and inmates.

4.4 Preventative maintenance programs shall be provided in accordance with the manufacturer's recommendation to enable sliding device assemblies to function as intended throughout the expected service life.

4.5 These test methods do not measure the performance or cycle life of the local or remote mechanical emergency release mechanism, or both, due to their design variables and low user requirements.

5. Sample Selection, Construction, and Size

5.1 Sample devices shall be representative of the types and styles intended for use in the application of these test methods.

5.2 The manufacturer shall permanently mark the test samples and retain them at the manufacturing facility for future reference. In lieu of test samples, the manufacturer may provide a certified procedure for the construction of tested assemblies.

5.3 If the test assembly is required to be certified by an independent, third party testing and certification agency, any change of components or assembly methods or processes shall be certified in writing by the testing and certification agency. The agency shall have the sole authority to decide the extent and scope of retesting required.

5.4 Test reports shall include complete details and photographs of the test specimen, the testing apparatus, and installation instructions including templates for all items of hardware.

6. Test Methods

6.1 A test sample shall consist of a minimum of one locking device complete with cover box, lock column, receiver, and door guide where these elements are part of a complete locking

device. The test methods that follow consist of independent setups and procedures.

6.2 *Horizontal Impact Test*—Locking devices shall comply with the following:

6.2.1 *Scope*—This test method is designed to evaluate the capability of a detention sliding door locking device to resist repeated impact forces against the side of the door.

6.2.2 *Significance and Use*:

6.2.2.1 This test method is intended to closely simulate a sustained battering ram attack and provide an evaluation of the capability of the locking device to prevent, delay, or frustrate escape or access to unauthorized areas, or both. The test results are intended to aid in assigning a level of physical security to various configurations of detention sliding door locking devices.

6.2.2.2 An impact test of this design performed on a detention sliding device evaluates the impact strength of the device and its components, as well as quality of fabrication techniques.

6.2.3 *Apparatus*:

6.2.3.1 *Test Assembly*—This assembly consists of a test fixture (frame) and impactor apparatus as shown in Fig. 1. Refer to Appendix X1. The device under test and the test door panel are mounted on the test fixture.

6.2.3.2 *Impactor*—The impactor shall consist of a hinged or pivoted system with a mass capable of delivering impacts of 200 ft·lbf (271.2 J) to a sliding panel simulating a door and locking device mounted to a wall. The striking surface of the impactor shall be made from C1010–C1020 carbon steel and have a striking surface area of 4.0 ± 0.04 in.² (25.8 cm²) (see Fig. 2). The weight of the impactor shall be 80 lb (36.3 kg) \pm 1 %.

6.2.4 *Procedure*:

6.2.4.1 Install the locking device on a test fixture that simulates installation of a detention sliding device on a wall. Anchoring method for the device including lock column, receiver jamb, and door guide shall be consistent with manufacturer recommended installation procedures. Using test apparatus described in 6.2.3.1 (Fig. 1), deliver the number of impacts of 200 ft·lbf (271.2 J) as required for grade level being tested. See Table 1 for the number of required impacts. The number of impacts shall be one quarter of the total number of blows required by Table 1, delivered at each corner of the door as shown in Fig. 1.

6.2.5 *Test Termination and Conditions of Acceptance*—The device shall remain locked and controlled passage shall be maintained throughout the testing. Failure of device to remain locked or to control passage shall constitute failure. If the device will not unlock and open by remote or key operation or by use of commonly available hand tools, it shall constitute failure.

6.2.6 *Precision and Bias*—No information is presented about either precision or bias of the horizontal impact test in these test methods since the test result is nonquantitative.

6.3 *Vertical Impact Test*—Sliding device assemblies shall comply with the following:

6.3.1 *Scope*—This test method is designed to evaluate the capability of a detention sliding device assembly to resist

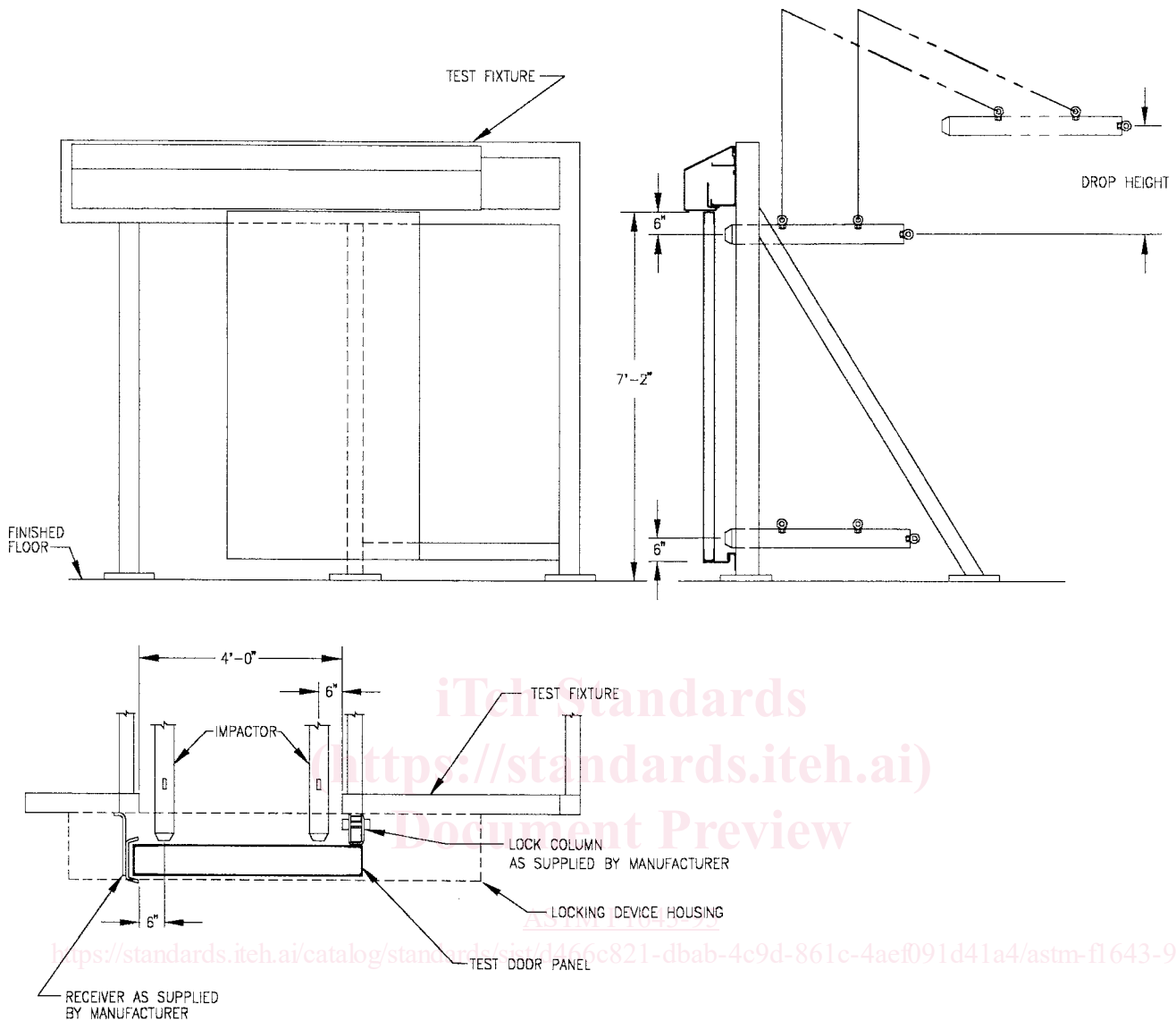

FIG. 1 Test Assembly

repeated impact force.

6.3.2 *Significance and Use*—This test method is intended to simulate the impact caused by lifting the door to the maximum allowed by device clearances and then releasing the door.

6.3.3 *Apparatus*—The test equipment will consist of a mechanism capable of lifting a 300 lb (136 kg) door and applying a controlled vertical force. The device should be able to repeatedly exert a controllable vertical force on the door and then quickly release it to simulate dropping the door. A typical test arrangement is shown in Fig. 3.

6.3.4 *Procedure*—Using the test apparatus described in 6.2.3, the 300 lb (136 kg) door will be locked in the closed position and raised to the extent allowed by the mechanical clearances of the locking device. When the door is at its upper extreme, no more than 50 lbf (222 N) of vertical force will be applied. Then remove the vertical force quickly enough to allow the door to fall of its own weight. Repeat this sequence the number of cycles required by Table 2. During the test, the door will remain locked and maintain controlled passage.

6.3.5 *Test Termination and Conditions of Acceptance*—The door shall maintain controlled passage and remain locked throughout the test. Inability of the sliding device assembly to remain locked and maintain controlled passage throughout the test shall constitute failure. Upon completion of the test sequence, the sliding device will be cycled in its normal mode of operation, open then closed and locked. The sliding device shall achieve physical locking and shall indicate a secure condition when indicators are provided. This cycle shall be repeated a total of five times. Inability of the sliding device to complete any cycle shall constitute failure.

6.3.6 *Precision and Bias*—No information is presented about either precision or bias of the vertical impact test in these test methods since the test result is nonquantitative.

6.4 *Remote Unlocking Force Test:*

6.4.1 *Scope*—This test method covers the capabilities of remotely controlled devices to function under simulated operating conditions while lateral force is applied either perpendicular or parallel to the door face to prohibit device operation.

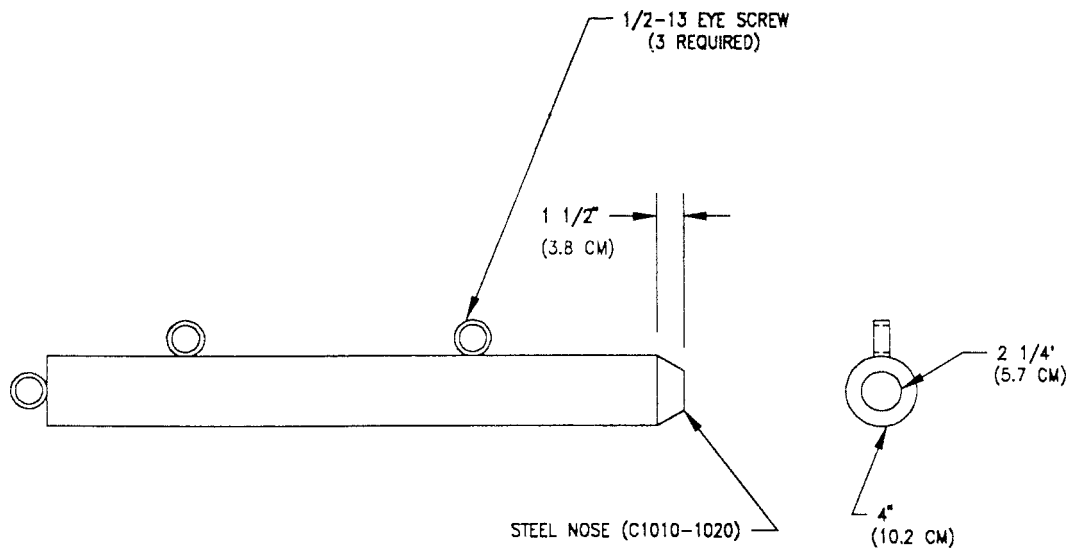

FIG. 2 Steel Impact Ram

TABLE 1 Impact Test Criteria

Security Grade	Number of Impacts	Element of Time ^A
1	600	1.5 h
2	400	1 h

^A Element of time is based on the assumption that sustained manpower can deliver 400 blows of 200 ft-lbf (271.2 J) each in as few as 45 min. Since 400 blows is the number of impacts a Grade 2 device must absorb and still be operable, as described in 6.2.5; it is assumed failure of the Grade 2 device will occur after 60 min. The element of time assigned to the various grades of devices is adjusted to achieve more manageable time periods than actual calculations provide. The element of time is hypothetical.

6.4.2 *Significance and Use*—This test method simulates the remote release (unlocking) of devices while being subjected to either a perpendicular or parallel lateral force directed to stop unlocking operation. A test of this design performed on a sliding device evaluates the operating force characteristics and strength of the device and its components as well as quality of fabrication techniques.

6.4.3 *Apparatus:*

6.4.3.1 The test fixtures shall consist of assemblies suitable for mounting the locking devices and a test door panel. Examples of these fixtures are shown in Fig. 4 and Fig. 5 and shall incorporate the device manufacturer's recommendations for mounting the device.

6.4.3.2 Test apparatus shall consist of loading device, a control panel, and means for monitoring voltage and current supplied to the device. When testing pneumatic devices, air pressure shall also be monitored. For the test load perpendicular to the door, the load shall be 100 lbf (445 N) applied on the center of the door. The test load for parallel load to the door shall be 40 lbf (178 N) applied to the center of the door edge.

6.4.3.3 A means shall be provided to adjust the energy to the device within the parameters specified in 6.4.4.3.

6.4.4 *Procedure:*

6.4.4.1 Mount test device on the test fixture in accordance with the manufacturer's recommended installation instructions.

6.4.4.2 Lubricate the device in accordance with manufacturer's installation instructions.

6.4.4.3 Set the power source to the test device's operator to the minimum value allowed by the manufacturer while main-

taining electrical energy in compliance with Standard UL-1034 when applicable.

6.4.4.4 Verify that the door and the lock are free from binding before applying the load to the door.

6.4.4.5 With the device locked, apply the static load determined in 6.4.3.2 on the centerlines of the door.

6.4.4.6 Unlock the device remotely while maintaining the specified test load.

6.4.4.7 Perform steps 6.4.4.5 and 6.4.4.6 five consecutive times for a perpendicular loaded door and five consecutive times for a parallel loaded door. Each test shall be completed in 15 min.

6.4.5 If the device fails to unlock in 10 s or more in any of the five attempts, this shall constitute failure of the test.

6.4.5.1 If during any of the five attempts, the power consumption exceeds the manufacturer's specifications, this shall constitute failure of the test.

6.4.6 *Precision and Bias*—No information is presented about either precision or bias of the remote unlocking force test in these test methods since the test result is nonquantitative.

6.5 *Operational Force Test:*

6.5.1 *Scope*—This test method is designed to evaluate the ability of the sliding device assembly to be repeatedly stalled during operation. A sustained stall capability of the device is also tested.

6.5.2 *Significance and Use*—This test method is intended to simulate the intentional or accidental stalling of door movement during normal closing operation.

6.5.3 *Apparatus*—The test equipment shall consist of a hand held device capable of measuring and recording a force of 40 lbf (178 N) with an accuracy of $\pm 5\%$.

6.5.4 *Procedure*—Using the test apparatus described in 6.5.3, the following cycle shall be executed:

6.5.4.1 With the door in the open position, operate the sliding device to close the door in the normal manner. When the door is approximately half way closed, manually apply the measuring device to the mid-point of the front edge of the door.

6.5.4.2 Exert sufficient force to stall the door and maintain