

# INTERNATIONAL STANDARD

AMENDMENT 1

Information technology – Generic cabling systems for data centres

(<https://standards.iteh.ai>)  
Document Preview

ISO/IEC 24764:2010/AMD1:2014

<https://standards.iteh.ai/catalog/standards/iso/ba282187-009f-4b30-baff-1a1f5d79e891/iso-iec-24764-2010-amd1-2014>

WITHDRAWN



**THIS PUBLICATION IS COPYRIGHT PROTECTED**  
**Copyright © 2014 ISO/IEC, Geneva, Switzerland**

All rights reserved. Unless otherwise specified, no part of this publication may be reproduced or utilized in any form or by any means, electronic or mechanical, including photocopying and microfilm, without permission in writing from either IEC or IEC's member National Committee in the country of the requester. If you have any questions about ISO/IEC copyright or have an enquiry about obtaining additional rights to this publication, please contact the address below or your local IEC member National Committee for further information.

Droits de reproduction réservés. Sauf indication contraire, aucune partie de cette publication ne peut être reproduite ni utilisée sous quelque forme que ce soit et par aucun procédé, électronique ou mécanique, y compris la photocopie et les microfilms, sans l'accord écrit de l'IEC ou du Comité national de l'IEC du pays du demandeur. Si vous avez des questions sur le copyright de l'ISO/IEC ou si vous désirez obtenir des droits supplémentaires sur cette publication, utilisez les coordonnées ci-après ou contactez le Comité national de l'IEC de votre pays de résidence.

IEC Central Office  
3, rue de Varembe  
CH-1211 Geneva 20  
Switzerland

Tel.: +41 22 919 02 11  
Fax: +41 22 919 03 00  
[info@iec.ch](mailto:info@iec.ch)  
[www.iec.ch](http://www.iec.ch)

#### **About the IEC**

The International Electrotechnical Commission (IEC) is the leading global organization that prepares and publishes International Standards for all electrical, electronic and related technologies.

#### **About IEC publications**

The technical content of IEC publications is kept under constant review by the IEC. Please make sure that you have the latest edition, a corrigenda or an amendment might have been published.

#### **IEC Catalogue - [webstore.iec.ch/catalogue](http://webstore.iec.ch/catalogue)**

The stand-alone application for consulting the entire bibliographical information on IEC International Standards, Technical Specifications, Technical Reports and other documents. Available for PC, Mac OS, Android Tablets and iPad.

#### **IEC publications search - [www.iec.ch/searchpub](http://www.iec.ch/searchpub)**

The advanced search enables to find IEC publications by a variety of criteria (reference number, text, technical committee,...). It also gives information on projects, replaced and withdrawn publications.

#### **IEC Just Published - [webstore.iec.ch/justpublished](http://webstore.iec.ch/justpublished)**

Stay up to date on all new IEC publications. Just Published details all new publications released. Available online and also once a month by email.

#### **Electropedia - [www.electropedia.org](http://www.electropedia.org)**

The world's leading online dictionary of electronic and electrical terms containing more than 30 000 terms and definitions in English and French, with equivalent terms in 14 additional languages. Also known as the International Electrotechnical Vocabulary (IEV) online.

#### **IEC Glossary - [std.iec.ch/glossary](http://std.iec.ch/glossary)**

More than 55 000 electrotechnical terminology entries in English and French extracted from the Terms and Definitions clause of IEC publications issued since 2002. Some entries have been collected from earlier publications of IEC TC 37, 77, 86 and CISPR.

#### **IEC Customer Service Centre - [webstore.iec.ch/csc](http://webstore.iec.ch/csc)**

If you wish to give us your feedback on this publication or need further assistance, please contact the Customer Service Centre: [csc@iec.ch](mailto:csc@iec.ch).

#### **A propos de l'IEC**

La Commission Electrotechnique Internationale (IEC) est la première organisation mondiale qui élabore et publie des Normes internationales pour tout ce qui a trait à l'électricité, à l'électronique et aux technologies apparentées.

#### **A propos des publications IEC**

Le contenu technique des publications IEC est constamment revu. Veuillez vous assurer que vous possédez l'édition la plus récente, un corrigendum ou amendement peut avoir été publié.

#### **Catalogue IEC - [webstore.iec.ch/catalogue](http://webstore.iec.ch/catalogue)**

Application autonome pour consulter tous les renseignements bibliographiques sur les Normes internationales, Spécifications techniques, Rapports techniques et autres documents de l'IEC. Disponible pour PC, Mac OS, tablettes Android et iPad.

#### **Recherche de publications IEC - [www.iec.ch/searchpub](http://www.iec.ch/searchpub)**

La recherche avancée permet de trouver des publications IEC en utilisant différents critères (numéro de référence, texte, comité d'études,...). Elle donne aussi des informations sur les projets et les publications remplacées ou retirées.

#### **IEC Just Published - [webstore.iec.ch/justpublished](http://webstore.iec.ch/justpublished)**

Restez informé sur les nouvelles publications IEC. Just Published détaille les nouvelles publications parues. Disponible en ligne et aussi une fois par mois par email.

#### **Electropedia - [www.electropedia.org](http://www.electropedia.org)**

Le premier dictionnaire en ligne de termes électroniques et électriques. Il contient plus de 30 000 termes et définitions en anglais et en français, ainsi que les termes équivalents dans 14 langues additionnelles. Egalement appelé Vocabulaire Electrotechnique International (IEV) en ligne.

#### **Glossaire IEC - [std.iec.ch/glossary](http://std.iec.ch/glossary)**

Plus de 55 000 entrées terminologiques électrotechniques, en anglais et en français, extraites des articles Termes et Définitions des publications IEC parues depuis 2002. Plus certaines entrées antérieures extraites des publications des CE 37, 77, 86 et CISPR de l'IEC.

#### **Service Clients - [webstore.iec.ch/csc](http://webstore.iec.ch/csc)**

Si vous désirez nous donner des commentaires sur cette publication ou si vous avez des questions contactez-nous: [csc@iec.ch](mailto:csc@iec.ch).

# INTERNATIONAL STANDARD

AMENDMENT 1

Information technology – Generic cabling systems for data centres

(<https://standards.iteh.ai>)  
Document Preview

ISO/IEC 24764:2010/AMD1:2014

<https://standards.iteh.ai/catalog/standards/iso/ba282137-009f-4b30-baff-1a1f5d79e891/iso-iec-24764-2010-amd1-2014>

INTERNATIONAL  
ELECTROTECHNICAL  
COMMISSION

PRICE CODE

**B**

ICS 35.200

ISBN 978-2-8891-0836-7

**Warning! Make sure that you obtained this publication from an authorized distributor.**

## FOREWORD

Amendment 1 to International Standard ISO/IEC 24764 was prepared by subcommittee 25: Interconnection of information technology equipment, of ISO/IEC joint technical committee 1: Information technology.

This International Standard has been approved by vote of the member bodies, and the voting results may be obtained from the address given on the second title page.

Withdrawing

iTech Standards  
(<https://standards.iteh.ai>)  
Document Preview

ISO/IEC 24764:2010/AMD1:2014

<https://standards.iteh.ai/catalog/standards/iso/ba282137-009f-4b30-baff-1a1f5d79e891/iso-iec-24764-2010-amd1-2014>

Add, to the table of contents, the following new entries:

## CONTENTS

INTRODUCTION to Amendment 1 .....	4
Annex C (normative) Intermediate distribution cabling subsystem .....	7
C.1 General .....	7
C.2 General structure and hierarchy .....	7
C.2.1 General .....	7
C.3 Cabling subsystems .....	8
C.3.1 Main distribution cabling subsystem .....	8
C.3.2 Intermediate distribution cabling subsystem .....	8
C.3.3 Redundancy .....	8
C.4 Transmission performance .....	9
C.4.1 Balanced cabling .....	9
C.4.2 Optical fibre cabling .....	10
C.5 Reference implementations .....	10
C.5.1 Main distribution cabling .....	10
C.5.2 Intermediate distribution cabling .....	12
Annex D (informative) Combination of balanced cabling permanent links .....	15
D.1 General .....	15
D.2 Requirements .....	15
Figure C.1 – Structure of generic cabling within a data centre .....	7
Figure C.2 – Hierarchical structure of generic cabling within a data centre .....	8
Figure C.3 – Connection of functional elements providing redundancy .....	9
Figure C.4 – Main distribution cabling models .....	10
Figure C.5 – Intermediate distribution cabling models .....	12
Figure D.1 – Examples of combined permanent links .....	15
Table C.1 – Length assumptions used in the mathematical modelling of balanced main distribution cabling .....	11
Table C.2 – Main distribution channel length equations .....	11
Table C.3 – Length assumptions used in the mathematical modelling of balanced intermediate distribution cabling .....	13
Table C.4 – Intermediate distribution channel length equations .....	13

Add, at the end of the existing introduction, after Figure 1, the following text:

## INTRODUCTION to Amendment 1

Amendment 1 of ISO/IEC 24764:2010 provides an introduction to the intermediate cabling subsystem and an explanatory annex for the combination of several permanent links to form a single transmission channel.

## 2 Normative references

Add, in the list of normative references, after reference ISO/IEC 11801, the following reference:

ISO/IEC 14763-2, *Information technology – Implementation and operation of customer premises cabling – Part 2: Planning and installation*

### 3.1 Terms and definitions

Add, at the end of this subclause, the following new definitions:

#### 3.1.13

##### **equipment cord**

cord connecting equipment to the equipment interfaces of generic cabling

#### 3.1.14

##### **equipment outlet**

fixed connecting device for terminating the zone distribution cabling and providing the interface to the equipment cord

#### 3.1.15

##### **intermediate distribution cable**

cable connecting the intermediate distributor to the zone distributor

#### 3.1.16

##### **intermediate distributor**

distributor used to make connections between the main distribution cabling subsystem, intermediate distribution cabling subsystem, network access cabling subsystem and cabling subsystems specified in ISO/IEC 11801 and active equipment

## 3.2 Abbreviations

Add, after the entry EO *Equipment Outlet*, the following new abbreviation:

ID Intermediate Distributor

ILD Insertion Loss Deviation

## 5 Structure of the generic cabling system

### 5.2 Functional elements

Add, after item i), the following new NOTE:

NOTE This standard includes additional functional elements, the intermediate distributor and the intermediate distribution cable. The requirements for these functional elements are defined in Annex C.

### 5.3 General structure and hierarchy

Replace the entire third paragraph by the following new paragraph and NOTE:

The functions of multiple distributors may be combined, see 5.7.1.

NOTE This standard includes an additional cabling subsystem: the intermediate cabling subsystem. The requirements for this additional cabling subsystem and the modifications to the cabling subsystems of this clause are defined in Annex C.

Replace the existing Figure 2 by the following Figure:

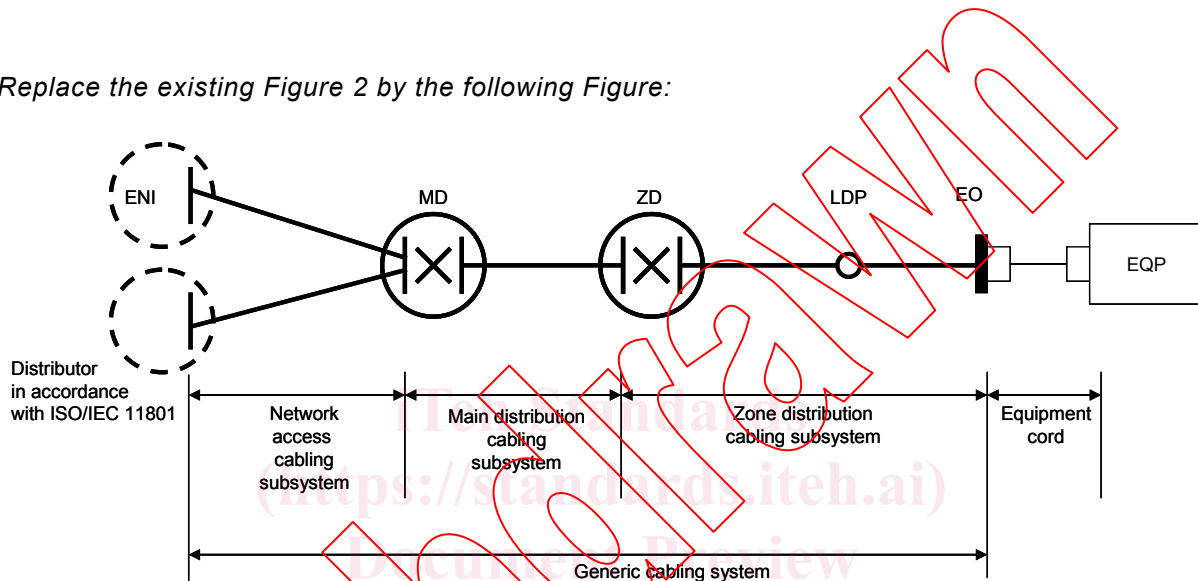

### 5.6 Interfaces

#### 5.6.2 Channels and links

Replace the existing second and third paragraphs by the following:

The channel is the transmission path between data centre equipment such as switches and servers (EQP in Figure 5). A typical channel in a data centre would consist of the zone distribution cabling subsystem together with an equipment cord at each end. For longer reach services, the channel would be formed by the connection of two or more subsystems (including patch cords and equipment cords), see Annex D. The performance of the channel excludes the connections at the application-specific equipment.

The permanent link is the transmission path of the fixed cabling subsystem, including the connecting hardware at the ends of the installed cable. In a data centre zone distribution cabling subsystem, the permanent link consists of the EO, an optional LDP cable, an optional LDP, the zone distribution cable and the termination of the zone distribution cable at the zone distributor. The permanent link includes the connections at the ends of the installed cabling.

## 6 Channel performance

### 6.1 General

Replace the third paragraph including bulleted list by:

Channels are implemented using either:

- network access cabling only;
- main distribution cabling only;
- zone distribution cabling only;
- a combination of the above, see Annex D.

*Add, after Annex B, the following new Annexes C and D, and move the existing Bibliography after these new Annexes:*

Withdrawing

iTech Standards  
(<https://standards.iteh.ai>)  
Document Preview

ISO/IEC 24764:2010/AMD1:2014  
<https://standards.iteh.ai/catalog/standards/iso/ba282187-009f-4b30-baff-1a1f5d79e891/iso-iec-24764-2010-amd1-2014>



## Annex C (normative)

### Intermediate distribution cabling subsystem

#### C.1 General

Depending on the size and/or complexity of the data centres, it may require an additional subsystem in order to allow for the connection of several zone distributors. In such cases, the main distributor connects several intermediate distributors, each of which acts as local main distributors.

This annex will describe the additional requirements that are required for such implementations.

#### C.2 General structure and hierarchy

##### C.2.1 General

The cabling subsystems are connected together to create a generic cabling system with a structure as shown in Figure C.1. The composition of the cabling subsystems is described in 5.4.2, 5.4.3 and 5.4.4. The functional elements of the cabling subsystems are connected to form a basic hierarchical topology as shown in Figure C.2.

Network access cabling subsystems may be connected directly to the intermediate distributor. Cabling subsystems, as specified in ISO/IEC 11801, may also be connected directly to the intermediate distributor.

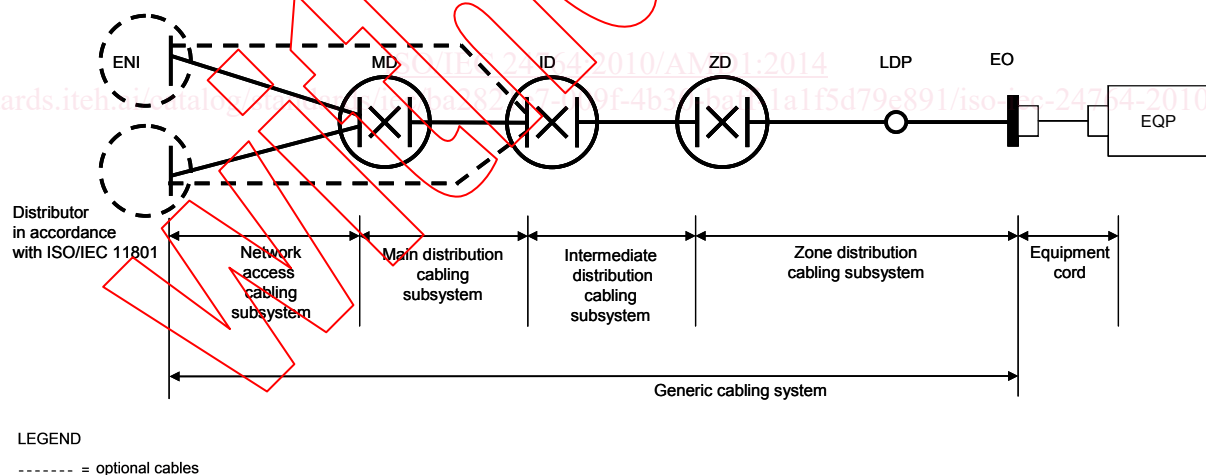
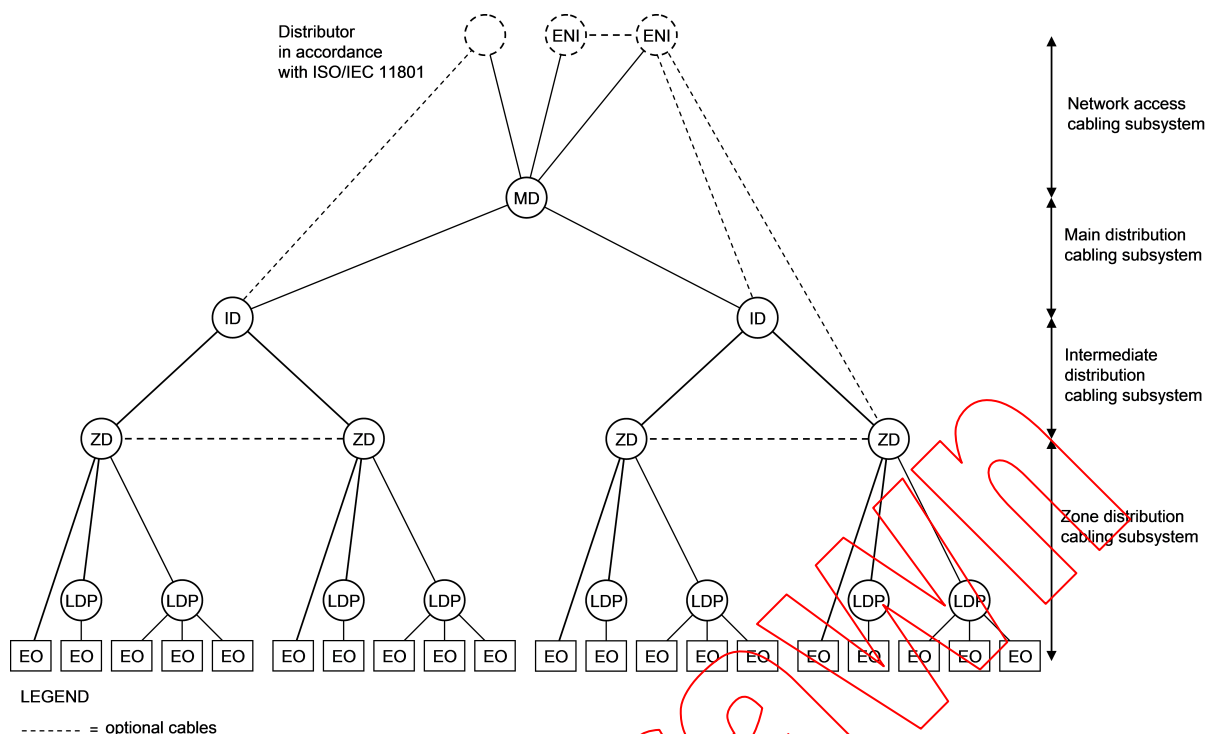

Figure C.1 – Structure of generic cabling within a data centre



**Figure C.2 – Hierarchical structure of generic cabling within a data centre**

### C.3 Cabling subsystems

#### C.3.1 Main distribution cabling subsystem

The main distribution cabling subsystem extends from an MD to the ID(s) connected to it. The subsystem includes:

- the main distribution cables;
- the mechanical termination of the main distribution cables at the MD together with associated patch cords and/or jumpers at the MD;
- the mechanical termination of the main distribution cables at the ID(s).

#### C.3.2 Intermediate distribution cabling subsystem

The intermediate distribution cabling subsystem extends from an ID to the ZD(s) connected to it.

The subsystem includes:

- the intermediate distribution cables;
- the mechanical termination of the intermediate distribution cables at the ID together with associated patch cords and/or jumpers at the ID;
- the mechanical termination of the intermediate distribution cables at the ZD(s).

#### C.3.3 Redundancy

Consideration should be given to the resilience of the data centre with respect to the cabling infrastructure. This may be enhanced by the provision of redundant distributors, cabling, and pathways.