



Designation: D 4912 – 02

Standard Test Method for Fabric Stability of Vinyl-Coated Glass Yarn Insect Screening and Louver Cloth¹

This standard is issued under the fixed designation D 4912; the number immediately following the designation indicates the year of original adoption or, in the case of revision, the year of last revision. A number in parentheses indicates the year of last reapproval. A superscript epsilon (ϵ) indicates an editorial change since the last revision or reapproval.

1. Scope

1.1 This test method provides a procedure for evaluating fabric stability by measuring the resistance to yarn slippage of filling yarns over warp yarns, or warp yarns over filling yarns in vinyl-coated glass yarn insect screening and louver cloth.

1.2 This test method shows the values in both SI units and inch-pound units. “SI units” is the technically correct name for a system of metric units known as the International System of Units. “Inch-pound units” is the technically correct name for the customary units used in the United States. The values expressed in each system may not be exact equivalents; therefore, each system shall be used independently of the other. Combining values from the two systems may result in non-conformance with this standard.

1.3 *This standard does not purport to address all of the safety concerns, if any, associated with its use. It is the responsibility of the user of this standard to establish appropriate safety and health practices and determine the applicability of regulatory limitations prior to use.*

2. Referenced Documents

2.1 ASTM Standards:

- D 76 Specification for Tensile Testing Machines for Textiles²
- D 123 Terminology Relating to Textiles²
- D 4028 Specification for Solar Screening Woven from Vinyl-Coated Fiber Glass Yarn³
- E 171 Specification for Standard Atmospheres for Conditioning and Testing Materials⁴

3. Terminology

3.1 Definitions:

¹ This test method is under the jurisdiction of ASTM Committee D13 on Textiles and is the direct responsibility of Subcommittee D13.18 on Glass Fiber and Its Products.

Current edition approved May 10, 2002. Published August 2002. Originally published as D 4912–89. Last previous edition D 4912–89(1994)

² *Annual Book of ASTM Standards*, Vol 07.01.

³ *Annual Book of ASTM Standards*, Vol 07.02.

⁴ *Annual Book of ASTM Standards*, Vol 08.03.

3.1.1 *atmosphere for testing textiles, n*—for glass, air maintained at a relative humidity of at least 48 % and no greater than 67 %, and at a temperature of at least 20°C (68°F) and no greater than 25°C (77°F).

3.1.1.1 *Discussion*—Glass textiles are used in various products such as reinforced plastics, mat-like material, tire cords, electrical insulation, etc. Each of these materials requires different testing atmospheres. It is the intent of the wide spread in testing atmosphere to allow testing of glass textiles in respective laboratories where end-product test atmosphere requirements differ. The test atmospheres for respective products should be controlled as specified in Specification E 171. It is the opinion of ASTM Subcommittee D13.18 that fabric stability of insect screening and louver cloth would not be affected by the range selected. In any event, the test atmosphere should be stated in the report.

3.1.2 *fabric stability, n*—in vinyl coated glass screening and louver cloth, the property denoting the ability to resist slippage of yarn segments in one direction over yarn segments in the opposite direction.

3.1.3 For definitions of other textile terms used in this test method, refer to Terminology D 123.

4. Summary of Test Method

4.1 Samples of the vinyl-coated glass yarn insect screening or louver cloth are subjected to a breaking force test where yarns have been severed within the gage length area. The force required to break the fused bond between yarn components and slip yarn segments in one direction over yarn segments in the opposite direction is reported as the *fabric stability*.

5. Significance and Use

5.1 This test method is considered satisfactory for acceptance testing of commercial shipments since the method has been used extensively in the trade for acceptance testing.

5.1.1 In cases of a dispute arising from differences in reported test results when using this test method for acceptance testing of commercial shipments, the purchaser and the supplier should conduct comparative tests to determine if there is a statistical bias between their laboratories. Competent statistical assistance is recommended for the investigation of bias.

As a minimum, the two parties should take a group of test specimens which are as homogeneous as possible and which are from a lot of material of the type in question. The test specimens should then be randomly assigned in equal numbers to each laboratory for testing. The average results from the two laboratories should be compared using Student's *t*-test for unpaired data and an acceptable probability level chosen by the two parties before the testing begins. If a bias is found, either its cause must be found and corrected or the purchaser and the supplier must agree to interpret future test results in the light of the known bias.

5.2 Vinyl-coated glass yarn insect screening and louver cloth are subjected to a heating process to fuse the warp yarns to the filling yarns of the woven structure. The force at which yarns in one direction move over yarns in the opposite direction is a measure of the bond of fusion. The degree of the bond of fusion on the vinyl-coated glass yarn insect screening and louver cloth is used for process control. Fabric stability was formerly called resistance to yarn slippage.

6. Apparatus

6.1 *Tensile Testing Machine*—In case of dispute a constant-rate-of-extension, CRE, tensile testing machine as described in Specification D 76 will be used. When agreed upon between the purchaser and the supplier, a constant-rate-of-traverse tensile, CRT, testing machine can be used.

6.1.1 The clamp faces shall be rubber or smooth metallic faced at least 10 mm (0.4 in.) wider than the specimen width and with a minimum of 25 mm (1 in.) in the direction of application of force.

NOTE 1—The covering of the metallic faces with approximately a 3-mm (0.11-in.) thick cardboard or other suitable material has been found useful for preventing crushing of the specimen.

7. Sampling and Number of Specimens

7.1 *Lot Size*—A lot is defined as a single shipment of a single type of glass textile. A lot may constitute all or part of a single customer order.

7.2 *Lot Sample*—As a lot sample for acceptance testing, take the number of rolls of insect screening or louver cloth directed in an applicable material specification or other agreement between the purchaser and the supplier. Consider rolls of insect screening or louver cloth to be the primary sampling unit. In the absence of such an agreement, take the number of rolls specified in Table 1.

TABLE 1 Number of Rolls of Fabric in the Lot Sample

Total Length of Fabric in Lot		Number of Lot Sampling Units
m	ft	
245 or less	800 or less	2
246 to 6700, inclusive	801 to 22 000, inclusive	3
6701 and over	22 001 and over	5

NOTE 2—An adequate specification or other agreement between the purchaser and the supplier requires taking into account the variability between rolls of insect screening or louver cloth and between test specimens from a swatch or roll of insect screening or louver cloth to produce a sampling plan with meaningful producer's risk, consumer's risk, acceptable quality level, and limiting quality level.

7.3 *Laboratory Sample*—As a laboratory sample for acceptance testing, proceed as directed in an applicable material specification or other agreement between the purchaser and the supplier. In the absence of such an agreement, use the lot sampling units for the laboratory sampling units. Take a full width swatch, 2 m (2 yd) long, from each selected lot sampling unit of screening or louver cloth. Take swatches after first discarding a minimum of 1 m (1 yd) from the very outside of the roll.

7.4 *Test Specimens*—From each swatch in the laboratory sample, cut five specimens in each the warp and filling direction, 50 by 125 mm (2 by 5 in.) with the long dimension respectively parallel to the warp and filling yarns. Cut alternate lengthwise yarns as shown in Fig. 1. Cut yarns equidistant from the center of the specimen length having three widthwise yarns between the yarns cut above the center of the specimen length (Cut A) and the yarns cut below the center of the specimen length (cut B). Ensure each lengthwise yarn has only one cut. The short direction is the direction of test. Take test specimens from each swatch in the laboratory sample in such a way that no specimen is closer than one tenth the width of the swatch from the selvage with no two specimens cut parallel to the warp containing the same set of warp ends or if cut parallel to the filling, containing the same set of filling picks, and the specimens from different swatches are each taken from a different part of the width of the swatches.

8. Procedure

8.1 Condition the laboratory samples without preconditioning for period of at least 5 h in the atmosphere for testing glass textiles, unless otherwise specified.

NOTE 3—In any event, 24 h is considered ample exposure to bring the

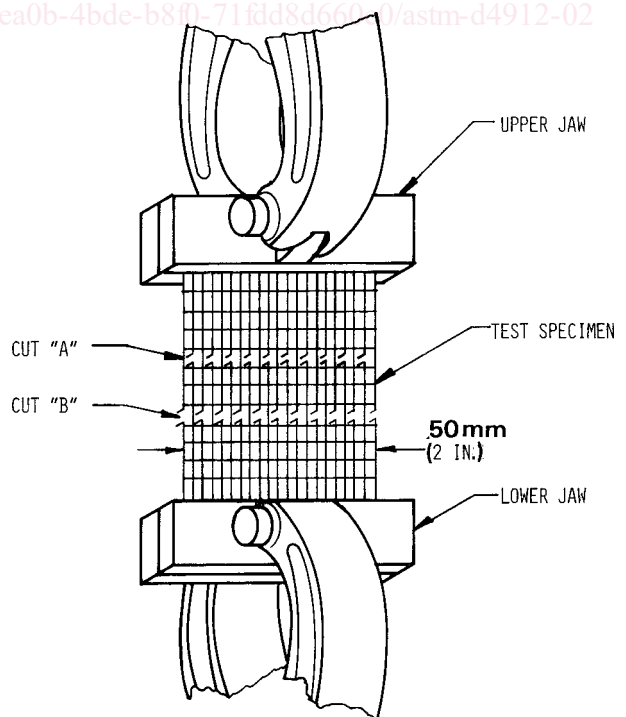

FIG. 1 Screening, Nonmetallic, Insert; Cut Pattern of Specimen