

INTERNATIONAL STANDARD

NORME INTERNATIONALE



**Arc welding equipment –
Part 10: Electromagnetic compatibility (EMC) requirements**

**Matériel de soudage à l'arc –
Partie 10: Exigences de compatibilité électromagnétique (CEM)**

<https://standards.iteh.ai/catalog/standards/sist/49870f6e-7eaa-4198-8b20-9084571e999b/iec-60974-10-2014>



THIS PUBLICATION IS COPYRIGHT PROTECTED

Copyright © 2015 IEC, Geneva, Switzerland

All rights reserved. Unless otherwise specified, no part of this publication may be reproduced or utilized in any form or by any means, electronic or mechanical, including photocopying and microfilm, without permission in writing from either IEC or IEC's member National Committee in the country of the requester. If you have any questions about IEC copyright or have an enquiry about obtaining additional rights to this publication, please contact the address below or your local IEC member National Committee for further information.

Droits de reproduction réservés. Sauf indication contraire, aucune partie de cette publication ne peut être reproduite ni utilisée sous quelque forme que ce soit et par aucun procédé, électronique ou mécanique, y compris la photocopie et les microfilms, sans l'accord écrit de l'IEC ou du Comité national de l'IEC du pays du demandeur. Si vous avez des questions sur le copyright de l'IEC ou si vous désirez obtenir des droits supplémentaires sur cette publication, utilisez les coordonnées ci-après ou contactez le Comité national de l'IEC de votre pays de résidence.

IEC Central Office
3, rue de Varembe
CH-1211 Geneva 20
Switzerland

Tel.: +41 22 919 02 11
Fax: +41 22 919 03 00
info@iec.ch
www.iec.ch

About the IEC

The International Electrotechnical Commission (IEC) is the leading global organization that prepares and publishes International Standards for all electrical, electronic and related technologies.

About IEC publications

The technical content of IEC publications is kept under constant review by the IEC. Please make sure that you have the latest edition, a corrigenda or an amendment might have been published.

IEC Catalogue - webstore.iec.ch/catalogue

The stand-alone application for consulting the entire bibliographical information on IEC International Standards, Technical Specifications, Technical Reports and other documents. Available for PC, Mac OS, Android Tablets and iPad.

IEC publications search - www.iec.ch/searchpub

The advanced search enables to find IEC publications by a variety of criteria (reference number, text, technical committee,...). It also gives information on projects, replaced and withdrawn publications.

IEC Just Published - webstore.iec.ch/justpublished

Stay up to date on all new IEC publications. Just Published details all new publications released. Available online and also once a month by email.

Electropedia - www.electropedia.org

The world's leading online dictionary of electronic and electrical terms containing more than 30 000 terms and definitions in English and French, with equivalent terms in 15 additional languages. Also known as the International Electrotechnical Vocabulary (IEV) online.

IEC Glossary - std.iec.ch/glossary

More than 60 000 electrotechnical terminology entries in English and French extracted from the Terms and Definitions clause of IEC publications issued since 2002. Some entries have been collected from earlier publications of IEC TC 37, 77, 86 and CISPR.

IEC Customer Service Centre - webstore.iec.ch/csc

If you wish to give us your feedback on this publication or need further assistance, please contact the Customer Service Centre: csc@iec.ch.

A propos de l'IEC

La Commission Electrotechnique Internationale (IEC) est la première organisation mondiale qui élabore et publie des Normes internationales pour tout ce qui a trait à l'électricité, à l'électronique et aux technologies apparentées.

A propos des publications IEC

Le contenu technique des publications IEC est constamment revu. Veuillez vous assurer que vous possédez l'édition la plus récente, un corrigendum ou amendement peut avoir été publié.

Catalogue IEC - webstore.iec.ch/catalogue

Application autonome pour consulter tous les renseignements bibliographiques sur les Normes internationales, Spécifications techniques, Rapports techniques et autres documents de l'IEC. Disponible pour PC, Mac OS, tablettes Android et iPad.

Recherche de publications IEC - www.iec.ch/searchpub

La recherche avancée permet de trouver des publications IEC en utilisant différents critères (numéro de référence, texte, comité d'études,...). Elle donne aussi des informations sur les projets et les publications remplacées ou retirées.

IEC Just Published - webstore.iec.ch/justpublished

Restez informé sur les nouvelles publications IEC. Just Published détaille les nouvelles publications parues. Disponible en ligne et aussi une fois par mois par email.

Electropedia - www.electropedia.org

Le premier dictionnaire en ligne de termes électroniques et électriques. Il contient plus de 30 000 termes et définitions en anglais et en français, ainsi que les termes équivalents dans 15 langues additionnelles. Egalement appelé Vocabulaire Electrotechnique International (IEV) en ligne.

Glossaire IEC - std.iec.ch/glossary

Plus de 60 000 entrées terminologiques électrotechniques, en anglais et en français, extraites des articles Termes et Définitions des publications IEC parues depuis 2002. Plus certaines entrées antérieures extraites des publications des CE 37, 77, 86 et CISPR de l'IEC.

Service Clients - webstore.iec.ch/csc

Si vous désirez nous donner des commentaires sur cette publication ou si vous avez des questions contactez-nous: csc@iec.ch.

INTERNATIONAL STANDARD

NORME INTERNATIONALE



**Arc welding equipment –
Part 10: Electromagnetic compatibility (EMC) requirements**

**Matériel de soudage à l'arc –
Partie 10: Exigences de compatibilité électromagnétique (CEM)**

<https://standards.iteh.ai/catalog/standards/sist/49870f6e-7eaa-4198-8b20-9084571e999b/iec-60974-10-2014>

INTERNATIONAL
ELECTROTECHNICAL
COMMISSION

COMMISSION
ELECTROTECHNIQUE
INTERNATIONALE

ICS 25.160

ISBN 978-2-8322-2764-0

**Warning! Make sure that you obtained this publication from an authorized distributor.
Attention! Veuillez vous assurer que vous avez obtenu cette publication via un distributeur agréé.**

REDLINE VERSION

VERSION REDLINE



**Arc welding equipment –
Part 10: Electromagnetic compatibility (EMC) requirements**

**Matériel de soudage à l'arc –
Partie 10: Exigences de compatibilité électromagnétique (CEM)**

<https://standards.iteh.ai/catalog/standards/sist/49870f6e-7eaa-4198-8b20-9084571e999b/iec-60974-10-2014>

CONTENTS

FOREWORD.....	5
1 Scope.....	7
2 Normative references	7
3 Terms and definitions	8
4 General test requirements	9
4.1 Test conditions	9
4.2 Measuring instruments.....	9
4.3 Artificial mains network	9
4.4 Voltage probe	10
4.5 Antennas	10
4.6 Load-decoupling network	10
5 Test setup for emission and immunity.....	10
5.1 General.....	10
5.2 Load	13
5.3 Ancillary equipment	13
5.3.1 General requirements	13
5.3.2 Wire feeders	13
5.3.3 Remote controls	14
5.3.4 Arc striking and stabilizing devices	14
5.3.5 Liquid cooling systems.....	14
6 Emission tests	14
6.1 Classification for RF emission tests	14
6.1.1 Class A equipment.....	14
6.1.2 Class B equipment.....	14
6.2 Test conditions	15
6.2.1 Welding power source	15
6.2.2 Load voltages	16
6.2.3 Wire feeders	16
6.2.4 Ancillary equipment	16
6.3 Emission limits.....	16
6.3.1 General	16
6.3.2 Mains terminal disturbance voltage.....	16
6.3.3 Electromagnetic radiation disturbance	17
6.3.4 Harmonics, voltage fluctuations and flicker	17
6.3.5 Output current ripple.....	19
7 Immunity tests	19
7.1 Classification for immunity tests.....	19
7.1.1 Applicability of tests.....	19
7.1.2 Category 1 equipment.....	19
7.1.3 Category 2 equipment.....	19
7.2 Test conditions	19
7.3 Immunity performance criteria.....	20
7.3.1 Performance criterion A	20
7.3.2 Performance criterion B	20
7.3.3 Performance criterion C.....	20

7.4	Immunity levels	20
8	Documentation for the purchaser/user	22
Annex A (informative)	Installation and use	24
A.1	General	24
A.2	Assessment of area	24
A.3	Assessment of welding installation	24
A.4	Mitigation measures	25
A.4.1	Public supply system	25
A.4.2	Maintenance of the arc welding equipment	25
A.4.3	Welding cables	25
A.4.4	Equipotential bonding	25
A.4.5	Earthing of the workpiece	25
A.4.6	Screening and shielding	25
Annex B (informative)	Limits	26
B.1	General	26
B.2	Mains terminal disturbance voltage limits	26
B.3	Electromagnetic radiation disturbance limits	27
B.4	Harmonic current limits	28
B.5	Limits for voltage fluctuations and flicker	30
Annex C (informative)	Symbols	31
Bibliography	32
Figure 1	– Test set-up 1 for arc welding equipment	11
Figure 2	– Test set-up 2 for portable arc welding equipment	12
Figure 3	– Top view of test setup as shown in Figure 1	12
Figure 4	– Overview of harmonic requirements for supply current up to 75 A	18
Figure 5	– Overview of flicker requirements	18
Table 1	– Immunity levels – Enclosure	21
Table 2	– Immunity levels – AC input power port	21
Table 3	– Immunity levels – Ports for measurement and control	22
Table 4	– Output current ripple limits for Class B arc welding power sources	19
Table B.1	– Mains terminal disturbance voltage limits, idle state	26
Table B.2	– Mains terminal disturbance voltage limits, load conditions	26
Table B.3	– Electromagnetic radiation disturbance limits, idle state	27
Table B.4	– Electromagnetic radiation disturbance limits, load conditions	27
Table B.5	– Maximum permissible harmonic current for equipment for non-professional use with input current $I_{1max} \leq 16$ A	28
Table B.6	– Current emission limits for equipment with $I_{1max} \leq 75$ A other than balanced three-phase equipment	28
Table B.7	– Current emission limits for balanced three-phase equipment with $I_{1max} \leq 75$ A	29
Table B.8	– Current emission limits for balanced three-phase equipment with $I_{1max} \leq 75$ A under specified conditions (a, b, c)	29
Table B.9	– Current emission limits for balanced three-phase equipment with $I_{1max} \leq 75$ A under specified conditions (d, e, f)	29

Table B.10 – Limits for arc welding equipment with $I_{1\max} \leq 75$ A 30
Table C.1 – Symbols to describe EMC properties 31

Withhold

iTeh STANDARD PREVIEW
(standards.iteh.ai)

<https://standards.iteh.ai/catalog/standards/sist/42820f6e-7caa-4198-8b20-9084571e999b/iec-60974-10-2014>

INTERNATIONAL ELECTROTECHNICAL COMMISSION

ARC WELDING EQUIPMENT –

Part 10: Electromagnetic compatibility (EMC) requirements

FOREWORD

- 1) The International Electrotechnical Commission (IEC) is a worldwide organization for standardization comprising all national electrotechnical committees (IEC National Committees). The object of IEC is to promote international co-operation on all questions concerning standardization in the electrical and electronic fields. To this end and in addition to other activities, IEC publishes International Standards, Technical Specifications, Technical Reports, Publicly Available Specifications (PAS) and Guides (hereafter referred to as "IEC Publication(s)"). Their preparation is entrusted to technical committees; any IEC National Committee interested in the subject dealt with may participate in this preparatory work. International, governmental and non-governmental organizations liaising with the IEC also participate in this preparation. IEC collaborates closely with the International Organization for Standardization (ISO) in accordance with conditions determined by agreement between the two organizations.
- 2) The formal decisions or agreements of IEC on technical matters express, as nearly as possible, an international consensus of opinion on the relevant subjects since each technical committee has representation from all interested IEC National Committees.
- 3) IEC Publications have the form of recommendations for international use and are accepted by IEC National Committees in that sense. While all reasonable efforts are made to ensure that the technical content of IEC Publications is accurate, IEC cannot be held responsible for the way in which they are used or for any misinterpretation by any end user.
- 4) In order to promote international uniformity, IEC National Committees undertake to apply IEC Publications transparently to the maximum extent possible in their national and regional publications. Any divergence between any IEC Publication and the corresponding national or regional publication shall be clearly indicated in the latter.
- 5) IEC itself does not provide any attestation of conformity. Independent certification bodies provide conformity assessment services and, in some areas, access to IEC marks of conformity. IEC is not responsible for any services carried out by independent certification bodies.
- 6) All users should ensure that they have the latest edition of this publication.
- 7) No liability shall attach to IEC or its directors, employees, servants or agents including individual experts and members of its technical committees and IEC National Committees for any personal injury, property damage or other damage of any nature whatsoever, whether direct or indirect, or for costs (including legal fees) and expenses arising out of the publication, use of, or reliance upon, this IEC Publication or any other IEC Publications.
- 8) Attention is drawn to the Normative references cited in this publication. Use of the referenced publications is indispensable for the correct application of this publication.
- 9) Attention is drawn to the possibility that some of the elements of this IEC Publication may be the subject of patent rights. IEC shall not be held responsible for identifying any or all such patent rights.

This consolidated version of the official IEC Standard and its amendment has been prepared for user convenience.

IEC 60974-10 edition 3.1 contains the third edition (2014-02) [documents 26/519/FDIS and 26/526/RVD] and its amendment 1 (2015-06) [documents 26/549/CDV and 26/560/RVC].

In this Redline version, a vertical line in the margin shows where the technical content is modified by amendment 1. Additions and deletions are displayed in red, with deletions being struck through. A separate Final version with all changes accepted is available in this publication.

International Standard IEC 60974-10 has been prepared by IEC technical committee 26: Electric welding.

This edition includes the following significant technical changes with respect to the previous edition:

- inclusion of optional use of a decoupling network and a load outside the test chamber;
- inclusion of an alternative test setup for portable equipment;
- inclusion of test conditions for complex controls, liquid cooling systems and arc striking and stabilizing devices;
- update of the applicable limits related to the updated reference to CISPR 11;
- exclusion of the use of narrow band relaxations for RF emission limits;
- update of the applicable limits for harmonics and flicker and inclusion of flow-charts related to the updated reference to IEC 61000-3-11 and IEC 61000-3-12;
- update of the requirements for voltage dips related to the updated reference to IEC 61000-4-11 and IEC 61000-4-34;
- update of the informative annex for installation and use,
- inclusion of symbols to indicate the RF equipment class and restrictions for use.

This publication has been drafted in accordance with the ISO/IEC Directives, Part 2.

The list of all the parts of the IEC 60974 series, under the general title *Arc welding equipment*, can be found on the IEC web site.

The committee has decided that the contents of the base publication and its amendment will remain unchanged until the stability date indicated on the IEC web site under "<http://webstore.iec.ch>" in the data related to the specific publication. At this date, the publication will be

- reconfirmed,
- withdrawn,
- replaced by a revised edition, or
- amended.

IMPORTANT – The 'colour inside' logo on the cover page of this publication indicates that it contains colours which are considered to be useful for the correct understanding of its contents. Users should therefore print this document using a colour printer.

ARC WELDING EQUIPMENT –

Part 10: Electromagnetic compatibility (EMC) requirements

1 Scope

This part of IEC 60974 specifies

- a) applicable standards and test methods for radio-frequency (RF) emissions,
- b) applicable standards and test methods for harmonic current emission, voltage fluctuations and flicker;
- c) immunity requirements and test methods for continuous and transient, conducted and radiated disturbances including electrostatic discharges.

This standard is applicable to equipment for arc welding and allied processes, including power sources and ancillary equipment, for example wire feeders, liquid cooling systems and arc striking and stabilizing devices.

NOTE 1 Allied processes are, for example, plasma cutting and arc stud welding.

NOTE 2 This standard does not specify basic safety requirements for arc welding equipment such as protection against electric shock, unsafe operation, insulation coordination and related dielectric tests.

Arc welding equipment type tested in accordance with, and which has met the requirements of, this standard is considered to be in compliance for all applications.

2 Normative references

The following documents, in whole or in part, are normatively referenced in this document and are indispensable for its application. For dated references, only the edition cited applies. For undated references, the latest edition of the referenced document (including any amendments) applies.

IEC 60050 (all parts), *International Electrotechnical Vocabulary* (available at <<http://www.electropedia.org>>)

IEC 60974-1, *Arc welding equipment – Part 1: Welding power sources*

IEC 60974-6, *Arc welding equipment – Part 6: Limited duty equipment*

IEC 61000-3-2:2005, *Electromagnetic compatibility (EMC) – Part 3-2: Limits – Limits for harmonic current emissions (equipment input current ≤ 16 A per phase)*
Amendment 1:2008
Amendment 2:2009

IEC 61000-3-3:2013, *Electromagnetic compatibility (EMC) – Part 3-3: Limits – Limitation of voltage changes, voltage fluctuations and flicker in public low-voltage supply systems, for equipment with rated current ≤ 16 A per phase and not subject to conditional connection*

IEC 61000-3-11:2000, *Electromagnetic compatibility (EMC) – Part 3-11: Limits – Limitation of voltage changes, voltage fluctuations and flicker in public low-voltage supply systems – Equipment with rated current ≤ 75 A and subject to conditional connection*

IEC 61000-3-12:2011, *Electromagnetic compatibility (EMC) – Part 3-12: Limits for harmonic currents produced by equipment connected to public low-voltage systems with input current > 16 A and ≥ 75 A per phase*

IEC 61000-4-2, *Electromagnetic compatibility (EMC) – Part 4-2: Testing and measurement techniques – Electrostatic discharge immunity test*

IEC 61000-4-3, *Electromagnetic compatibility (EMC) – Part 4-3: Testing and measurement techniques – Radiated, radio-frequency, electromagnetic field immunity test*

IEC 61000-4-4, *Electromagnetic compatibility (EMC) – Part 4-4: Testing and measurement techniques – Electrical fast transient/burst immunity test*

IEC 61000-4-5, *Electromagnetic compatibility (EMC) – Part 4-5: Testing and measurement techniques – Surge immunity test*

IEC 61000-4-6, *Electromagnetic compatibility (EMC) – Part 4-6: Testing and measurement techniques – Immunity to conducted disturbances, induced by radio-frequency fields*

IEC 61000-4-11, *Electromagnetic compatibility (EMC) – Part 4-11: Testing and measurement techniques – Voltage dips, short interruptions and voltage variations immunity tests*

IEC 61000-4-34, *Electromagnetic compatibility (EMC) – Part 4-34: Testing and measurement techniques – Voltage dips, short interruptions and voltage variations immunity tests for equipment with input current more than 16 A per phase*

CISPR 11:2009, *Industrial, scientific and medical equipment – Radio-frequency disturbance characteristics – Limits and methods of measurement¹*
Amendment 1:2010

CISPR 16-1-1, *Specification for radio disturbance and immunity measuring apparatus and methods – Part 1-1: Radio disturbance and immunity measuring apparatus – Measuring apparatus*

CISPR 16-1-2, *Specification for radio disturbance and immunity measuring apparatus and methods – Part 1-2: Radio disturbance and immunity measuring apparatus – Ancillary equipment – Conducted disturbances*

CISPR 16-1-4, *Specification for radio disturbance and immunity measuring apparatus and methods – Part 1-4: Radio disturbance and immunity measuring apparatus – Antennas and test sites for radiated disturbance measurements*

3 Terms and definitions

For the purposes of this document, the terms and definitions given in IEC 60050-161 concerning EMC and the relevant phenomena, given in IEC 60050-851 on arc welding equipment and in IEC 60974-1, as well as the following, apply.

3.1 click

disturbance which exceeds the limit of continuous disturbance no longer than 200 ms and which is separated from a subsequent disturbance by at least 200 ms

Note 1 to entry: Both intervals are related to the level of the limit of continuous disturbance.

¹ There exists a consolidated edition 5.1 (2010) that includes Edition 5 and its Amendment 1.

Note 2 to entry: A click may contain a number of impulses, in which case the relevant time is that from the beginning of the first to the end of the last impulse.

3.2

CDN

coupling/decoupling network

3.3

EUT

equipment under test

3.4

idle state

operating state in which the power is switched on and the welding circuit is not energized

Note 1 to entry: For some types of equipment there is no idle state, but an operating state preceding arc striking, when the welding circuit is energized.

Note 2 to entry: Idle state is different from standby mode, when the power is switched off.

3.5

portable, adj

capable to be carried by one person

Note 1 to entry: Portability is typically specified by the equipment manufacturer based on the intended use, the equipment design and/or local regulation.

[SOURCE: IEC 60050-151:2001, 151-16-47, modified – update of the note]

3.6

small equipment

equipment, either positioned on a table top or standing on the floor which, including its cables fits in a cylindrical test volume of 1,2 m in diameter and 1,5 m above the ground plane

[SOURCE: CISPR 11:2009, Amendment 1:2010, 3.10]

4 General test requirements

4.1 Test conditions

Tests shall be carried out on completely assembled equipment representative of the series production. Tests shall be performed within the specified operating conditions given in IEC 60974-1 or IEC 60974-6, and at the rated supply voltage and frequency. Results obtained for RF emission and immunity at 50 Hz are valid for the same model operating at 60 Hz and vice versa.

4.2 Measuring instruments

The measuring equipment shall comply with the requirements of CISPR 16-1-1 and the standards referred to in Tables 1, 2 and 3 as applicable.

4.3 Artificial mains network

Measurement of the mains terminal disturbance voltage shall be made using an artificial mains network, if commercially available, consisting of 50 Ω /50 μ H V-network as specified in CISPR 16-1-2.

The artificial network is required to provide a defined impedance at RF across the mains supply at the point of measurement and also to provide for isolation of the equipment under test from ambient noise on the power lines.

4.4 Voltage probe

A voltage probe as specified in CISPR 16-1-2 shall be used when the artificial mains network cannot be used. The probe is connected sequentially between each line and the reference earth. The probe shall consist of a blocking capacitor and a resistor such that the total resistance between the line and earth is at least 1 500 Ω . The effect on the accuracy of measurement of the capacitor or any other device which may be used to protect the measuring receiver against dangerous currents shall be either less than 1 dB or allowed for in calibration.

4.5 Antennas

In the frequency range from 30 MHz to 1 GHz, the antenna(s) used shall be as specified in CISPR 16-1-4. Measurements shall be made for both horizontal and vertical polarization. The nearest point of the antenna(s) to the ground shall be not less than 0,2 m.

4.6 Load-decoupling network

If a shielded chamber is required and the load is situated outside the shielded chamber, a load-decoupling network connected to the outside load via suitable RF filters shall be used inside the chamber. A 150 Ω CDN AF 2, as specified in IEC 61000-4-6, suitable for the respective load current and voltage, shall be used. The RF port of the CDN shall be terminated with 50 Ω .

5 Test setup for emission and immunity

5.1 General

Emission and immunity testing of equipment that is not portable shall be carried out on equipment configured in accordance with Figure 1. For portable equipment, either the test setup given in Figure 1 or the test setup given in Figure 2 shall be used. Arc welding equipment tested in one of these configurations shall be considered to have met the necessary requirements of this standard.

For the measurement of the output current ripple, there are no specific requirements for the equipment configuration.

In any situation where it is necessary to re-test the equipment to show compliance with this standard the test setup originally chosen shall be used in order to guarantee consistency of the results, unless it is agreed by the manufacturer to do otherwise.

For RF emission, EM field immunity, common mode immunity, and fast transient immunity tests the following dimensions apply:

In Figure 1, a shall be 1 m

In Figures 1 and 2, b shall be 0,4 m or less

In Figure 2, h shall be 0,8 m

Dimensions a , b and h are undefined for all other tests.

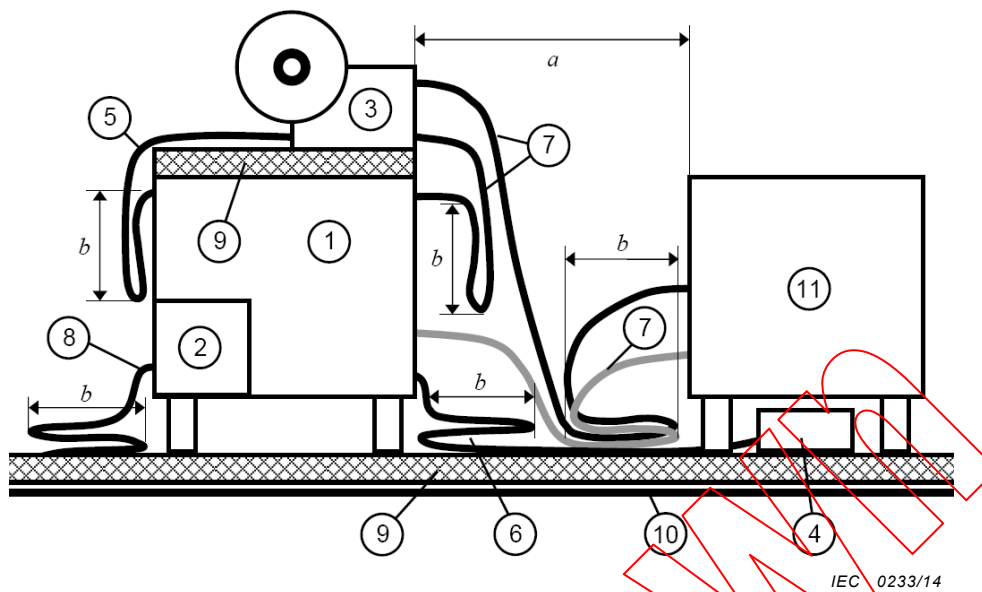

IEC 0233/14

Key

- | | | | |
|---|---------------------------------|----|--|
| 1 | Welding power source | 7 | Welding cable (bundled) |
| 2 | Liquid cooling system | 8 | Input supply cable (bundled) |
| 3 | Wire feeder | 9 | Insulation |
| 4 | Remote control | 10 | Reference ground plane |
| 5 | Interconnection cable (bundled) | 11 | Conventional load or load decoupling network |
| 6 | Remote control cable (bundled) | | |

a Distance between power source and load or load decoupling network

b Cable bundle length

NOTE 1 Items 2, 3, and 4 are ancillary equipment, as applicable, and are typically positioned as specified by the equipment manufacturer.

NOTE 2 Insulation (item 9) is placed between items 1 and 3 if specified by the manufacturer.

Figure 1 – Test set-up 1 for arc welding equipment

If due to the design of the arc welding equipment, these tests cannot be carried out as described, the manufacturer's recommendations (for example, temporary bypassing or disabling of control circuits) should be followed in order to match these test objectives. Any temporary changes to the arc welding equipment shall be documented.

If ancillary equipment can be connected to the welding power source, then the welding power source shall be tested with the minimum configuration of ancillary equipment necessary to exercise the ports. If the welding power source has a large number of similar ports or ports with many similar connections, then a sufficient number shall be selected to simulate actual operating conditions and to ensure that all the different types of termination are covered.

For mains terminal voltage disturbance tests the welding power source shall be connected to the electricity supply using the V-network specified in 4.3 whenever possible. The V-network shall be located so that its closest surface is no less than 0,8 m from the nearest boundary of the equipment under test. The input cable shall have a minimum length of 2 m.