

INTERNATIONAL  
STANDARD

**ISO**  
**11530**

First edition  
1993-04-15

---

---

**Road vehicles — Hydraulic jacks —  
Specifications**

**iTeh** *Véhicules routiers — Crics hydrauliques — Spécifications*  
**(standards.iteh.ai)**

ISO 11530:1993

<https://standards.iteh.ai/catalog/standards/sist/b102545c-8559-4834-88c6-a1f6d7763d05/iso-11530-1993>



Reference number  
ISO 11530:1993(E)

## Foreword

ISO (the International Organization for Standardization) is a worldwide federation of national standards bodies (ISO member bodies). The work of preparing International Standards is normally carried out through ISO technical committees. Each member body interested in a subject for which a technical committee has been established has the right to be represented on that committee. International organizations, governmental and non-governmental, in liaison with ISO, also take part in the work. ISO collaborates closely with the International Electrotechnical Commission (IEC) on all matters of electrotechnical standardization.

Draft International Standards adopted by the technical committees are circulated to the member bodies for voting. Publication as an International Standard requires approval by at least 75 % of the member bodies casting a vote.

International Standard ISO 11530 was prepared by Technical Committee ISO/TC 22, *Road vehicles*, Sub-Committee SC 14, *Exterior fittings*.

[ISO 11530:1993](https://standards.iteh.ai/catalog/standards/sist/b102545c-8559-4834-88c6-a1f6d7763d05/iso-11530-1993)

<https://standards.iteh.ai/catalog/standards/sist/b102545c-8559-4834-88c6-a1f6d7763d05/iso-11530-1993>

© ISO 1993

All rights reserved. No part of this publication may be reproduced or utilized in any form or by any means, electronic or mechanical, including photocopying and microfilm, without permission in writing from the publisher.

International Organization for Standardization  
Case Postale 56 • CH-1211 Genève 20 • Switzerland

Printed in Switzerland

# Road vehicles — Hydraulic jacks — Specifications

## 1 Scope

This International Standard specifies design and safety requirements, and test methods for hydraulic jacks for road vehicles, used for changing wheels and putting on chains.

NOTE 1 Although these jacks are primarily designed for use on vehicles with a maximum total calculated mass over 3,5 t, they may still be used on smaller vehicles, e.g. passenger cars which have jacking points specifically designed for the use of such jacks.

## 2 General requirements

**2.1** On delivery, the surfaces shall be protected against corrosion, and all movable parts shall be lubricated, if necessary.

**2.2** Jacks shall be equipped with a suitable means for refilling with hydraulic fluid.

**2.3** The operating force on the handle shall not be greater than 400 N, measured at the end of the handle provided when being operated at the rated load.

**2.4** The ram or cylinder shall be capable of being lowered by a force less than 400 N when the lowering system is operated.

## 3 Safety requirements

**3.1** The head of the jack shall have a rough surface or be designed in such a way as to counteract any tendency of the load to slip off. The projected area of a flat head shall be at least 500 mm<sup>2</sup>, and minimum dimensions in each direction shall normally be 25 mm. Jacks having a mass above 10 kg shall be equipped with a handle to facilitate transportation.

**3.2** Jacks shall be equipped with an over-travel device. Jacks fitted with a height adaptation spindle shall be provided with a spindle travel stop.

**3.3** Jacks shall be equipped with a pressure relief valve adjusted to a pressure corresponding to the rated load, with a tolerance up to +10 %. Some means shall be provided to ensure that this valve is tamper-proof.

**3.4** Jacks shall be designed in such a way that an operator can regulate the lowering speed or stop the lowering at any load up to the rated load.

**3.5** Jacks shall have different operating systems for raising and lowering.

**3.6** The connection between the operating handle and the jack shall be designed so that the handle cannot slip during operation. Similarly, multiple component handles shall be protected against unintentional disassembly.

## 4 Testing

### 4.1 Normal operation conditions

#### 4.1.1 Temperature conditioning

Store jacks at  $(50 \pm 5)$  °C for 24 h, then at  $(-20 \pm 2)$  °C for 24 h, each in the most unfavourable position, as agreed between the supplier and customer. No visible leakage is admissible.

#### 4.1.2 Operation test

Place the jack in its operating position on the test rig shown in figure 1, immediately after each of the conditioning periods in 4.1.1.

The jack shall be able to lift, through the full stroke specified by the manufacturer, the rated load at each of the temperatures.

#### 4.1.3 Static test

Expose the jack to its rated load at nominal full stroke specified by the manufacturer for at least 12 h at a temperature of  $(23 \pm 5)$  °C.

Within this time, a maximum ram movement of 5 mm is admissible, with the measurement starting 5 min after applying the load.

Then lower the ram to half stroke and maintain the load for 30 min. Within this time a maximum ram movement of 2 mm is admissible.

At the end of this test, there shall be no oil leakage.

#### 4.1.4 Pressure relief valve

Expose the jack to its rated load plus 15 %.

The jack shall not be capable of lifting this load.

#### 4.1.5 Durability

Jacks shall be capable of lifting, stopping and lowering the rated load 50 times over the full stroke at a temperature of  $(23 \pm 5)$  °C with the height adaptation spindle turned to the lowest position.

Between each lift, pause for 5 min. After the last raising and maintaining the rated load for 2 min, check the height. This shall be equal to the nominal full stroke specified by the manufacturer.

This test shall be carried out in accordance with figure 1. Lubrication after 10 strokes is allowed.

#### 4.1.6 Test of over-travel device

Operate the jack with a load of 25 % of its rated load, until the over-travel device operates.

No permanent deformation of any part is admissible. No seal failures are admissible.

#### 4.2 Modified operating conditions

For the following two tests, a new sample jack may be used in which the pressure relief valve shall be neutralized.

**4.2.1** Expose the jack positioned vertically to a vertical load 15 % higher than the rated load. Under this condition, with the height adaptation spindle turned to the highest position, it shall be possible to lift the load, to stop it for 15 min and to lower it.

No permanent deformation of any part affecting normal use is admissible.

At the end of this test, there shall be no oil leakage.

**4.2.2** Expose the jack positioned vertically to a vertical load 50 % higher than the rated load for 15 min, with the ram at half stroke, and the height adaptation spindle turned to the mid-point position.

No permanent deformation affecting normal work is admissible.

At the end of this test, there shall be no oil leakage.

### 5 Use and maintenance instructions

**5.1** Written instructions for safety, use, maintenance and hydraulic fluid characteristics shall be provided by the jack manufacturer or the vehicle manufacturer.

**5.2** Special recommendations shall be given as to how to apply the jack at the proper lifting points indicated by the vehicle manufacturer.

### 6 Marking

Each jack shall be durably marked with

- a) the name or trademark of the manufacturer or supplier;
- b) the year of manufacture;
- c) its type;
- d) instructions for safe use of the jack.

In addition, the rated load (and nominal stroke) shall be marked in a clearly legible manner.

Dimensions in millimetres

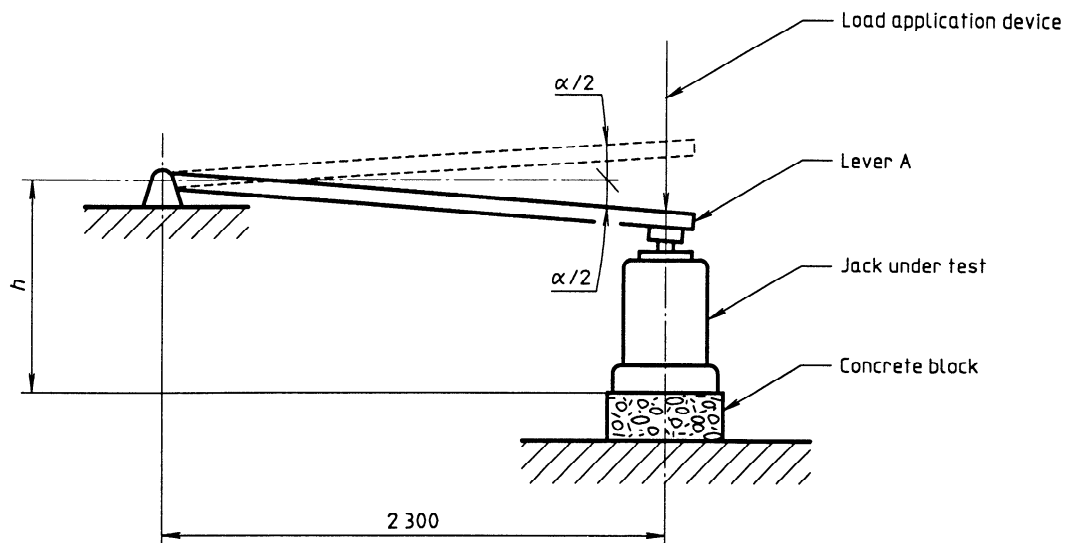

## NOTES

- 1 Lever A is intended to simulate the travel of the axle to be lifted. Dimension  $h$  shall be adjusted in order that lever A is horizontal when the jack is in the middle of its stroke.
- 2 The area on lever A where the head of the jack is applied shall have a hardness of at least 285 HB and a surface roughness of  $R_a 6,3 \mu\text{m}$ , to avoid slipping off.

(standards.iteh.ai)

Figure 1 — Test rig

ISO 11530:1993

<https://standards.iteh.ai/catalog/standards/sist/b102545c-8559-4834-88c6-a1f6d7763d05/iso-11530-1993>

<https://standards.iteh.ai/catalog/standards/sist/b102545c-8559-4834-88c6-a16d7763d05/iso-11530-1993>  
This page intentionally left blank

**!Teh STANDARD PREVIEW**  
**(standards.iteh.ai)**

ISO 11530-1993  
https://standards.iteh.ai/catalog/standards/sist/b102545c-8559-4834-88c6-  
a1f6d7763d05/iso-11530-1993

This page intentionally left blank

**!Teh STANDARD PREVIEW**  
**(standards.iteh.ai)**

**iTeh STANDARD PREVIEW**  
**(standards.iteh.ai)**

ISO 11530:1993

<https://standards.iteh.ai/catalog/standards/sist/b102545c-8559-4834-88c6-a1f6d7763d05/iso-11530-1993>

---

---

**UDC 629.11.012.73**

**Descriptors:** road vehicles, lifting equipment, jacks (lifts), specifications, safety requirements, tests, marking.

Price based on 3 pages

---

---