

INTERNATIONAL
STANDARD

ISO
11531

First edition
1994-04-15

Metallic materials — Earing test

Matériaux métalliques — Essai de corne
iTeh STANDARD PREVIEW
(standards.iteh.ai)

ISO 11531:1994

<https://standards.iteh.ai/catalog/standards/sist/a6d2c3fa-9b96-4a32-86d3-807539d2559c/iso-11531-1994>



Reference number
ISO 11531:1994(E)

Foreword

ISO (the International Organization for Standardization) is a worldwide federation of national standards bodies (ISO member bodies). The work of preparing International Standards is normally carried out through ISO technical committees. Each member body interested in a subject for which a technical committee has been established has the right to be represented on that committee. International organizations, governmental and non-governmental, in liaison with ISO, also take part in the work. ISO collaborates closely with the International Electrotechnical Commission (IEC) on all matters of electrotechnical standardization.

Draft International Standards adopted by the technical committees are circulated to the member bodies for voting. Publication as an International Standard requires approval by at least 75 % of the member bodies casting a vote.

International Standard ISO 11531 was prepared by Technical Committee ISO/TC 164, *Mechanical testing of metals*, Subcommittee SC 2, *Ductility testing*.

<https://standards.iteh.ai/catalog/standards/sist/a6d2c3fa-9b96-4a32-86d3-807539d2559c/iso-11531-1994>

© ISO 1994

All rights reserved. Unless otherwise specified, no part of this publication may be reproduced or utilized in any form or by any means, electronic or mechanical, including photocopying and microfilm, without permission in writing from the publisher.

International Organization for Standardization
Case Postale 56 • CH-1211 Genève 20 • Switzerland

Printed in Switzerland

Metallic materials — Earing test

1 Scope

This International Standard specifies a method for determining the ear height of metal sheet and strip of nominal thickness from 0,1 mm to 3 mm after deep drawing.

2 Normative references

The following standards contain provisions which, through reference in this text, constitute provisions of this International Standard. At the time of publication, the editions indicated were valid. All standards are subject to revision, and parties to agreements based on this International Standard are encouraged to investigate the possibility of applying the most recent editions of the standards indicated below. Members of IEC and ISO maintain registers of currently valid International Standards.

ISO 468:1982, *Surface roughness — Parameters, their values and general rules for specifying requirements*.

ISO 6507-1:1982, *Metallic materials — Hardness test — Vickers test — Part 1: HV 5 to HV 100*.

3 Symbols and their meanings

The meanings of the symbols used in the earing test are given in table 1 and illustrated in figures 1 and 2.

Table 1

Symbol	Meaning	Units
a	Thickness of test piece	mm
d_1	Diameter of punch	mm
R_1	Corner radius of punch	mm
d_2	Inside diameter of die	
R_2	Inside corner radius of die	mm
d_b	Diameter of circular blank	mm
h_t	Distance between outside bottom of cup and any ear peak	mm
h_v	Distance between outside bottom of cup and any ear valley	mm
$h_{t,max}$	Maximum value of h_t	mm
$h_{v,min}$	Minimum value of h_v	mm
\bar{h}_t	Mean value of h_t	mm
\bar{h}_v	Mean value of h_v	mm
\bar{h}_e	Mean ear height	mm
$h_{e,max}$	Maximum ear height	mm
Z	Ear height expressed as a percentage	%
R_a	Surface roughness parameter: arithmetic mean deviation of profile	μm

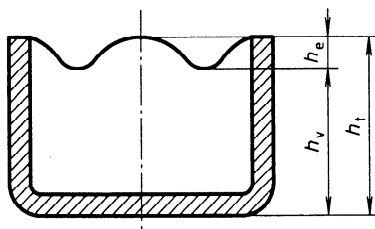

Figure 1 — Schematic section of cup

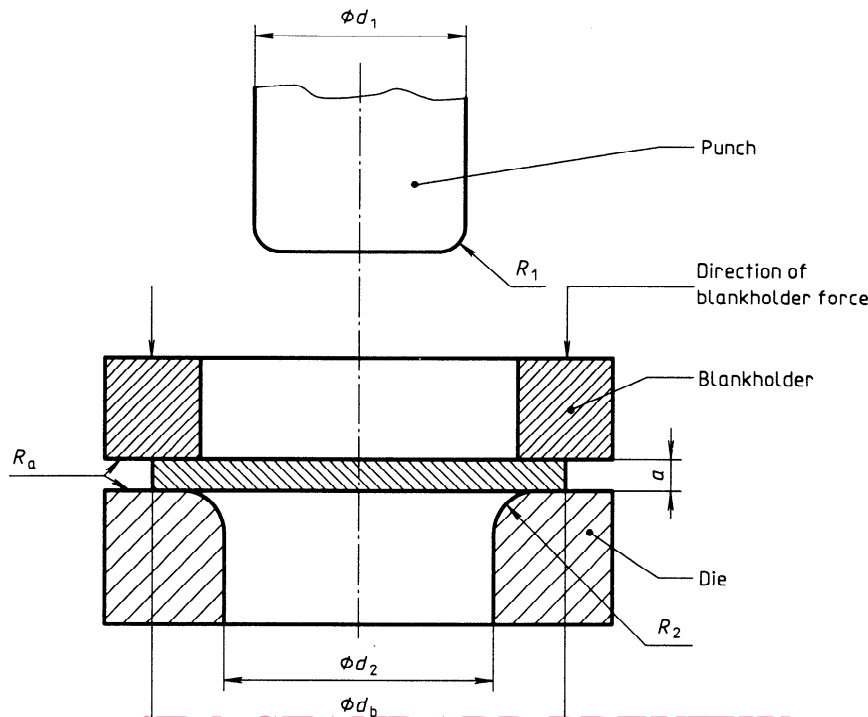

Figure 2 — Schematic diagram of test equipment

4 Principle

Cylindrical cups are drawn from circular blanks taken from metal sheets or strips, and the height of any earing produced by this process is measured.

5 Test equipment

5.1 The general arrangement of the test equipment is given in figure 2. The punch shall be capable of moving along the central axis of the die and blankholder and the blank. The equipment shall be such that ironing of ears due to the blankholder force and/or due to insufficient clearance between the punch and die is avoided and such that the cup can be removed without damaging the ears.

5.2 The machine shall be capable of controlling the speed of drawing and the blankholder force.

5.3 The machine shall be equipped with a device for positioning the blank concentrically with the central axis of the machine.

NOTE 1 The blank-positioning device is not required if the blank is produced as part of the cup-forming process.

5.4 The dimensions of the punch and die shall be chosen as a function of the sheet thickness in accordance with table 2, unless otherwise specified in the product standard or by agreement.

NOTE 2 The punch and die dimension combinations given in table 2 are general and may not be ideal for all materials due to the influence of the clearance between the punch and die. It is recommended that the product standard specify the combinations required for each product.

5.5 The die, the blankholder and the punch shall be sufficiently rigid not to deform appreciably during the test. The Vickers hardness of the working surfaces of the die, the blankholder and the punch shall be at least 750 HV 30. The surfaces of the die, the blankholder and the punch, which contact the test piece shall be polished. The roughness value R_a of the surfaces shall be in accordance with table 2.

Table 2

Thickness of test piece a mm	Inside diameter of die d_2		Inside radius of die R_2		Surface roughness (maximum) R_a μm
	for $d_1 = 33$ mm	for $d_1 = 50$ mm	for $d_1 = 33$ mm	for $d_1 = 50$ mm	
$0,1 < a \leq 0,2$	33,44	50,44	$2,0 \begin{smallmatrix} 0 \\ -0,2 \end{smallmatrix}$	$2,5 \begin{smallmatrix} 0 \\ -0,2 \end{smallmatrix}$	0,1
$0,2 < a \leq 0,4$	33,88	50,88	$2,5 \begin{smallmatrix} +0,2 \\ 0 \end{smallmatrix}$	$3,0 \begin{smallmatrix} +0,2 \\ 0 \end{smallmatrix}$	0,1
$0,4 < a \leq 0,8$	34,76	51,76	$3,5 \begin{smallmatrix} +0,2 \\ 0 \end{smallmatrix}$	$4,5 \pm 0,1$	0,8
$0,8 < a \leq 1,6$	36,52	53,52	$5,0 \begin{smallmatrix} +0,2 \\ 0 \end{smallmatrix}$	$6,5 \pm 0,1$	0,8
$1,6 < a \leq 3,0$	39,60	56,60	$7,0 \begin{smallmatrix} +0,2 \\ 0 \end{smallmatrix}$	$9 \begin{smallmatrix} 0 \\ -0,2 \end{smallmatrix}$	1,6

Punch radius R_1 will be $3,3 \text{ mm} \pm 0,05 \text{ mm}$ for punch diameter of 33 mm, and $5,0 \text{ mm} \pm 0,05 \text{ mm}$ for punch diameter 50 mm.

6 Test piece

6.1 Circular blanks are used as test pieces. The drawing ratio, i.e. the ratio of blank diameter to punch diameter, shall be as large as possible without any risk of tearing at the bottom of the cup. For a test series or comparative tests, the same drawing ratio shall be the same in all cases. A drawing ratio of 1,8 has been found satisfactory.

6.2 The test piece shall be free of burrs on the edges which would interfere with the test.

6.3 Before testing, the test piece shall not be subjected to any hammering or hot or cold working.

7 Procedure

7.1 In general, the test shall be carried out at ambient temperature within the limits of $10 \text{ }^\circ\text{C}$ and $35 \text{ }^\circ\text{C}$. Tests performed under controlled conditions shall be carried out at a temperature of $23 \text{ }^\circ\text{C} \pm 5 \text{ }^\circ\text{C}$.

7.2 Determine the thickness of the test piece to the nearest 0,01 mm and select the appropriate punch and die in accordance with 5.4.

7.3 Before testing, coat the two faces of the test piece lightly and uniformly with lubricant as specified in the relevant standard or by agreement. The lubricant will depend on the nature of the material.

7.4 Position the blank concentrically between the blankholder and the die. Apply the blankholder force that is just sufficient to prevent wrinkling of the flange.

NOTE 3 If it is not known what blankholder force is required to achieve this, it will have to be found by trial and error. The following values are provided for guidance for the first attempt:

Diameter of punch (mm)	Aluminium	Steel
33	1 000 N	2 000 N
50	2 000 N	4 000 N

(See also 5.1)

7.5 Bring the punch into contact with the test piece and form the cup without a flange.

7.6 All non-concentric cups and those having irregular deformations or other faults shall be rejected.

7.7 Measure the height of each ear peak h_t and each ear valley h_v on the cup with an accuracy of $\pm 0,05 \text{ mm}$.

7.8 Record the orientation of the ears with respect to the direction of rolling of the sheet.

8 Interpretation of results

From the measurements made, the following parameters can be determined.

8.1 Mean value of the ear peak h_t and the ear valley h_v :

$$\bar{h}_t = \frac{h_{t1} + h_{t2} + h_{t3} + \dots}{\text{Number of ear peaks}}$$

$$\bar{h}_v = \frac{h_{v1} + h_{v2} + h_{v3} + \dots}{\text{Number of ear valleys}}$$

8.2 Mean ear height:

$$\bar{h}_e = \bar{h}_t - \bar{h}_v$$

8.3 Maximum ear height:

$$h_{e,\max} = h_{t,\max} - h_{v,\min}$$

8.4 Ear height expressed as a percentage:

$$Z = \frac{\bar{h}_e}{h_v} \times 100$$

9 Test report

9.1 The test report shall include the following information:

- a reference to this International Standard;
- all details necessary for identification of the test piece;
- the thickness and diameter of the blank;
- the diameter of the punch and that of the die;
- the punch speed;
- the number of ears and their orientation;
- the results from clause 8 as required by the relevant standard or by agreement.

9.2 The test report may also include the following information:

- the blankholder force;
- the type of lubricant used;
- the non-mandatory results from clause 8.

iTeh STANDARD PREVIEW
(standards.iteh.ai)

ISO 11531:1994

<https://standards.iteh.ai/catalog/standards/sist/a6d2c3fa-9b96-4a32-86d3-807539d2559c/iso-11531-1994>

iTeh STANDARD PREVIEW

This page intentionally left blank
(standards.iteh.ai)

ISO 11531:1994

<https://standards.iteh.ai/catalog/standards/sist/a6d2c3fa-9b96-4a32-86d3-807539d2559c/iso-11531-1994>

iTeh STANDARD PREVIEW
(standards.iteh.ai)

ISO 11531:1994

<https://standards.iteh.ai/catalog/standards/sist/a6d2c3fa-9b96-4a32-86d3-807539d2559c/iso-11531-1994>

ICS 77.040.10

Descriptors: metallurgical products, metal drawing, cupping, tests, mechanical tests, cupping tests.

Price based on 4 pages
