



Standard Practice for Fabrication of Fiberboard Shipping Boxes¹

This standard is issued under the fixed designation D 5118/D 5118M; the number immediately following the designation indicates the year of original adoption or, in the case of revision, the year of last revision. A number in parentheses indicates the year of last reapproval. A superscript epsilon (ϵ) indicates an editorial change since the last revision or reapproval.

1. Scope

1.1 This practice covers the fabrication of new fiberboard boxes, liners and sleeves.

1.2 This practice points out the factors and components that must be controlled in the manufacture of corrugated and solid fiberboard boxes, liners and sleeves.

1.3 This practice does not cover the adequacy of fiberboard containers under all conditions of exposure to atmosphere, handling, shipping and storage.

1.4 The values stated in either inch-pound units or SI units are to be regarded separately as standard. Within the text, the SI units are shown in brackets. The values stated in each system are not exact equivalents; therefore, each system must be used independently of the other. Combining values from the two systems may result in non-conformance with the standard.

1.5 *This standard does not purport to address all of the safety concerns, if any, associated with its use. It is the responsibility of the user of this standard to establish appropriate safety and health practices and determine the applicability of regulatory limitations prior to use.*

2. Referenced Documents

2.1 ASTM Standards:

D 685 Practice for Conditioning Paper and Paper Products for Testing²

D 996 Terminology of Packaging and Distribution Environments²

D 3950 Specification for Strapping, Nonmetallic (and Joining Methods)²

D 3951 Practice for Commercial Packaging²

D 3953 Specification for Strapping, Flat Steel and Seals²

D 4727 Specification for Corrugated and Solid Fiberboard Sheet Stock (Container Grade) and Cut Shapes²

2.2 Federal Specifications:³

MMM-A-250 Adhesives, Water-Resistant (For Closure of Fiberboard Boxes)

PPP-B-638 Packing of Boxes, Caps, Liners, and Sleeves

FED-STD-123 Marking for Shipment (Civil Agencies)

MIL-STD-129 Marking for Shipment and Storage

2.3 *Code of Federal Regulations:*³

Title 49

2.4 *Other Publications:*

National Motor Freight Classification⁴

Uniform Freight Classification⁵

Federal Food, Drug and Cosmetic Act⁶

3. Terminology

3.1 Definitions of terms relating to packaging are found in Terminology D 996.

4. Significance and Use

4.1 Corrugated and solid fiberboard boxes, sleeves and liners are used to unitize products into packages of size and shape suitable for manual or mechanical handling and to protect the contents against environmental, handling, shipping, and storage conditions.

4.2 This practice covers some of the basic constructions and styles of commercially available fiberboard packaging used to unitize and protect contents.

4.3 *Use of Other Specifications*—Nothing in this practice shall be construed to prohibit the use of boxes of special design or of fiberboard packages identified by package number in the current Uniform Freight Classification and National Motor Freight Classification when in the experience and judgement of the purchaser, the nature of the articles or material to be shipped justifies such boxes or packages. Some commodities may require less protection while other commodities may require better boxes than are specified herein. Containers for explosives and dangerous articles must also comply with regulations for the Transport of Hazardous Materials (CFR Title 49).

¹ This practice is under the jurisdiction of ASTM Committee D-10 on Packaging and is the direct responsibility of Subcommittee D10.27 on Paper and Paperboard Products.

Current edition approved Nov. 10, 1995. Published March 1996. Originally published as D 5118/D 5118M – 90. Last previous edition D 5118/D 5118M – 90.

² *Annual Book of ASTM Standards*, Vol 15.09.

³ Available from Standardization Documents, Order Desk, Bldg. 4, Section D, 700 Robbins Ave., Philadelphia, PA 19111-5094, attn: NPODS.

⁴ Available from National Motor Freight Classification, Inc., 2200 Mill Road, Alexandria, VA 22314.

⁵ Available from National Railroad Freight Committee, Suite 1120, 222 Riverside Plaza, Chicago, IL 60606.

⁶ Available from the Superintendent of Documents, US Government Printing Office, Washington, DC 20402.

5. Styles

5.1 Fiberboard boxes covered by this practice may be of the following styles:

- 5.1.1 RSC/0201⁷—Regular slotted box (Fig. 1).
 - 5.1.2 OSC/0202⁷—Overlap slotted box (Fig. 2).
 - 5.1.3 FOL/0203⁷—Full overlap slotted box (Fig. 3).
 - 5.1.4 SFF/0206⁷—Special full flap slotted box (Fig. 4).
 - 5.1.5 CSSC/0204⁷—Center special slotted box (Fig. 5).
 - 5.1.6 CSOSC/0205⁷—Center special overlap slotted box (Fig. 5).
 - 5.1.7 HSCC/0312⁷—Half slotted box with cover (Fig. 6).
 - 5.1.8 DBLCC/0310⁷—Double cover box (Fig. 7).
 - 5.1.9 IC/0325⁷—Interlocking double cover box (Fig. 8).
 - 5.1.10 FTC/0301⁷—Full telescope box (Fig. 9).
 - 5.1.11 FTHS/0320⁷—Full telescope half slotted box (Fig. 10).
 - 5.1.12 OPF/0401⁷—One piece folder (Fig. 11).
 - 5.1.13 FPF/0410⁷—Five panel folder (Fig. 12).
 - 5.1.14 TS—Triple slide box (type CF only) (Fig. 13).
 - 5.1.15 TSC—Tongue and slot closure box (Fig. 14).
- 5.2 Other styles may also be applicable (see 8.1.3).

6. Requirements

6.1 Materials:

⁷ Available from European Federation of Manufacturers of Corrugated Board (FEFCO), 37 Rue d'Amsterdam, 75008, Paris, France. Also known as the International Box Code System, that is, in RSC/0201, RSC stands for regular slotted container and 0201 is the international box code number for the RSC.

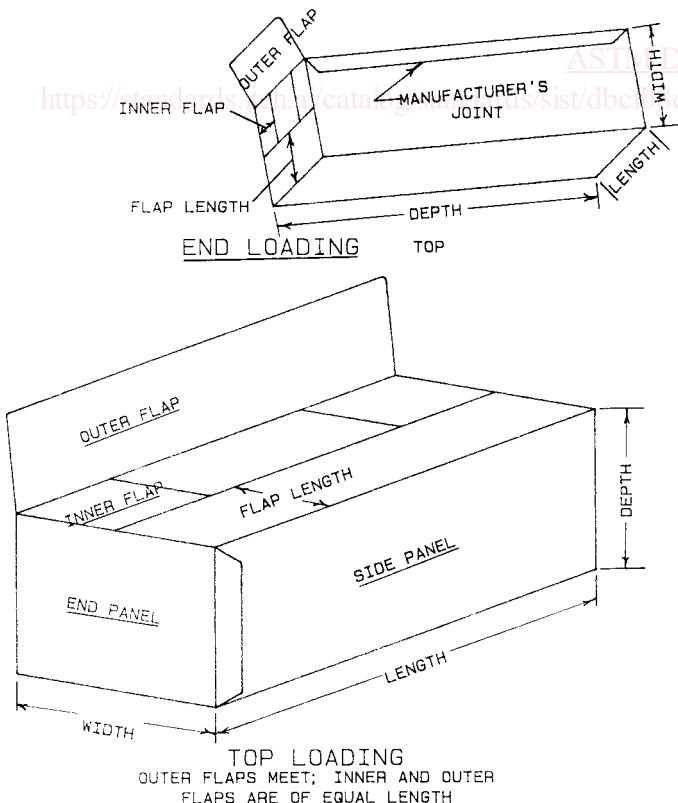

FIG. 1 Box, Fiberboard; RSC—Regular Slotted Box

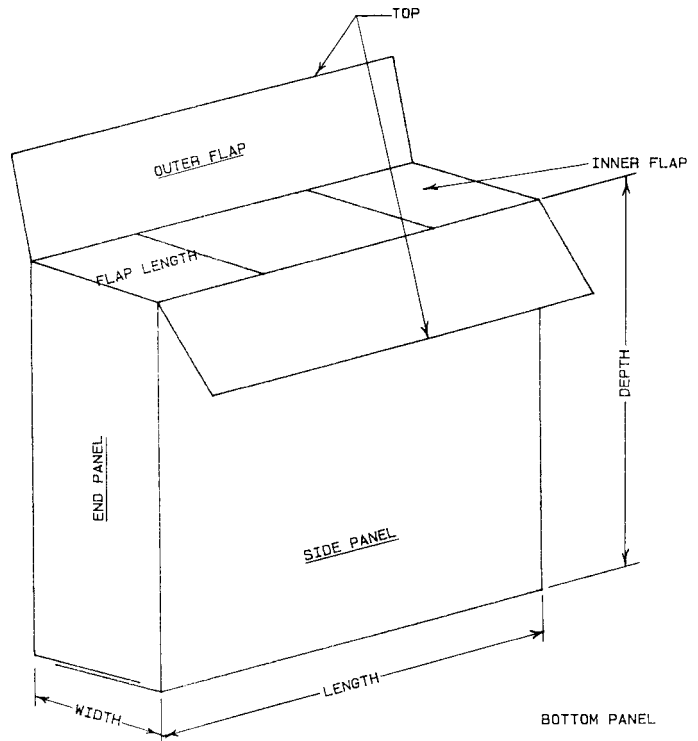

FIG. 2 Box, Fiberboard; OSC—Overlap Slotted Box

6.1.1 Fiberboard shall conform to type, class, variety, and grade of Specification D 4727 unless otherwise specified. Flute structure shall be as specified in Specification D 4727 (see 8.1.2).

6.1.2 Manufacturer's joints shall be secured by one of the following materials: (The joint is that seam of a box where the ends of the box blank are joined.)

6.1.2.1 Metal fasteners shall be commercially preformed staples or staples formed from commercial steel stitching wire. All metal fasteners shall have commercially applied coating of zinc or copper wash.

6.1.2.2 Manufacturer's joint tapes shall be of the following constructions:

(1) For boxes not exceeding 65 lb [30 kg] gross weight sealing strips must not be less than 2 in. [51 mm] wide, and must comply with one of the following requirements:

(a) Two thicknesses of sulphate paper, total basis weight not less than 80 lb [130 g/m²] combined with a water-resistant compound and reinforced with not less than double strand nylon fiber not less than 210 denier forming a pattern with strands not more than 1/2 in. [13 mm] apart.

(b) Cloth having crosswise (filler) threads having a minimum tearing strength of 40 Elemendorf units. Inside and outside strips of sulphate paper not less than 2 in. [51 mm] wide; outside strip having a basis weight of not less than 60 lb [100 g/m²] having a bursting strength of not less than 60 psi [414 kPa]; inside strip having a basis weight not less than 40 lb [65 g/m²], and a bursting strength of not less than 40 psi [275 kPa].

(2) For boxes exceeding 65 lb [30 kg] gross weight, sealing

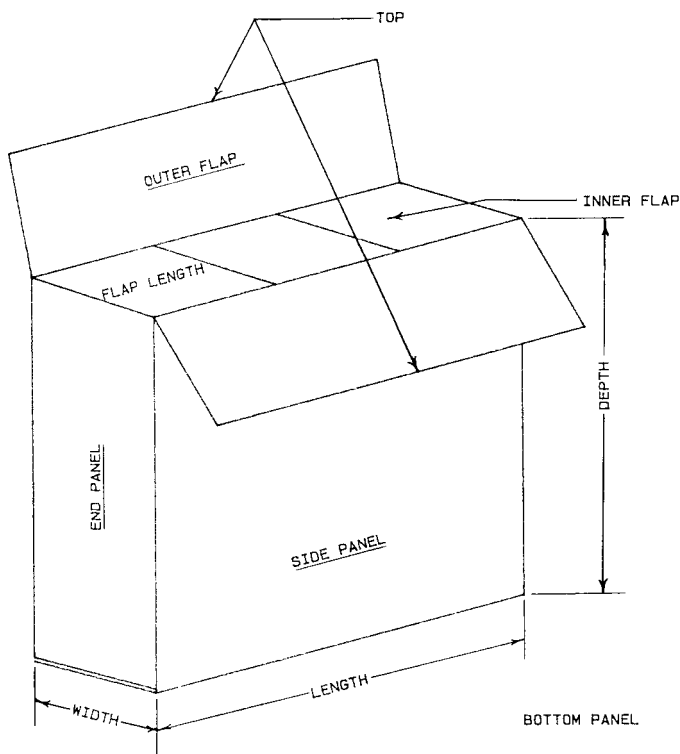

OUTER FLAPS FULL OVERLAP (SEE DETAIL REQUIREMENTS)
INNER FLAPS SAME LENGTH AS OUTER FLAPS

FIG. 3 Box, Fiberboard; FOL—Full Overlap Slotted Box

strips must be not less than 3 in. [76 mm] wide, unless otherwise provided, and must comply with one of the following requirements:

(a) One thickness of sulphate paper, the fibers of which are integrally bonded and reinforced with rubber, basis weight not less than 175 lb [285 g/m²], embossed and varnished. Two thicknesses of sulphate paper, total basis weight not less than 80 lb [130 g/m²], reinforced in the cross direction with alternating bands of 840 denier and 420 denier nylon, not less than 4 bands every 2 in. [51 mm]. One thickness of sulphate paper having a basis weight not less than 70 lb [114 g/m²] reinforced in the cross direction with alternating bands of 840 denier and 420 denier nylon, not less than 4 bands every 2 in. [51 mm], nylon bands firmly adhered to the surface of the paper by means of a water-resistant compound.

NOTE 1—Kraft tape basis weights are calculated as a ream weight of 500 sheets of 24 in. [610 mm] by 36 in. [915 mm] paper. The base stocks are 90 lb [41 kg], 120 lb [55 kg] or 140 lb [64 kg] kraft ream weight. These convert to 30 lb/1000 ft² [150 g/m²], 40 lb/1000 ft² [195 g/m²], and 47 lb/1000 ft² [230 g/m²] kraft liner board equivalents.

(b) Two thicknesses of sulphate paper, total basis weight not less than 80 lb [130 g/m²] combined with a water-resistant compound and with reinforcing as follows:

- Asphalt reinforced with sisal fibers.
- With glass, rayon, or glass and rayon fibers combined, running crosswise of tape not more than 3/8 in. [10 mm] apart, the rayon fibers to be not less than 1100 denier.
- With glass fibers in a diamond pattern the sides of which, parallel to each other, are formed by a cluster of yarn not less than two per inch as measured in the machine direction. Each

cluster shall be formed of at least two 150-1/0 threads or the equivalent in weight of 75-1/0 yarn.

(c) Two thicknesses of sulphate paper, one 30 lb [50 g/m²] basis weight and the other 60 lb [98 g/m²] basis weight reinforced with cotton or linen fibers

(d) Two or more thicknesses of sulphate paper, total basis weight not less than 150 lb [244 g/m²] and having a bursting strength of not less than 150 psi [1034 kPa], all plies firmly glued together not less than 1/4 in. [6 mm] wide along both edges. Cloth having crosswise (filled) threads having a minimum tearing strength of 70 Elemendorf units. Inside and outside strips of sulphate paper not less than 2 in. [50.0 mm] wide, each having a basis weight not less than 90 lb [147 g/m²], and having a bursting strength of not less than 90 psi [621 kPa].

6.1.2.3 *Cold adhesive* shall conform to MMM-A-250 and as specified herein. When boxes are used for packaging or packing food and the adhesive used may contact or be in proximity to the food, the adhesive shall comply with the Federal Food, Drug and Cosmetic Act and regulations promulgated thereunder.

6.1.2.4 *Hot melt adhesives* can be used when gross weight does not exceed 65 lb [30 kg], by overlapping the sides of box forming the joint not less than 1 1/4 in. [32 mm] and by firmly gluing this joint with hot melt adhesive consisting of 100 % solids contents of thermal-plastic materials, which will maintain bond at temperatures ranging from -20°F [-29°C] to +165°F [+74°C] above zero.

6.2 Boxes shall be designed for type, class, variety, and grade as set forth in Specification D 4727, Tables 1 and 2, and styles specified herein (see 5.1, 5.2 and 6.2.1).

6.2.1 *Style:*

6.2.1.1 The style of box or folder shall be as specified (see 8.1.3). The location of the openings shall be determined by the specified dimensions, which shall always be furnished in the order of length, width, and depth (see 6.3 and Fig. 1 and Fig. 15).

6.2.1.2 *Regular Slotted (RSC/0201)*—This box shall meet the requirements of Fig. 1. The box shall be scored and slotted to form a body piece having four flaps for closing each of two opposite faces. The flaps along the longer edge of the box openings are the outer flaps and those along the shorter edge are the inner flaps. Flaps shall not project beyond an edge of the box. All flaps shall be of equal length with the outer flaps meeting in the center of the width panel but shall not overlap. The gap not to exceed 1/4 in. [6 mm] will be permitted unless otherwise specified.

6.2.1.3 *Overlap Slotted (OSC/0202)*—This box shall meet the requirements of Fig. 2. This box shall be scored and slotted to form a body piece having four flaps for closing each of two opposite faces. When closed, the inner flaps shall not overlap and the outer flaps shall overlap the distance specified (see 8.1.9). Inner flaps shall be the same length as the outer flaps, except where the relation of width to length would cause the inner flaps to overlap, in which case, the inner flaps shall be cut so that, when in closed position, they shall meet.

6.2.1.4 *Full Overlap Slotted (FOL/0203)*—This box shall meet the requirements of Fig. 3. The box shall be constructed in accordance with 6.2.1.3, except that the length of the outer

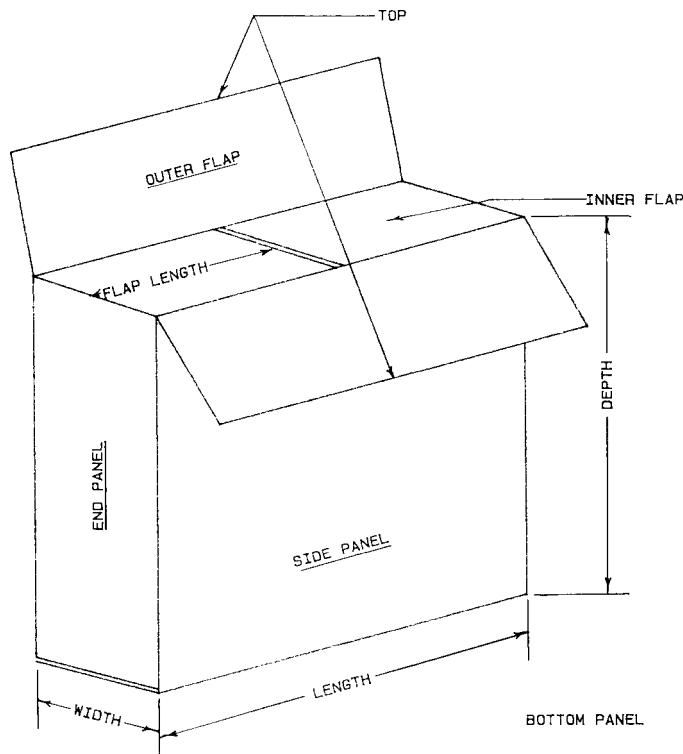

OUTER FLAPS FULL OVERLAP
(SEE DETAIL REQUIREMENTS)
INNER FLAPS MEET IN CENTER

FIG. 4 Box, Fiberboard; SFF—Special Full Flap Slotted Box

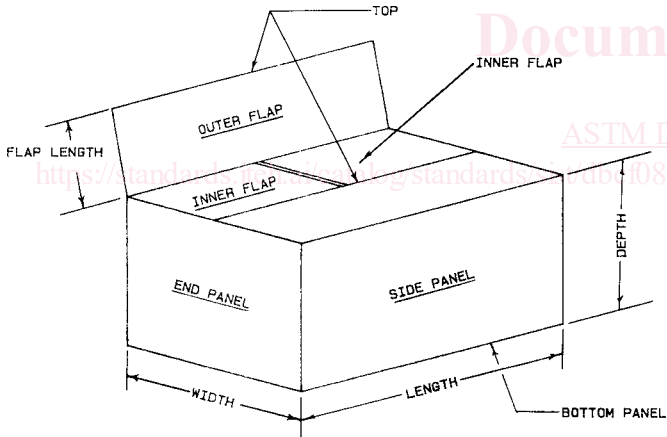

| | |
|---------------------------|-------|
| OUTER FLAPS MEET | CSOSC |
| INNER FLAPS MEET | CSOSC |
| OUTER FLAPS OVERLAP | CSOSC |
| AT RANDOM NO FLAP CUTTING | CSOSC |
| INNER FLAPS MEET | CSOSC |

FIG. 5 Box, Fiberboard; CSSC—Center Special Slotted Box and CSOSC—Center Special Overlap Slotted Box

flaps shall be the full width of the box and shall not extend beyond the edge of the box (see 6.6).

6.2.1.5 *Special Full Flap Slotted (SFF/0206)*—This box

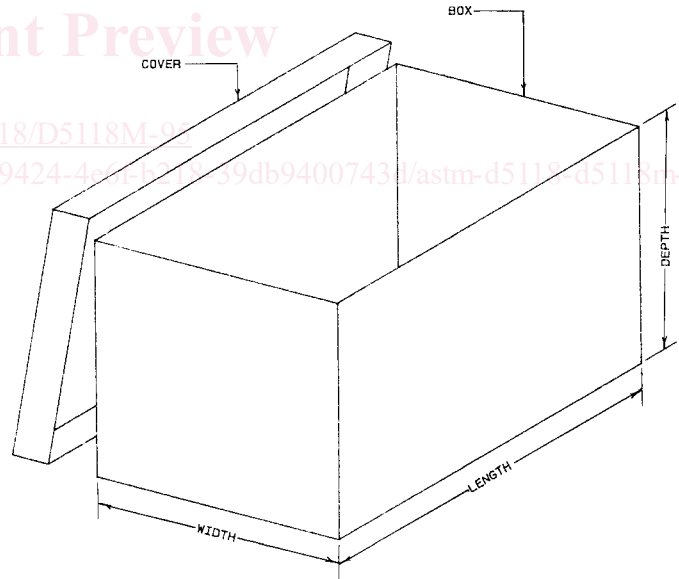

FIG. 6 Box, Fiberboard; HSCC—Half Slotted Box with Cover

shall meet the requirements of Fig. 4. This box shall be constructed in accordance with 6.2.1.3, except that the length of the inner flaps in the closed position shall be such that they meet in the center of the box but do not overlap. A gap not to exceed 1/4 in. [6 mm] will be permitted.

6.2.1.6 *Center Special Slotted (CSSC/0204)*— This box shall meet the requirements of Fig. 5. The box shall be constructed in accordance with 6.2.1.2, except that the length

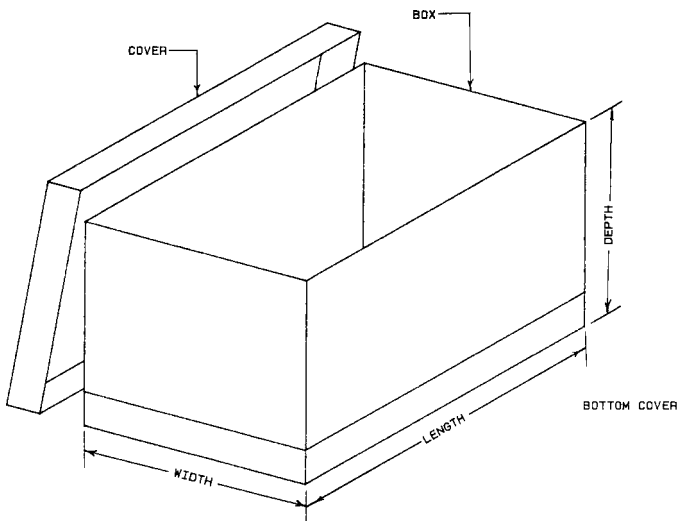
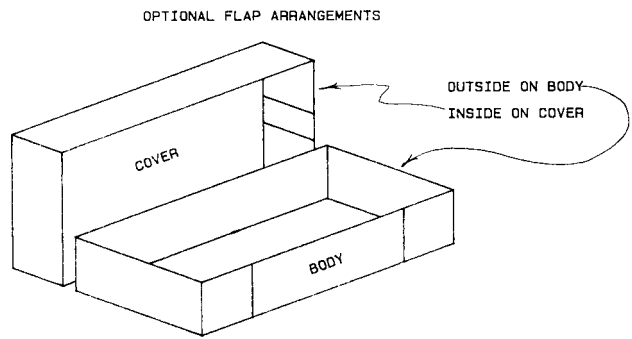

FIG. 7 Box, Fiberboard; DBLCC—Double Cover



NOTE - UNLESS OTHERWISE SPECIFIED, COVER DEPTH SHALL EQUAL OVER-ALL OUTSIDE HEIGHT OF BODY; & BODY SLOTTING SHALL BE AT RIGHT ANGLES TO COVER SLOTTING

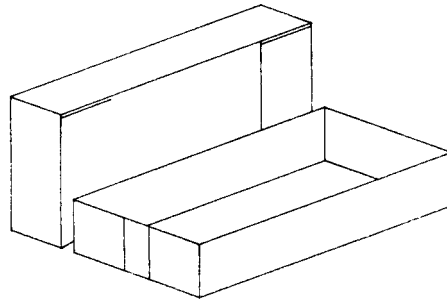

FIG. 9 Box, Fiberboard; FTC—Full Telescope

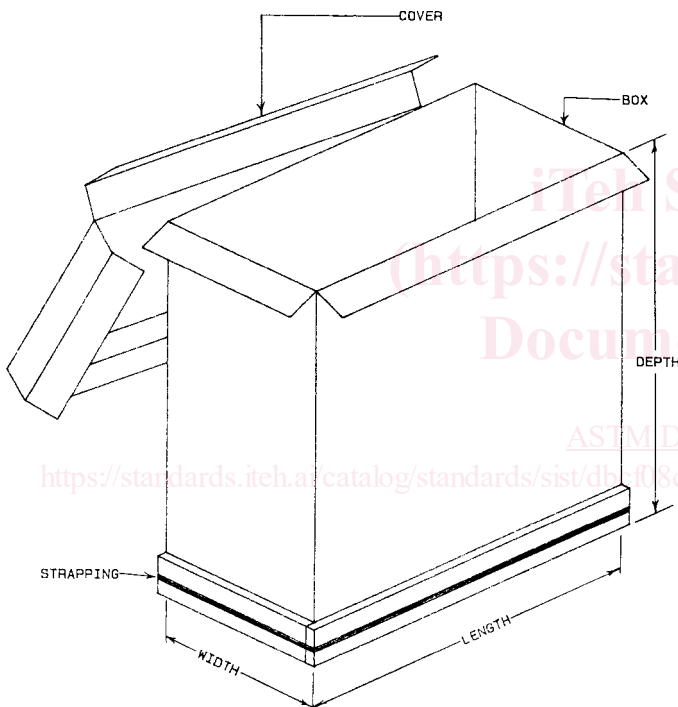

FIG. 8 Box, Fiberboard; IC—Interlocking Double Cover

of the inner and outer flaps shall be such that they meet in the center of the box but do not overlap. A gap not to exceed 1/4 in. [6 mm] will be permitted.

6.2.1.7 *Center Special Overlap Slotted (CSOCS/0205)*—(See Fig. 5.) This box shall be as specified herein. When closed, the inner flaps shall meet in the middle of the face with a gap not to exceed 1/4 in. [6.4 mm] when in the closed position. Outer flaps shall be the same length as the inner flaps and may overlap (no flap cutting is required). Dimension of the box shall be such that the outer flaps do not extend beyond the configuration of the box.

6.2.1.8 *Half Slotted With Cover (HSCC/0312)*—This box shall meet the requirements of Fig. 6. The box consists of a box body and a cover. The body shall be scored, slotted and secured

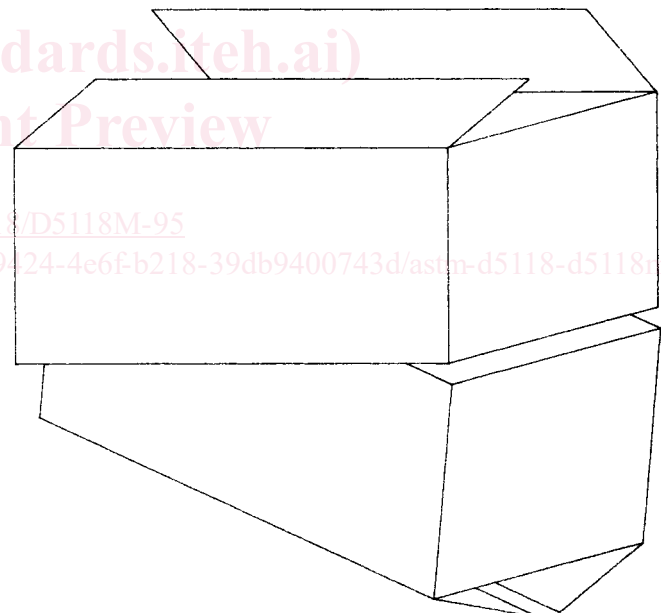

FIG. 10 Box, Fiberboard; FTHS—Two Piece Full Telescope Half Slotted Box

to form a tube having four flaps, of equal length on the bottom. The outer flaps shall meet when closed with a gap not to exceed 1/4 in. [6.4 mm]. Unless otherwise specified, the cover shall be a Type I (see Fig. 16) stitch locked cover. When specified (see 8.1.10), the cover shall be Type II (see Fig. 16). Unless otherwise specified, (see 8.1.11 and 8.1.12) the cover depth shall be 3 in. [76 mm] and shipped unassembled. The body may be used as an HSC alone.

6.2.1.9 *Double Cover (DBLCC/0310)*—This box shall meet the requirements of Fig. 7. The box consists of a body tube and

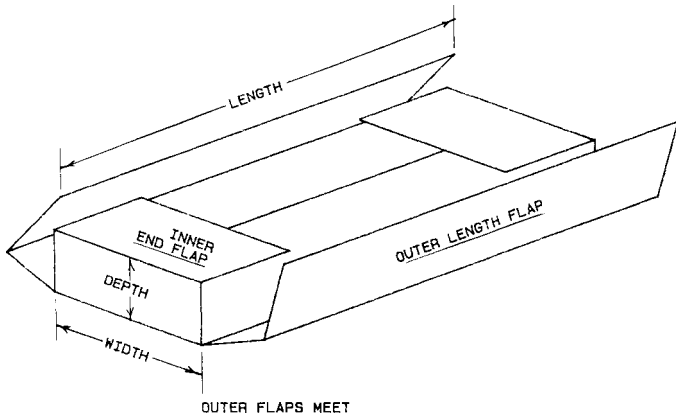

FIG. 11 Folder; Fiberboard; OPF—One Piece Folder

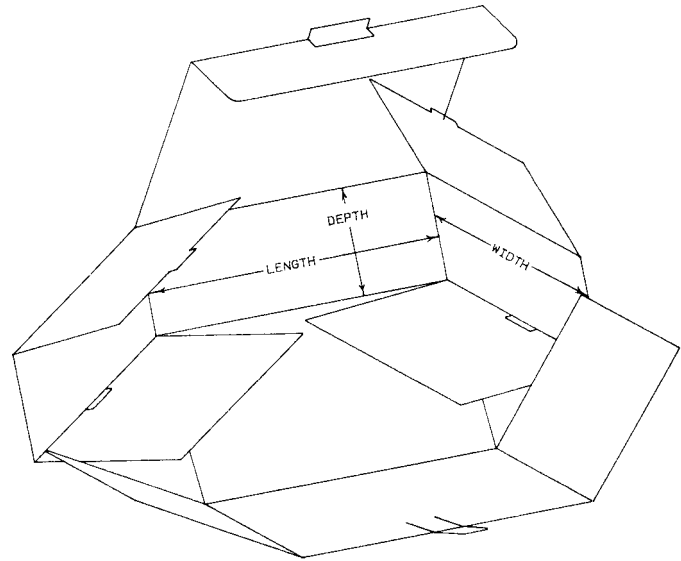

FIG. 14 Folder, Fiberboard; TSC—Tongue and Slot Closure

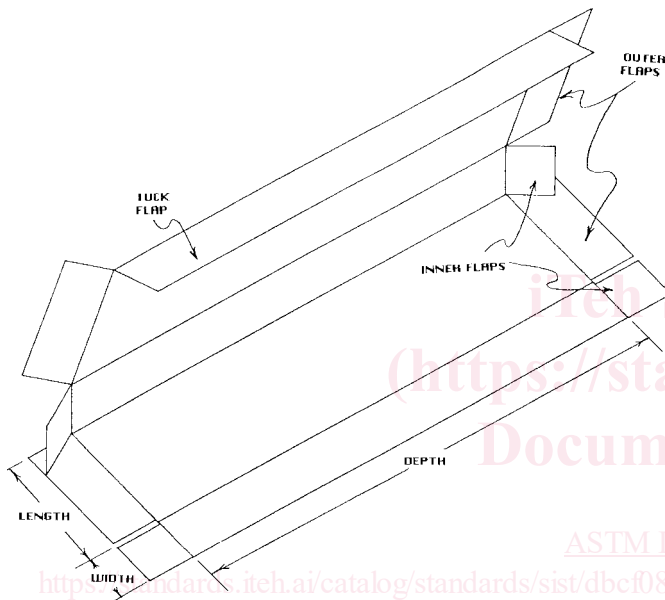

FIG. 12 Folder, Fiberboard; FPF—Five Panel Folder

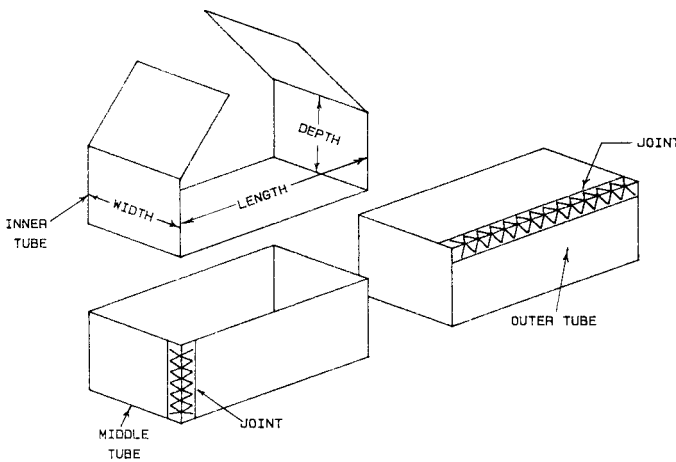

FIG. 13 Box, Fiberboard; TS—Triple Slide Box

two covers. The body consists of fiberboard, scored and secured to form a tube having parallel ends. Unless otherwise specified, the covers shall be Type I (see Fig. 16) stitch lock covers, 3 in. [76 mm] deep. When specified (see 8.1.10 and

TABLE 1 Size and Weight Limitations for Types CF^A and SF^A Class Domestic Fiberboard Boxes^B

| Type CF Variety | | Type SF | Max Weight of Boxes and Contents | | Max Inside Dimensions Length + Width + Depth | |
|-----------------|-----------------|---------|----------------------------------|--------|--|--------|
| SW ^A | DW ^A | Grade | lb | [kg] | in. | [mm] |
| 125 | ... | 125 | 20 | [9.1] | 40 | [1016] |
| 150 | ... | ... | 30 | [13.6] | 50 | [1270] |
| 175 | ... | 175 | 40 | [18.1] | 60 | [1524] |
| 200 | 200 | 200 | 65 | [29.5] | 75 | [1905] |
| 275 | 275 | 275 | 90 | [40.8] | 90 | [2286] |
| 350 | 350 | 350 | 120 | [54.4] | 100 | [2540] |
| | 500 | 500 | 140 | [63.5] | 110 | [2794] |
| | 600 | 600 | 160 | [72.6] | 120 | [3048] |

^AExplanation of abbreviations in Table 1:

CF—Corrugated Fiberboard

SF—Solid Fiberboard

SW—Singlewall Fiberboard

DW—Doublewall Fiberboard

^BSize and weight limitations may be modified or waived by the ordering activity, as necessary, when boxes are used for non-shipper or special purposes.

8.1.11), the cover shall be Type II (see Fig. 16), and the cover or covers of any type may be other than 3 in. [76 mm] in depth. Unless otherwise specified (see 8.1.12), the cover shall be unassembled.

6.2.1.10 *Interlocking Double Cover (IC/0325)*—This box shall meet the requirements of Fig. 8. The box consists of a body tube with top and bottom flanges and two interlocking covers. The box body shall be fiberboard (SW or DW) scored, slotted, and secured to form a tube having double scored short flanges (flaps) which form a lock with the flanges of the cover. The top and bottom covers shall be Type III (see Fig. 16) flange interlock covers and shall be secured by means of horizontal straps. Unless otherwise specified, (see 8.1.3) the flanges shall be 3 in. [76 mm] long for boxes made of variety SW fiberboard and 4 in. [102 mm] long for boxes made of variety DW fiberboard.

6.2.1.11 *Full Telescope (FTC/0301)*—This box shall meet the requirements of Fig. 9. The box consists of a body and a cover, each constructed of one piece of fiberboard, scored and slotted. The box dimensions shall be the inside measurements