



SLOVENSKI STANDARD
SIST ISO 11540:1995
01-junij-1995

NUý]fb]dc_fcj _]d]gU`]b`cnbU Yj Ub] \ `gfYXghYj ž_]`ŕ`i dcfUV`Uc`cHcW`Xc`%& " `YHJgHf cgh`!`J UfbcgfbY`nU hYj Y

Caps for writing and marking instruments intended for use by children up to 14 years of age -- Safety requirements

iTeh STANDARD PREVIEW

Capuchons d'instruments pour l'écriture et le marquage destinés à être utilisés par des enfants jusqu'à 14 ans inclus -- Exigences de sécurité

[SIST ISO 11540:1995](https://standards.itih.ai/catalog/standards/sist/b0d54a67-67dd-4aa9-ad30-552107910376/sist-iso-11540-1995)

Ta slovenski standard je istoveten z: ISO 11540:1993

ICS:

97.180	Razna oprema za dom in trgovino	Miscellaneous domestic and commercial equipment
97.190	Otroška oprema	Equipment for children

SIST ISO 11540:1995

en

iTeh STANDARD PREVIEW
(standards.iteh.ai)

SIST ISO 11540:1995

<https://standards.iteh.ai/catalog/standards/sist/b0d54a67-67dd-4aa9-ad30-552f079f0376/sist-iso-11540-1995>

INTERNATIONAL
STANDARD

ISO
11540

First edition
1993-09-01

**Caps for writing and marking instruments
intended for use by children up to 14 years
of age — Safety requirements**

iTeh STANDARD PREVIEW

(Standard iTeh.ai)
*Capuchons d'instruments pour l'écriture et le marquage destinés à être
utilisés par des enfants jusqu'à 14 ans inclus — Exigences de sécurité*

SIST ISO 11540:1995

<https://standards.iteh.ai/catalog/standards/sist/b0d54a67-67dd-4aa9-ad30-552f079f0376/sist-iso-11540-1995>



Reference number
ISO 11540:1993(E)

ISO 11540:1993(E)**Foreword**

ISO (the International Organization for Standardization) is a worldwide federation of national standards bodies (ISO member bodies). The work of preparing International Standards is normally carried out through ISO technical committees. Each member body interested in a subject for which a technical committee has been established has the right to be represented on that committee. International organizations, governmental and non-governmental, in liaison with ISO, also take part in the work. ISO collaborates closely with the International Electrotechnical Commission (IEC) on all matters of electrotechnical standardization.

Draft International Standards adopted by the technical committees are circulated to the member bodies for voting. Publication as an International Standard requires approval by at least 75 % of the member bodies casting a vote.

International Standard ISO 11540 was prepared by the British Standards Institution (as BS 7272:1990) and was adopted, under a special "fast-track procedure", by Technical Committee ISO/TC 10, *Technical drawings, product definition and related documentation*, in parallel with its approval by the ISO member bodies.

Annex A forms an integral part of this International Standard.

© ISO 1993

All rights reserved. No part of this publication may be reproduced or utilized in any form or by any means, electronic or mechanical, including photocopying and microfilm, without permission in writing from the publisher.

International Organization for Standardization
Case Postale 56 • CH-1211 Genève 20 • Switzerland

Printed in Switzerland

Caps for writing and marking instruments intended for use by children up to 14 years of age — Safety requirements

1 Scope

This International Standard specifies safety requirements for caps for writing and marking instruments which are designed or clearly intended for use by children up to 14 years of age. A test procedure for verifying the cap performance is given in annex A.

Caps for writing and marking instruments which are not designed or intended for use by children, e.g. jewellery pens, expensive fountain pens, professional technical pens, as well as transit caps for refills are not covered by this standard.

NOTE 1 Caps which do not comply with clause 3 should have the instrument or its packaging labelled with a warning as to the dangers of asphyxiation from pen caps.

2 Definitions

For the purposes of this International Standard, the following definitions apply.

2.1 writing and marking instruments: Any instrument with a detachable cap and a self-contained reservoir of ink or other marking fluid.

2.2 cap: Detachable closure designed to protect the applicator of the writing, marking or similar fluid.

3 Requirements

3.1 General

Caps shall comply with the performance requirements of 3.2, 3.3.1 or 3.3.2.

3.2 Cap size

When a cap is presented with its main axis perpendicular to a ring gauge of diameter $16^{+0,05}_0$ mm and

part of the cap enters that gauge, at least 5 mm of the length of the cap shall not pass freely through it (see figure 1).

Dimensions in millimetres

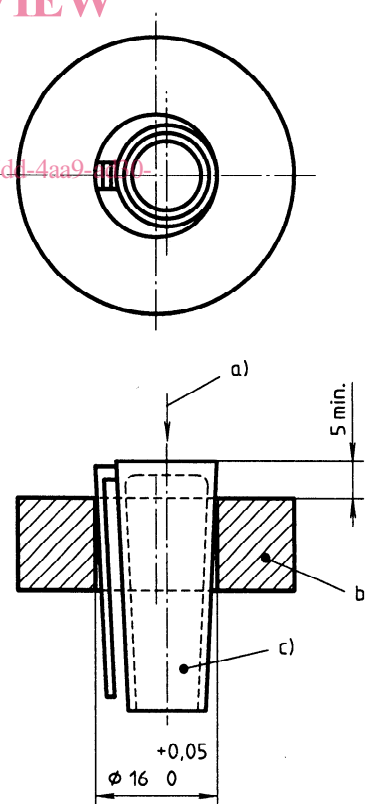

- a) Direction of fall
- b) Ring gauge
- c) Cap

Figure 1

ISO 11540:1993(E)

Caps which comply with this subclause are deemed to be too large to present an inhalation hazard.

3.3 Ventilated caps

3.3.1 Vent area

A continuous air passage of at least $6,8 \text{ mm}^2$ shall extend for the length of the cap body. The cross-sectional area of the continuous air passage, if not entirely enclosed, shall be that area that would be encompassed by a thin piece of cotton thread wrapped tautly around any section perpendicular to the main axis or to the largest dimension (see figure 2).

Where a clip or other protrusion is the means of providing the air passage, it shall be securely fixed and shall not be more than 2 mm short of either end of the cap body. However, the clip may extend any distance beyond the end of the cap body.

Caps complying with this requirement are deemed not to present an asphyxiation hazard.

3.3.2 Air flow

Caps shall permit a minimum air flow of 8 l/min measured at room temperature, with a maximum pressure difference of $1,33 \text{ kPa}$ when tested in accordance with annex A.

NOTE 2 A single circular orifice with a cross-sectional area of approximately $3,4 \text{ mm}^2$ can be expected to satisfy this criterion, but multiple smaller orifices may require a larger total cross-sectional area.

Caps complying with this requirement are deemed not to present an asphyxiation hazard.

4 Marking

Writing or marking instruments should be legibly and indelibly marked on the instrument or its packaging with the following:

- the name, trademark or other means of identifying the manufacturer/supplier;
- reference to this International Standard, i.e. ISO 11540.

iTeh STANDARD PREVIEW
(standards.iteh.ai)

Dimensions in millimetres

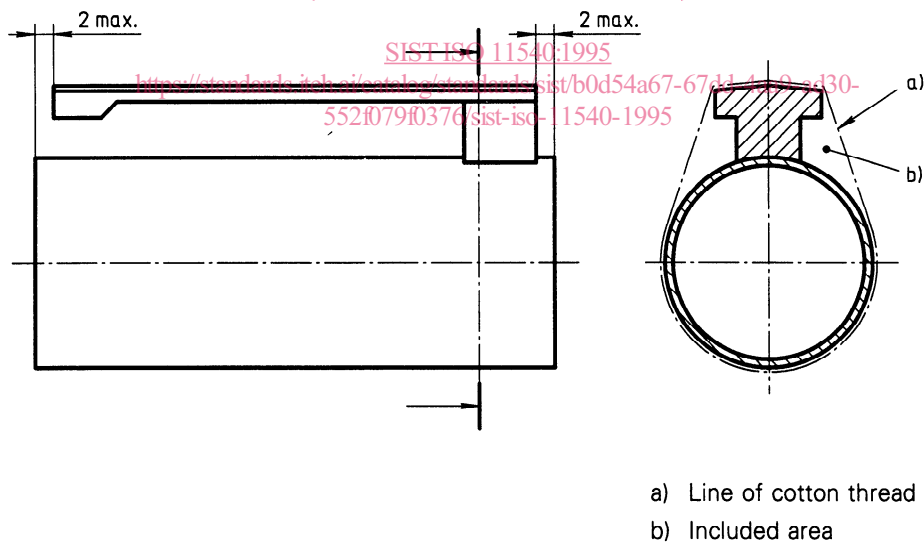

Figure 2

Annex A (normative)

Test for air flow

A.1 Principle

The test cap is fully inserted into an elastomeric tube of the appropriate diameter and the air flow through the tube and the pressure difference are measured in both directions.

A.2 Apparatus (see figure A.1)

A.2.1 Air supply, pulse-free, at a rate of at least 25 l/min and within the pressure range 4 kPa to 50 kPa.

A.2.2 Flow regulator, capable of controlling the air flow with an accuracy of $\pm 0,1$ l/min.

A.2.3 Flow gauge, capable of measuring flow between 5 l/min and 25 l/min with an accuracy of $\pm 0,2$ l/min.

A.2.4 Pressure gauge, capable of measuring pressure of at least 4 kPa to an accuracy of $\pm 0,01$ kPa.

A.2.5 Coupling and tubing, suitable for connecting the equipment described above in accordance with figure A.1.

A.2.6 Elastomeric tubing, with an internal diameter of 80 % to 85 % of the circumscribing circle of the cap to be tested, measured at its widest point. The wall thickness of the tubing shall be $0,75 \text{ mm} \pm 0,25 \text{ mm}$ and the Shore A hardness shall be 55 ± 10 .

A.3 Procedure

A.3.1 Cut the elastomeric tubing (A.2.6) into a length such that when the cap is inserted there is a relaxed diameter of tubing at both ends of the cap when connected to the apparatus.

A.3.2 Apply a soap solution or other suitable low viscosity lubricant to the full internal area of the tubing.

A.3.3 Insert the cap into approximately the centre of the tube length and ensure that as far as practicable the cap is parallel to the major axis of the tubing.

A.3.4 Using suitable connectors and tubing (A.2.5), connect the tube/cap assembly (A.3.3) to the apparatus as in figure A.1.

A.3.5 Turn on the air supply (A.2.1) and adjust the flow until the pressure gauge (A.2.4) indicates a pressure difference of 1,33 kPa.

A.3.6 Record the flow-rate indicated on the flow gauge (A.2.3) at this pressure.

A.3.7 Turn off the air supply, remove and reverse the tube/cap assembly and repeat A.3.4 to A.3.6.

A.3.8 Test 10 caps, giving a total of 20 air flow results. Record separately the air flows for each cap tested and report the minimum air flow recorded.

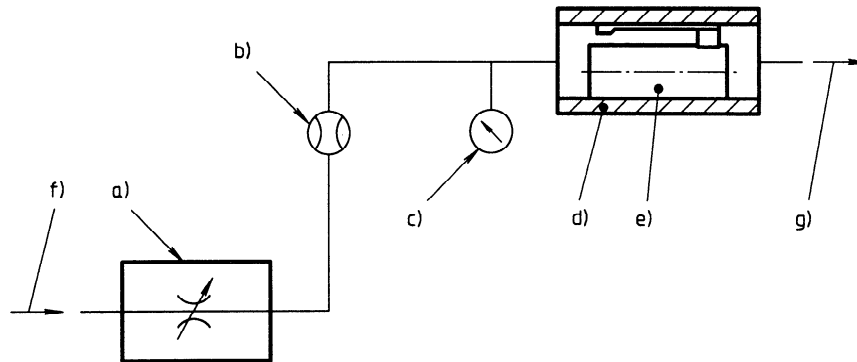

- a) Flow control valve
- b) Flowmeter
- c) Pressure gauge
- d) Tubing
- e) Cap
- f) Air supply
- g) Air exhaust

Figure A.1
iTeh STANDARD PREVIEW
(standards.iteh.ai)

SIST ISO 11540:1995

<https://standards.iteh.ai/catalog/standards/sist/b0d54a67-67dd-4aa9-ad30-552f079f0376/sist-iso-11540-1995>