**Stationary source emissions —
Determination of the mass concentration of
nitrogen oxides —
Naphthylethylenediamine photometric
method**

iTeh STANDARD PREVIEW
*Émissions de sources fixes — Détermination de la concentration en masse
des oxydes d'azote — Méthode photométrique à la naphthyléthylène diamine
(NEDA)*
(standards.iteh.ai)

ISO 11564:1998

<https://standards.iteh.ai/catalog/standards/sist/6428a29d-6e66-4721-a17b-d298a00f3942/iso-11564-1998>



| Contents | Page |
|-------------------------------------|------|
| 1 Scope..... | 1 |
| 2 Principle | 1 |
| 3 Reagents | 2 |
| 4 Apparatus..... | 2 |
| 5 Sampling techniques | 5 |
| 6 Determination | 10 |
| 7 Calculation | 11 |
| 8 Interferences | 12 |
| 9 Performance characteristics | 12 |
| 10 Test report..... | 13 |
| Annex A: Experimental results | 14 |
| Annex B: Bibliography..... | 16 |

iTeh STANDARD PREVIEW
(standards.iteh.ai)
<https://standards.iteh.ai/catalog/standards/sist/6428a29d-6e66-4721-a17b-d298a00f3942/iso-11564-1998>

© ISO 1998

All rights reserved. Unless otherwise specified, no part of this publication may be reproduced or utilized in any form or by any means, electronic or mechanical, including photocopying and microfilm, without permission in writing from the publisher.

International Organization for Standardization
Case postale 56 • CH-1211 Genève 20 • Switzerland
Internet central@iso.ch
X.400 c=ch; a=400net; p=iso; o=isocs; s=central

Printed in Switzerland

Foreword

ISO (the International Organization for Standardization) is a worldwide federation of national standards bodies (ISO member bodies). The work of preparing International Standards is normally carried out through ISO technical committees. Each member body interested in a subject for which a technical committee has been established has the right to be represented on that committee. International organizations, governmental and non-governmental, in liaison with ISO, also take part in the work. ISO collaborates closely with the International Electrotechnical Commission (IEC) on all matters of electrotechnical standardization.

Draft International Standards adopted by the technical committees are circulated to the member bodies for voting. Publication as an International Standard requires approval by at least 75 % of the member bodies casting a vote.

iTeh STANDARD PREVIEW

International Standard ISO 11564 was prepared by Technical Committee ISO/TC 146, *Air quality*, Subcommittee SC 1, *Stationary source emissions*.

Annexes A and B of this International Standard are for information only.

<https://standards.iteh.ai/catalog/standards/sist/6428a29d-6e66-4721-a17b-d298a00f3942/iso-11564-1998>

iTeh STANDARD PREVIEW
(standards.iteh.ai)

ISO 11564:1998

<https://standards.iteh.ai/catalog/standards/sist/6428a29d-6e66-4721-a17b-d298a00f3942/iso-11564-1998>

Stationary source emissions — Determination of the mass concentration of nitrogen oxides — Naphthylethylenediamine photometric method

1 Scope

This International Standard specifies a photometric method for the determination of the mass concentration of nitrogen oxides in exhaust gases from ducts or chimneys.

NOTE — Nitrogen oxides (NO_x) are practically defined as the sum of NO and NO_2 . The mass concentration of NO_x is expressed as the equivalent NO_2 concentration in milligrams per cubic metre.

The method is applicable to the determination of the mass concentration of nitrogen oxides in exhaust gases from combustion processes, processes for surface treatment of metals and from organic chemical reactions, if necessary after removal by washing, in-furnace reduction and/or catalytic denitration, prior to their dispersion into the atmosphere.

This International Standard is applicable to the concentration range 5 mg/m^3 to 1000 mg/m^3 as NO_2 for a sample gas volume of 1000 ml.

For gas concentrations greater than 1000 mg/m^3 , the determination of sample gas concentrations up to 5000 mg/m^3 can be performed by diluting the sample solution or by taking an aliquot of the sample solution.

This International Standard is not applicable to the determination of dinitrogen monoxide (N_2O).

2 Principle

Nitrogen oxides in a gas sample are absorbed in an alkaline hydrogen peroxide solution ($1,2 \text{ mol/l NaOH/0,6 \% H}_2\text{O}_2$) in the presence of cupric ions (Cu^{2+}), which catalyse the oxidation reaction into nitrite ions.

At the above concentrations, nitrate ions are not produced in the absorption solution.

Hydrogen peroxide in the absorption solution interferes with the colour development. Therefore, hydrogen peroxide is catalytically decomposed with cupric ions by heating the solution for 30 min in a hot water bath at $80 \text{ }^\circ\text{C}$.

Nitrite concentration is determined by measuring the absorbance of the coloured solution produced by the reaction with sulfanilamide and naphthylethylenediamine (NEDA) at a wavelength of 545 nm using a photometer.

The mass concentration of nitrogen dioxide is obtained by comparison of the absorbance obtained with a calibration graph prepared using a pure sodium nitrite standard solution.

The sampling time lies between 5 min and 12 min. The time required for the determination is about 60 min.

3 Reagents

Use only reagents of recognized analytical grade and distilled water free of nitrite during the analysis.

3.1 Absorption solution (1,2 mol/l NaOH, 0,6 % H₂O₂, 4,0 % Na₂CO₃, 0,0005 % HCOONa)

Dissolve 48 g of sodium hydroxide, 40,0 g of sodium carbonate and 5 mg sodium formate in about 800 ml of water, add 20 ml of hydrogen peroxide (30 %), and make up to 1000 ml with water.

NOTE — The absorption solution can be stored in a stoppered vessel in a cool dark place for a week. Shaking promotes the decomposition of hydrogen peroxide.

3.2 Cupric sulfate solution (4×10^{-4} mol/l)

Dissolve 1,0 g of cupric sulfate (CuSO₄ · 5H₂O) in water in a 1000 ml volumetric flask and make up to the mark. Then dilute 10 ml of this solution in a 100 ml volumetric flask with water and make up to the mark.

3.3 Sulfanilamide/ hydrochloric acid solution (sulfanilamide 0,5 %, hydrochloric acid 20 %)

Dissolve 1,0 g of sulfanilamide in about 50 ml water and add 112 ml of hydrochloric acid (37 %) in a 200 ml volumetric flask. Make up to the mark with water.

3.4 Naphthylethylenediamine (NEDA) solution (0,1 %)

Dissolve 0,1 g of NEDA dichloride in 100 ml water.

3.5 Nitrite solution (250 mg/l, expressed as NO₂⁻)

ISO 11564:1998
<https://standards.iteh.ai/catalog/standards/sist/6428a29d-6e66-4721-a17b->

Dissolve 375 mg of dried sodium nitrite (NaNO₂) and 0,2 g of sodium hydroxide (NaOH) in water in a 1000 ml volumetric flask. Make up to the mark with water and mix well.

NOTE — The solution is stable for at least three months if stored in a well-stoppered bottle.

3.6 Dilute nitrite solution (20 mg/l, expressed as NO₂⁻)

Transfer 40,0 ml of the nitrite solution (3.5) to a 500 ml volumetric flask. Make up to the mark with water and mix well; 1 ml of this solution contains 20 µg of NO₂⁻.

Prepare this solution immediately before use.

4 Apparatus

4.1 Sampling probe, made of corrosion-resistant material, e.g. borosilicate or quartz glass, internal diameter 6 mm to 10 mm; heated if necessary to a temperature above the dewpoint.

4.2 Particle filter, to remove particulate material from the gas, made e.g. from borosilicate or quartz glass. The filter may be integrated in the sampling probe or separate and may be located inside or outside the waste gas duct. An example of an outside filter is shown in figure 1. A suitable inert filter material is quartz wool; heated if necessary.

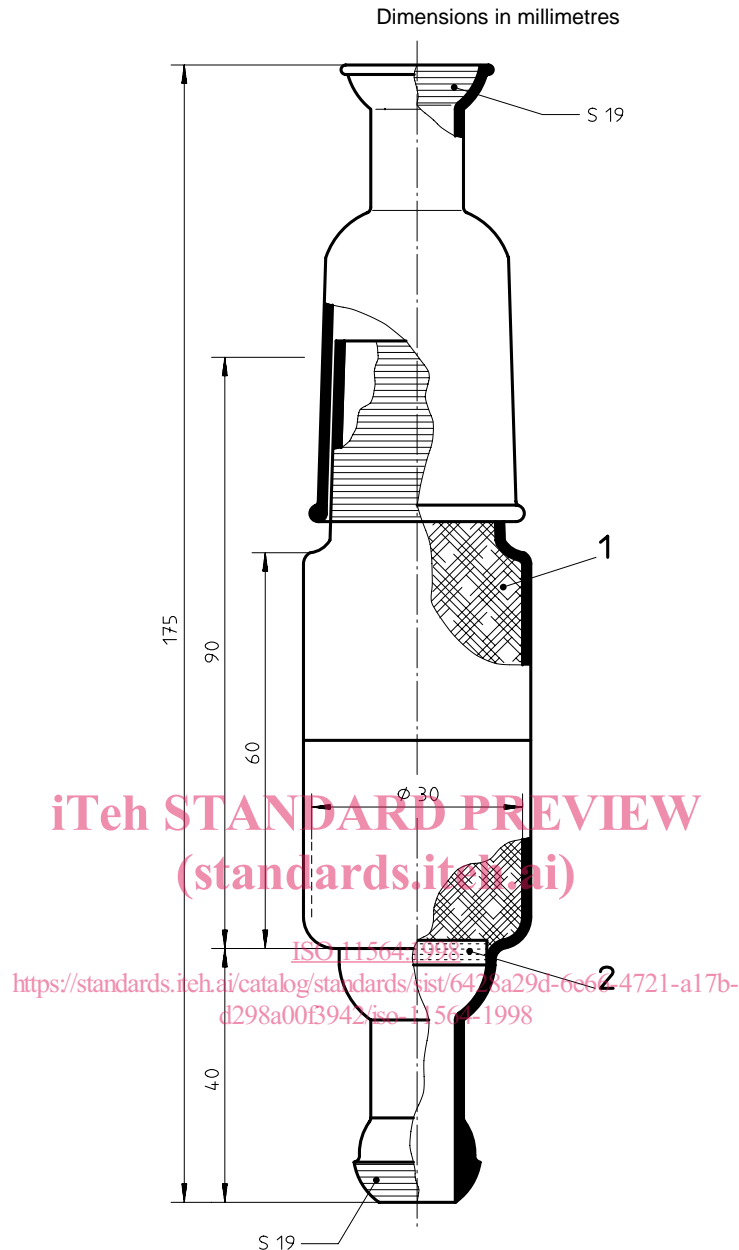

Key

- 1 Quartz wool, about 0,5 g to 0,8 g, packed progressively
- 2 Perforated plate or sintered filter

Figure 1 — Example of a particle filter used outside the waste gas duct

4.3 Heating element, e.g. thyristor-controlled heating tapes (for heating of sampling device outside the stack).

4.4 T-piece, e.g. borosilicate or quartz glass, heated if necessary.

4.5 Gas sampling flask, 1000 ml flask, having one or two taps [see figure 2 a) and b)]. The capacity of the flask shall be calibrated by the volumetric method using water.

NOTE — Instead of a gas sampling flask of exactly known volume, a syringe (volume 200 ml or 500 ml, see 4.13) may be used. In this case the given performance characteristics may not be reached.

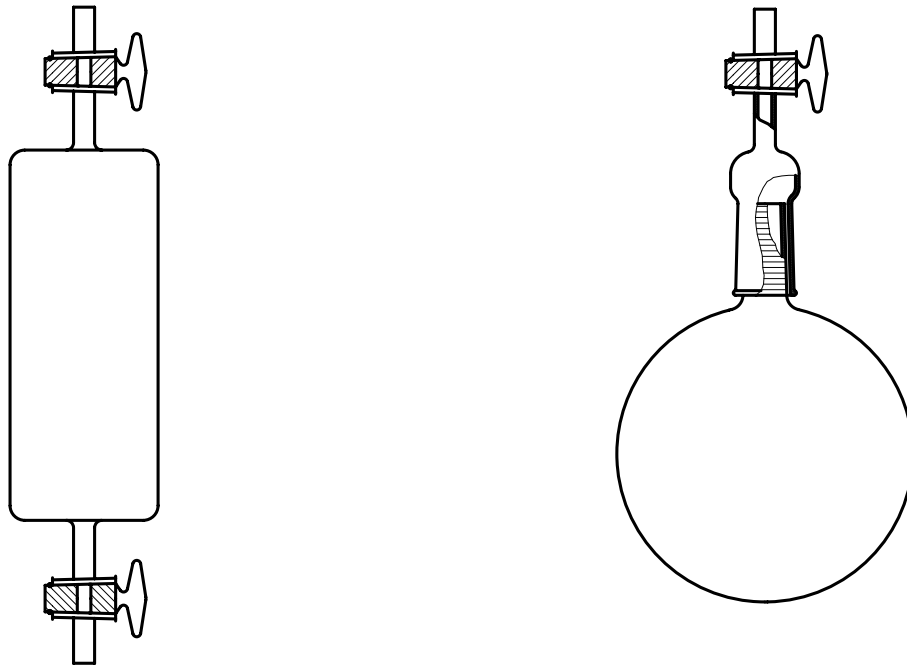

a) with two one-way taps

b) with one one-way tap

Figure 2 — Examples of gas sampling flasks (approximately 1000 ml capacity)

iTeh STANDARD PREVIEW

4.6 Washing bottles, to remove acid gases (e.g. SO₂, HCl) to protect the suction pump. These are only necessary if a high amount of acid gases are present in the sample gas and the suction pump is not corrosion-resistant.

4.7 Drying tube, to protect the pump. Use granular silica gel or calcium chloride for the desiccant.

4.8 Vacuum pump, to evacuate the flask to a pressure below 20 hPa.

4.9 Pressure meter, to measure the pressure before and after gas sampling; a mercury or equivalent pressure meter; suitable to measure pressure in the range 1 hPa to 1000 hPa.

4.10 Critical nozzle, comprising a glass capillary with external diameter 6 mm, internal diameter 1 mm and length approximately 60 mm. In addition, the capillary shall be sharply narrowed at one end by melting.

Its throughput characteristics should be such that, in a gas sampling flask of approx. 1 l capacity, a linear rise in pressure from 10 hPa to about 500 hPa to 600 hPa occurs in a period of 5 min to 12 min.

For the test, one tap of an evacuated gas sampling flask is connected to the pressure meter, the other to the capillary. Following opening of the taps, the pressure rise is noted.

4.11 Thermometer, to measure the ambient temperature when sampling gas.

4.12 Photoelectric spectrophotometer or photoelectric photometer, capable of measuring at a wavelength of 545 nm and of accepting cells with an optical pathlength of 1,0 cm to 5,0 cm.

NOTE — In order to protect finger skin from alkaline solution, the use of thin rubber gloves is recommended. Polyvinylchloride gloves are not recommended because they are apt to slip on a glass surface.

4.13 100 ml syringe (optional), as shown in figure 3. The syringe can be used to introduce the absorption solution into the sampling flask.

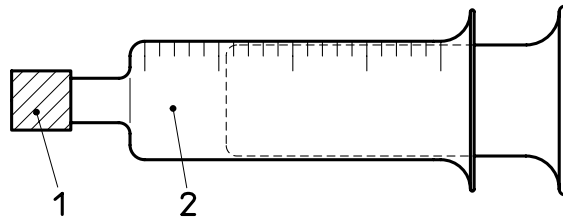

Key

- 1 Silicone rubber tube
- 2 Absorption solution

Figure 3 — Syringe for introducing the absorption solution

5 Sampling techniques

5.1 General

Depending on the measuring task and the available equipment, a sampling train in accordance with one of the examples in figure 4 shall be installed.

The sampling train shown in figure 4 b) can only be used if it is known that the amount of NO_2 is negligible. Generally in stack gases from incinerators, the amount of NO_2 compared with the amount of total nitrogen oxides (sum of $\text{NO} + \text{NO}_2 = \text{NO}_x$) is low; if the amount of NO_2 is lower than 10% NO_x the loss of NO_2 in the condensate in general is negligible.

Ensure that there are no leaks in the sampling train.
<https://standards.iteh.ai/catalog/standards/sist/6428a29d-6e66-4721-a17b-d298a00f3942/iso-11564-1998>

5.2 Gas sampling with flask with two taps

5.2.1 Sampling with evacuated flask

5.2.1.1 Connection of flask and measurement of pressure and temperature before gas sampling

Connect the dried and evacuated sampling flask (6) to the sampling apparatus as shown in figure 4 a). Start the suction pump (10) and purge the sampling line for several minutes (minimum 3 min) with the flue gas. Then open the tap of the sampling flask (b) attached to the pressure meter and measure and record the pressure in the flask (p_0). Simultaneously measure and record the temperature (t_0) near the flask, which should be identical to the temperature in the flask.

5.2.1.2 Introduction of sample gas and measurement of pressure and temperature after gas sampling

Open the tap of the sampling flask (a) attached to the capillary. The gas sampling flask shall be filled with sample gas only up to a pressure of 100 hPa to 600 hPa (depending on the concentration of NO_x).

After closing the tap (a) from the flue, allow the sample to cool to ambient temperature, typically for 3 min but not longer than 5 min. After that time, the pressure indicated at the pressure meter should be stable. Measure and record the pressure in the flask (p_1). Verify the temperature near the flask again (t_1); normally $t_1 = t_0$.

NOTE — Recommendations for choosing sampling pressure as a function of concentration of NO_2 and of the optical length of the cell are given in table 1.

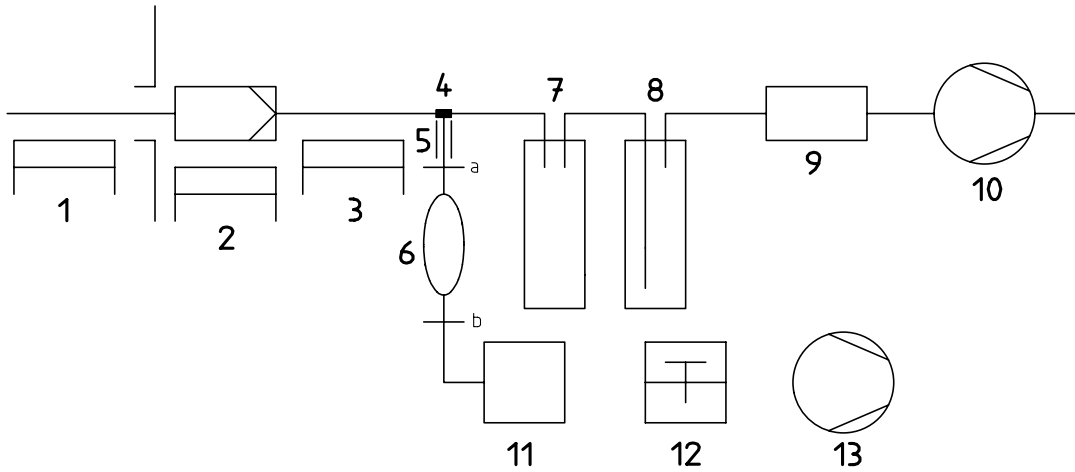

Key

- 1 Sampling probe, heated when appropriate
- 2 Particle filter, heated when appropriate
- 3 Sampling line (as short as possible), heated when appropriate
- 4 T-piece
- 5 Capillary
- 6 Gas sampling flask [according to figure 2 a)]
- 7 Vacant bottle (to prevent back-flow), when appropriate
- 8 Washing bottle, containing sodium hydroxide solution, when appropriate
- 9 Drying tube
- 10 Suction pump
- 11 Pressure meter
- 12 Thermometer
- 13 Vacuum pump

iTeh STANDARD PREVIEW
(standards.iteh.ai)

a) Heated sampling system, sampling flask with two taps
<https://standards.iteh.ai/catalog/standards/sist/6428a29d-6e66-4721-a17b-d298a00f3942/iso-11564-1998>

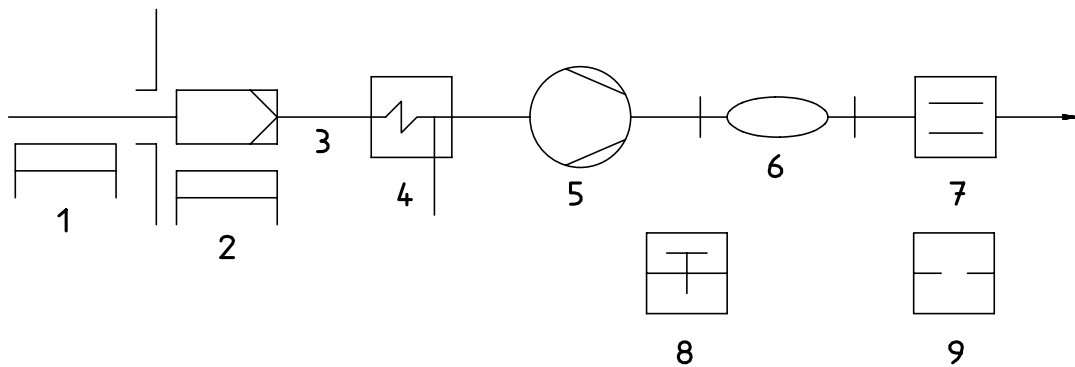

Key

- 1 Sampling probe, heated when appropriate
- 2 Particle filter, heated when appropriate
- 3 Sampling line (as short as possible), heated when appropriate
- 4 Condensate separator
- 5 Suction pump
- 6 Gas sampling flask
- 7 Gas flow meter
- 8 Thermometer
- 9 Barometer

b) Condensing sampling system, sampling flask with two taps

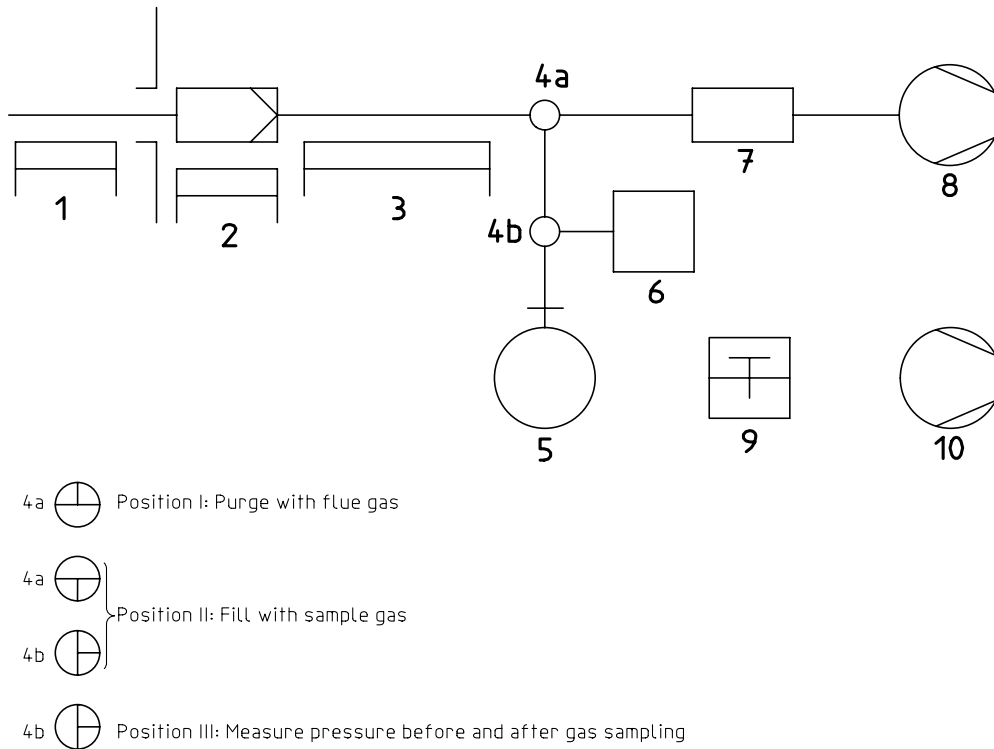
**Key**

- 1 Sampling probe, heated when appropriate
- 2 Particle filter, heated when appropriate
- 3 Sampling line (as short as possible), heated when appropriate
- 4 Three-way valve
- 5 Gas sampling flask [according to figure 2 b)]
- 6 Pressure meter
- 7 Drying tube
- 8 Suction pump
- 9 Thermometer
- 10 Vacuum pump

iTech STANDARD PREVIEW
(standards.iteh.ai)

ISO 11564:1998
<https://standards.iteh.ai/catalog/standards/sist/6428a29d-6e66-4721-a17b-d298a00f3942/iso-11564-1998>

c) Heated sampling system, sampling flask with one tap**Figure 4 — Examples of a sampling train****Table 1**

| Concentration of NO _x mg/m ³ (expressed as NO ₂) | Length of optical cell cm | Pressure after sampling kPa |
|---|------------------------------|--------------------------------|
| 100 | 5 | 40-60 |
| 200 | 5 | 20-40 |
| 500 | 1 | 40-60 |
| 500 | 5 | 10-20 |
| 1000 | 1 | 20-40 |
| 2000 | 1 | 10-20 |

5.2.1.3 Detaching the flask

Close the tap (b) of the gas sampling flask. Detach the flask (6) from the gas sampling apparatus.

NOTE — The absorption solution should be introduced after taking the gas sample in the sampling flask, because the pressure of the gas will drop due to absorption of carbon dioxide from the sample gas.