

---

---

**Determination of gas porosity and gas permeability of hydraulic binders containing embedded radioactive waste**

*Détermination de la porosité et de la perméabilité au gaz de liants hydrauliques contenant des déchets radioactifs*

<https://standards.iteh.ai>  
Document Preview

[ISO 11599:1997](https://standards.iteh.ai/catalog/standards/iso/4189ca46-6a3a-4f44-b88d-cedb66b86976/iso-11599-1997)

<https://standards.iteh.ai/catalog/standards/iso/4189ca46-6a3a-4f44-b88d-cedb66b86976/iso-11599-1997>



## Contents

	Page
1 Scope.....	1
2 Sample preparation .....	1
3 Measurement of open gas porosity .....	5
4 Measurement of gas permeability.....	8

## Annexes

A Gas pycnometer .....	12
B Bibliography .....	16

iTech Standards  
(<https://standards.itih.ai>)  
Document Preview

[ISO 11599:1997](https://standards.itih.ai/catalog/standards/iso/4189ca46-6a3a-4f44-b88d-cedb66b86976/iso-11599-1997)

<https://standards.itih.ai/catalog/standards/iso/4189ca46-6a3a-4f44-b88d-cedb66b86976/iso-11599-1997>

© ISO 1997

All rights reserved. Unless otherwise specified, no part of this publication may be reproduced or utilized in any form or by any means, electronic or mechanical, including photocopying and microfilm, without permission in writing from the publisher.

International Organization for Standardization  
Case postale 56 • CH-1211 Genève 20 • Switzerland  
Internet central@iso.ch  
X.400 c=ch; a=400net; p=iso; o=isocs; s=central

Printed in Switzerland

## Foreword

ISO (the International Organization for Standardization) is a worldwide federation of national standards bodies (ISO member bodies). The work of preparing International Standards is normally carried out through ISO technical committees. Each member body interested in a subject for which a technical committee has been established has the right to be represented on that committee. International organizations, governmental and non-governmental, in liaison with ISO, also take part in the work. ISO collaborates closely with the International Electrotechnical Commission (IEC) on all matters of electrotechnical standardization.

Draft International Standards adopted by the technical committees are circulated to the member bodies for voting. Publication as an International Standard requires approval by at least 75 % of the member bodies casting a vote.

International Standard ISO 11599 was prepared by Technical Committee ISO/TC 85, *Nuclear energy*, Subcommittee SC 5, *Nuclear fuel technology*.

Annex A forms an integral part of this International Standard. Annex B is for information only.

[ISO 11599:1997](https://standards.iteh.ai/catalog/standards/iso/4189ca46-6a3a-4f44-b88d-cedb66b86976/iso-11599-1997)

<https://standards.iteh.ai/catalog/standards/iso/4189ca46-6a3a-4f44-b88d-cedb66b86976/iso-11599-1997>

## Introduction

Hydraulic binder-based matrices can be hardened pure cement, mortar or concrete containing embedded wastes; these wastes can be radioactive or non-radioactive.

It has been observed that the durability of these matrices, as well as the leaching rate of immobilized radionuclides in water are very largely dependent on gas open porosity and gas permeability of the matrix. Also, permeability and open porosity can be related to the homogeneity of a hydraulic binder matrix.

The objective of this International Standard is to offer a methodology that allows rapid estimation of the gas porosity and permeability of hydraulic binders. A direct comparison of the results obtained in different laboratories would thus be possible by checking the quality or ageing behaviour of a waste form. The International Standard, once implemented, would reduce discrepancies between laboratories.

(<https://standards.iteh.ai>)  
Document Preview

[ISO 11599:1997](https://standards.iteh.ai)

<https://standards.iteh.ai/catalog/standards/iso/4189ca46-6a3a-4f44-b88d-cedb66b86976/iso-11599-1997>

# Determination of gas porosity and gas permeability of hydraulic binders containing embedded radioactive waste

## 1 Scope

This International Standard describes the principles and methodologies of measuring both gas open porosity and permeability of hydraulic binder-based matrices used for immobilization of radioactive waste. The measurements can be carried out by using different apparatus designed and constructed on the basis of a few recommended characteristics. The measurements can be performed on samples prepared in a laboratory or taken from industrial production. Samples can be obtained by moulding or by coring a block.

## 2 Sample preparation

The samples may be obtained either by moulding or by coring of a block. The choice shall be made according to the purpose of the study.

### 2.1 Moulded samples

The samples are moulded when the hardened cement, mortar or concrete has been prepared either in the laboratory or taken from an industrial or pilot plant.

#### 2.1.1 Sample size

The sample shall be an orthogonal cylinder with square cross-section, or a rectangular parallelepiped. The acceptable sample length is in the range between  $(40 \pm 2)$  mm and  $(220 \pm 5)$  mm. The recommended length is  $(110 \pm 3)$  mm.

The end orthogonalities in relation to the generating line direction shall be  $(90 \pm 1)^\circ$ . Straight section inherent flatness shall be 0,5 mm.

#### 2.1.2 Mould

The sample is poured into moulds made of steel, plastic or cardboard with an inner sulfurized paper lining.

Mould design shall allow withdrawal of the pattern from the mould without knocking flakes off the solid angle of intersection of the two surfaces. During mould filling, the mixture is stirred with a straight rod to eliminate possible air bubbles. If drum vibration is arranged for an industrial process, the sample is compressed with a vibrating microtable.

Levelling of the upper surface of the sample is carried out with a steel strip. The cross-section of the strip shall be trapezoidal with a  $45^\circ$  angle. The dimensions of the strip shall be as follows:

- length: 450 mm;
- width of the major base: 60 mm;
- thickness: 15 mm.

In a first step, levelling enables a raw surface of a sample to be obtained using the strip's chamfered edge (see operation A in figure 1). In a second step, use the strip's shorter base to obtain the final surface of the sample to be used (see operation B in figure 1).

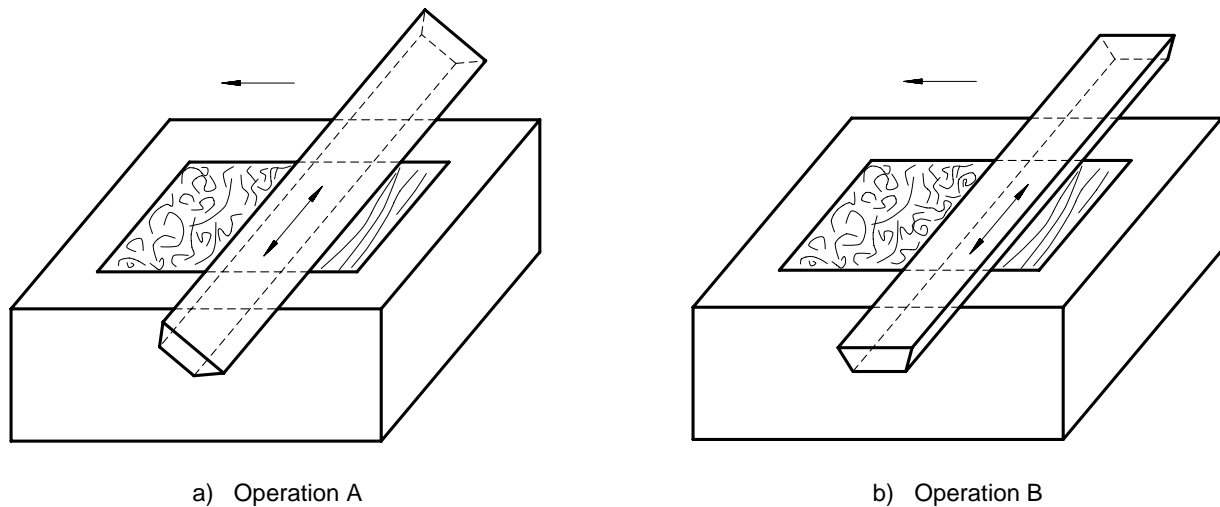

Figure 1 — Levelling of moulded sample

Raw and final levellings are made with a sawing movement (an alternating movement). For each levelling, two passes are made with a change in direction of 90°. During levelling, cavities are filled with the same mixture.

All details of this operation shall be noted in the test report.

## 2.2 Core samples

### 2.2.1 General

Core drilling is carried out with a tool adapted to the desired final diameter of the sample. During coring, overheating of the tool can be damaging for the material; air or gas cooling shall then be performed. A gas or air cooling filtration system shall be installed to avoid excessive radioactive contamination for tests with actual embedded radioactive or hazardous waste.

The coring material, a cylindrical and tubular muff, is fitted with a diamond abrasive ring. The tool's rotational speed is defined for each manufacturer's specifications. In the absence of specification, a rotational speed of 600 min<sup>-1</sup> to 800 min<sup>-1</sup> is recommended. In general, the core is cut into sections with a carborundum plate to obtain samples of a length suitable for tests.

When a matrix with embedded waste is cored, the sample shall be chosen to differentiate homogeneous and heterogeneous parts.

### 2.2.2 Samples from homogeneous waste forms

Figure 2 shows the procedure used. The cores are obtained in a direction parallel to the container axis, halfway between the centre and the lateral surface of the waste package. The core is then cut as shown in the diagram to obtain five samples.

### 2.2.3 Samples from heterogeneous waste forms

Figure 3 shows the procedures used for samples from cylindrical or parallelepipedic blocks having a volume  $\leq 2 \text{ m}^3$ . One long vertical core and three cross-cores can be obtained to produce five samples.

Figure 4 shows the procedures used for samples from cylindrical or parallelepipedic blocks having a volume  $> 2 \text{ m}^3$ . Two vertical cores and three cross-cores can be obtained. In this case, the number of samples is seven.

If the integrity of the package is not guaranteed during these two procedures, it is possible to sample only on the top of the container. In this case, the statistic sampling representative will not be as accurate as in the procedure recommended above.

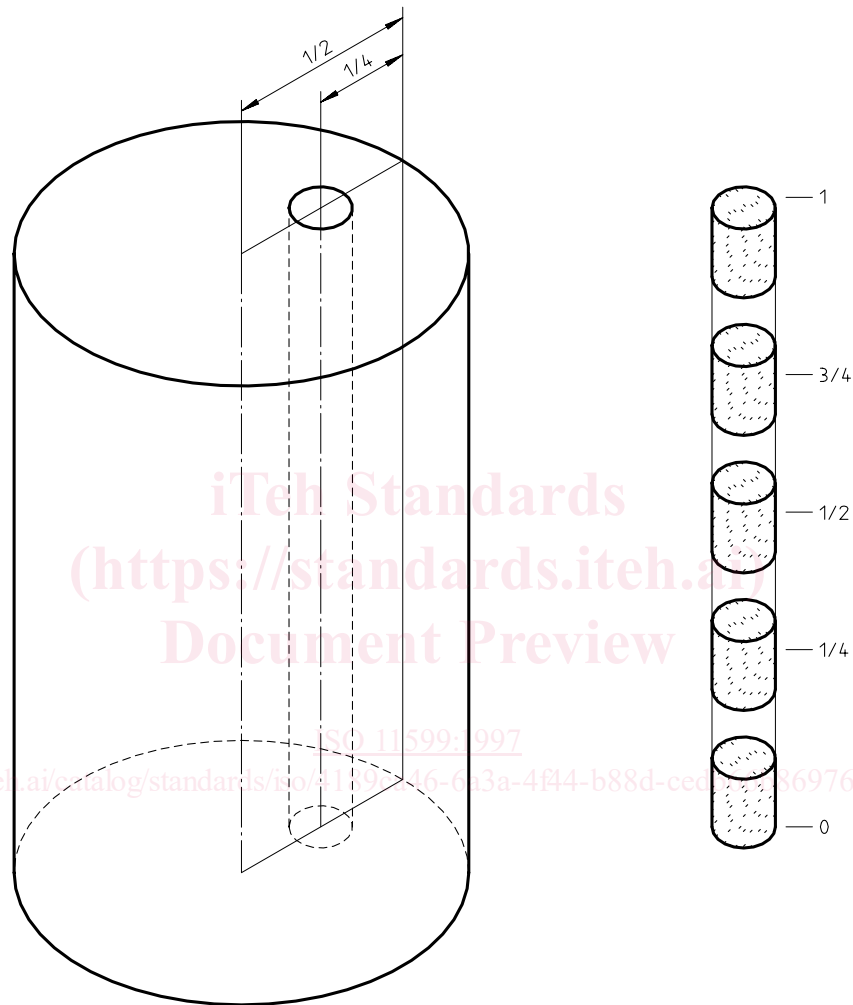

Figure 2 — Sampling of homogeneous waste forms

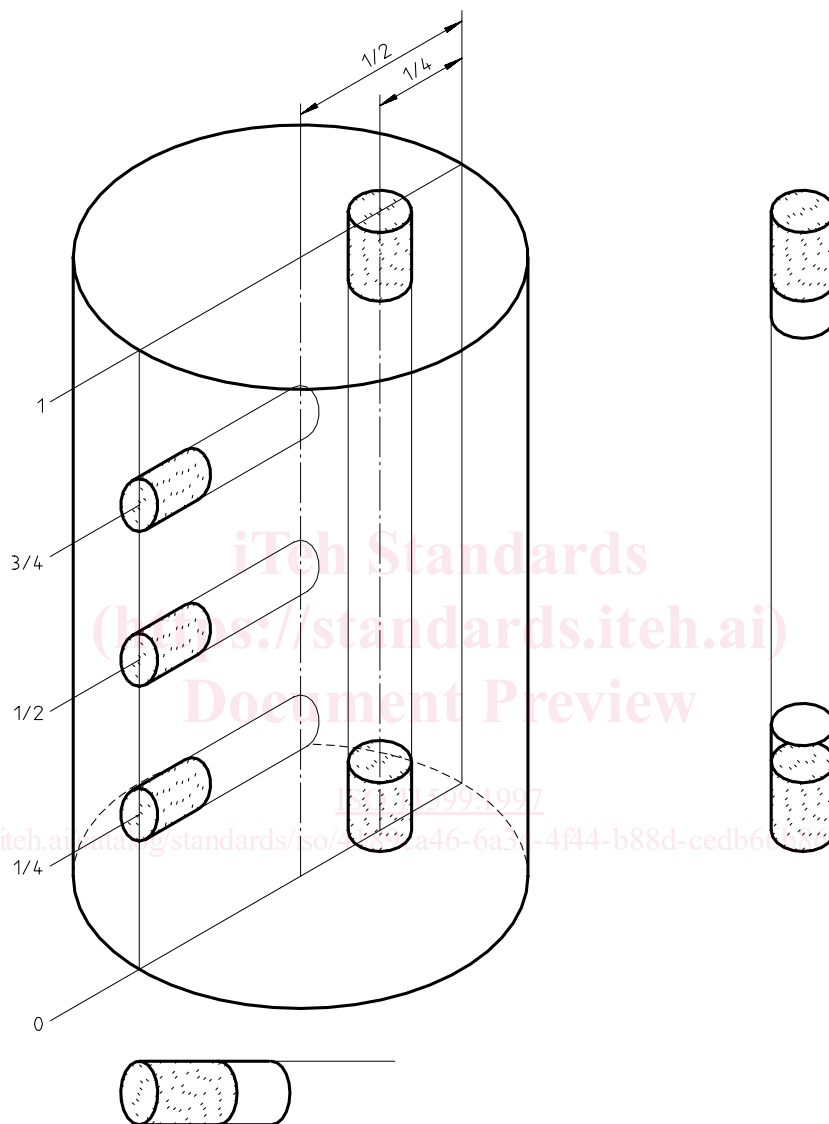

Figure 3 — Sampling of heterogeneous waste forms of block volume  $\leq 2 \text{ m}^3$



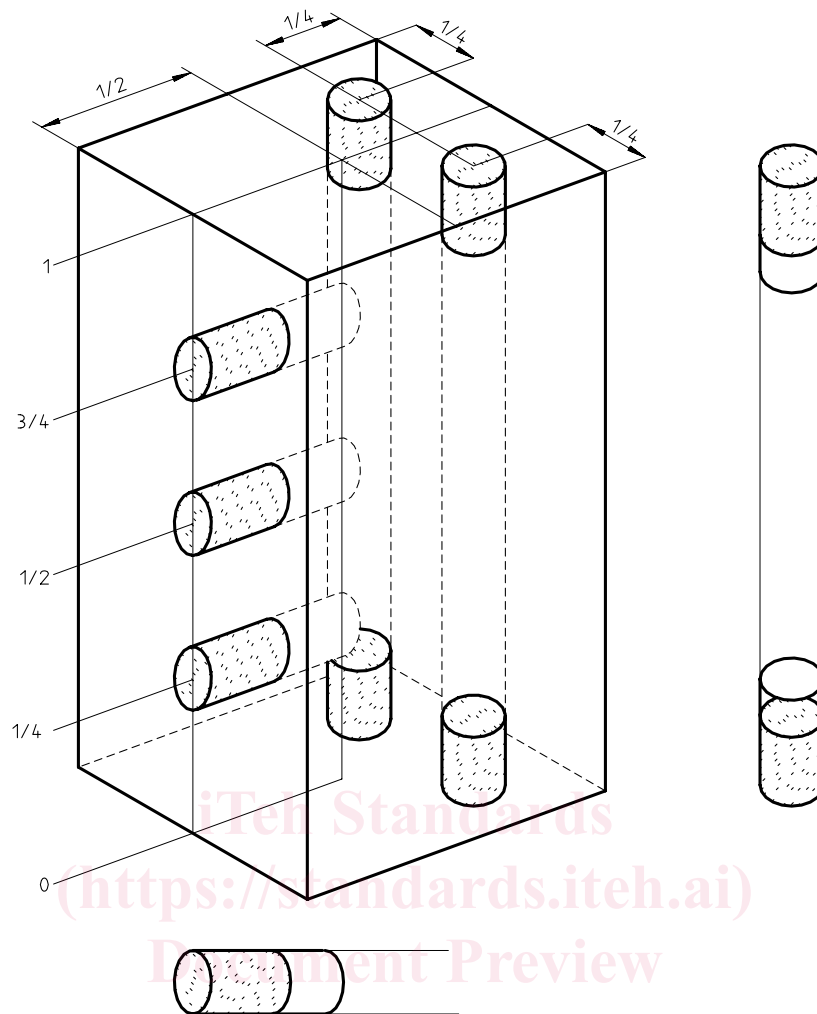

Figure 4 — Sampling of heterogeneous waste forms of block volume > 2 m<sup>3</sup>

### 3 Measurement of open gas porosity

#### 3.1 Definition

The sample open gas porosity ( $P$ ), expressed as a percentage, is the ratio of the open pore volume ( $V_o$ ) of a sample to the geometrical volume ( $V_g$ ) (also called the apparent volume). The open pore volume of a sample is also equal to the geometrical volume minus the real volume ( $V_s$ ) of the sample.

$$P = \frac{V_o}{V_g} \times 100 \quad \dots(1)$$

$$V_o = V_g - V_s \quad \dots(2)$$

Thus,

$$P = \frac{V_g - V_s}{V_g} \times 100 \quad \dots(3)$$

## 3.2 Principle

The determination of gas porosity is based on the measurement of the real volume of a sample, including the closed pores, by the use of a helium pycnometer.

NOTE — The theory of the gas pycnometer is given in annex A.

The following steps are carried out:

- drying the sample at 60 °C until a constant mass is reached;
- measurement of the geometrical volume of the sample;
- measurement of the real volume of the sample.

## 3.3 Apparatus

The apparatus necessary for open gas porosity measurement comprises the following.

**3.3.1 Oven**, for drying the sample at a temperature of  $(60 \pm 2)$  °C.

**3.3.2 Desiccator**, for cooling the sample before measuring its mass.

**3.3.3 Scale**, of capacity 0 to 5 kg and an accuracy of 0,01 %.

**3.3.4 Square caliper**, of accuracy 0,1 mm, for determining the geometrical volume of the sample.

**3.3.5 Gas pycnometer**, for measurement of the real sample volume, with a pressure accuracy of not less than 10 Pa.

## 3.4 Sample preparation

The samples shall be obtained either by moulding or by coring and cutting. Several examples of sample preparation are given in clause 2. Samples shall have a parallelepipedic or cylindrical configuration.

## 3.5 Procedure

### 3.5.1 Sample drying and weighing

Dry the samples at  $(60 \pm 2)$  °C in the oven (3.3.1) until constant mass is achieved. Constant mass is considered achieved when the difference between two mass values measured using the scale (3.3.3) at a 24 h interval is lower than 0,1 % of the value in the previous measurement. Before any measurement of mass, cool the samples to ambient temperature in the desiccator (3.3.2).

### 3.5.2 Determination of geometrical volume

Determine the geometrical volume ( $V_g$ ) immediately after the mass measurement.

#### 3.5.2.1 Cylinder diameter measurement

Use the square caliper (3.3.4) for the diameter measurement. Make four measurements at each end and in the middle for the sample, turning the sample 45° after each measurement. The average diameter ( $\bar{D}$ ) is the arithmetical mean of the twelve measured values.