



**SLOVENSKI STANDARD**  
**SIST ISO 11644:1998**

**01-april-1998**

---

**Usnje - Preskus vezave dodelavnih nanosov**

Leather -- Test for adhesion of finish

Cuir -- Essai de l'adhésion du finissage

ITEH STANDARD PREVIEW  
(standards.iteh.ai)

**Ta slovenski standard je istoveten z: ISO 11644:1993**

[SIST ISO 11644:1998](https://standards.iteh.ai/catalog/standards/sist/c8d9dd5e-e3eb-44ed-9a05-df3705c97783/sist-iso-11644-1998)

<https://standards.iteh.ai/catalog/standards/sist/c8d9dd5e-e3eb-44ed-9a05-df3705c97783/sist-iso-11644-1998>

**ICS:**

59.140.30      Usnje in krzno      Leather and furs

**SIST ISO 11644:1998**

**en**

**iTeh STANDARD PREVIEW**  
**(standards.iteh.ai)**

SIST ISO 11644:1998

<https://standards.iteh.ai/catalog/standards/sist/c8d9dd5e-e3eb-44ed-9a05-df3705c97783/sist-iso-11644-1998>

INTERNATIONAL  
STANDARD

**ISO**  
**11644**

**IULTCS/IUF**  
**470**

First edition  
1993-12-15

---

---

**Leather — Test for adhesion of finish**

*Cuir — Essai de l'adhésion du finissage*

**iTeh STANDARD PREVIEW**  
**(standards.iteh.ai)**

SIST ISO 11644:1998

<https://standards.iteh.ai/catalog/standards/sist/c8d9dd5e-e3eb-44ed-9a05-d3705c97783/sist-iso-11644-1998>



Reference number  
ISO 11644:1993 (E)  
IULTCS/IUF  
470, 1993 Edition

## ISO 11644:1993(E)

## Foreword

ISO (the International Organization for Standardization) is a worldwide federation of national standards bodies (ISO member bodies). The work of preparing International Standards is normally carried out through ISO technical committees. Each member body interested in a subject for which a technical committee has been established has the right to be represented on that committee. International organizations, governmental and non-governmental, in liaison with ISO, also take part in the work. ISO collaborates closely with the International Electrotechnical Commission (IEC) on all matters of electrotechnical standardization.

Draft International Standards adopted by the technical committees are circulated to the member bodies for voting. Publication as an International Standard requires approval by at least 75 % of the member bodies casting a vote.

International Standard ISO 11644 was prepared by the Fastness Tests Commission of the International Union of Leather Technologists and Chemists Societies (IUF Commission, IULTCS). It is based on IUF 470 published in *J. Soc. Leather Tech. Chem.*, **74**, pp. 155-160 (1990), and declared an official method of the IULTCS in September 1991.

Annexes A and B of this International Standard are for information only.

© ISO 1993

All rights reserved. Unless otherwise specified, no part of this publication may be reproduced or utilized in any form or by any means, electronic or mechanical, including photocopying and microfilm, without permission in writing from the publisher.

International Organization for Standardization  
Case Postale 56 • CH-1211 Genève 20 • Switzerland

Printed in Switzerland

## Introduction

A test method similar to that specified in this International Standard, using an epoxy adhesive and metal adherend-plates has been in use in the leather trade for many years, but has never been declared an official method by IULTCS or ISO. The adhesive frequently penetrates thin finish films, thus increasing the adhesion value unrealistically, and it is usually not possible to measure wet adhesion, as there is insufficient adhesion to the metal when water is present. Finishes with insufficient adhesion to the adhesive also occur quite frequently. In spite of these drawbacks, this old method has been used regularly and is referred to in many specifications. The new method specified in this International Standard eliminates most of these drawbacks.

The polyurethane adhesive used in the new method contains no solvent at the time of application to the finish and thus has a very high viscosity. It also stays viscous for only a few seconds, and there is no time for it to penetrate even very thin finishes, unless the finish has open cracks in it. While adhesion to most finishes is sufficient, a few cases exist in which adhesion is insufficient, and a different adhesive has to be used in such cases. As the adhesive does not penetrate, it is quite possible to test different layers of a multi-layer finish separately. Such a finish can be tested several times until all the layers have been removed from the leather. It would be advisable for specifications to make allowance for this fact.

A strip of hard PVC is used as the adherend-plate, this giving good adhesion under wet conditions. Wet adhesion can therefore be measured easily. Experience has shown that this "real" wet-adhesion value is often lower, a fact that should also be considered when drawing up specifications based on the new method.

**iTeh STANDARD PREVIEW**  
**(standards.iteh.ai)**

This page intentionally left blank

SIST ISO 11644:1998

<https://standards.iteh.ai/catalog/standards/sist/c8d9dd5e-e3eb-44ed-9a05-d3705c97783/sist-iso-11644-1998>

# Leather — Test for adhesion of finish

## 1 Scope

**1.1** Depending on the way the leather has been finished, the adhesion of the finish to the leather can be so low over the whole area, or part of it, that the finish separates from the leather during use. With finishes consisting of several layers, the separation may occur between the layers, for example between the pigmented layer and the base coat. This International Standard specifies a method for measuring the adhesion of the finish to the leather or the adhesion between two adjacent layers of the finish.

**1.2** The method is valid for all finished leathers with a smooth surface which can be bonded to an adherend-plate without the adhesive penetrating into the finish. Preliminary experiments may be necessary to determine whether these conditions obtain.

## 2 Normative references

The following standards contain provisions which, through reference in this text, constitute provisions of this International Standard. At the time of publication, the editions indicated were valid. All standards are subject to revision, and parties to agreements based on this International Standard are encouraged to investigate the possibility of applying the most recent editions of the standards indicated below. Members of IEC and ISO maintain registers of currently valid International Standards.

ISO 105-A02:1993, *Textiles — Tests for colour fastness — Part A02: Grey scale for assessing change in colour.*

ISO 2418:1972, *Leather — Laboratory samples — Location and identification.*

ISO 2419:1972, *Leather — Conditioning of test pieces for physical tests.*

ISO 3696:1987, *Water for analytical laboratory use — Specification and test methods.*

## 3 Definition

For the purposes of this International Standard, the following definition applies.

**3.1 adhesion:** The force required to pull the leather away from its surface finish layer, the force being applied steadily, at an angle of about 90° to a rigid adherend-plate to which the finished side of the leather has been bonded.

## 4 Principle

The finished side of part of a strip of leather is bonded to an adherend-plate by means of heat-reactivated adhesive film. Force is applied to the free end of the strip to peel the leather from the finish over a given distance, the finish layer remaining on the adherend-plate together with the film of adhesive. The force required is measured and reported as the adhesion of the finish to the leather.

The test is usually carried out on specimens conditioned in a standard atmosphere before testing. If required, the test may additionally be carried out on wetted specimens or on specimens which have previously been subjected to other agencies or preparations.

## 5 Apparatus and materials

**5.1 Tensile-testing machine**, operating vertically, incorporating the features specified in 5.1.1 to 5.1.4.

**5.1.1** An appropriate range of measurable loads.

**5.1.2** A speed of separation of the clamps of 100 mm/min  $\pm$  5 mm/min.

**5.1.3** Suitable means for fixing the adherend-plate holder (5.3) to the hook link (5.4).

**5.1.4** Provision for recording a force-distance diagram during the test.

**5.2 Adherend-plate**, comprising a piece of hard PVC<sup>1)</sup>, or other suitable material, measuring 70 mm × 20 mm × 3 mm, to which the leather specimen is bonded. PVC with a high IR absorption is preferred.

**5.3 Adherend-plate holder** (see figure 1), made for instance of aluminium, for holding the adherend-plate, to which the leather specimen has been bonded, in the lower clamp of the tensile-testing machine.

**5.4 Hook link**, made for instance of steel wire 1 mm to 2 mm in diameter, about 25 cm long, for attaching the free end of the leather specimen to the upper clamp of the tensile-testing machine (see figures 2 and 3).

**5.5 Punch**, suitable for making a hole 2 mm to 3 mm in diameter in the leather specimen.

**5.6 Two-component polyurethane adhesive<sup>2)</sup>**, comprising a resin and a hardener. Usually 20 g of solid resin is dissolved in 80 g of ethyl acetate and 5 g of hardener is added, unless otherwise instructed by the manufacturer of the adhesive. The adhesive shall be used within 8 h of addition of the hardener, unless otherwise instructed by the manufacturer of the adhesive.

**5.7 IR lamp**, capable of heating the adherend-plate (5.2) to 80 °C, or **oven**, capable of maintaining a temperature of 85 °C ± 3 °C, kept uniform by an air-circulation fan, for instance.

**5.8 Weight-piece**, of mass 4,5 kg, with a flat base.

**5.9 Temperature-indicating substance<sup>3)</sup>**, melting at 80 °C, to indicate when the surface temperature of the adherend-plate has reached 80 °C, when the IR lamp is being used.

**5.10 Cleaning solvent**: hexane or a mixture of alkanes boiling within the range 40 °C to 80 °C (e.g. petroleum ether), for cleaning the surface of the adherend-plate and the finished side of the leather specimen before bonding.

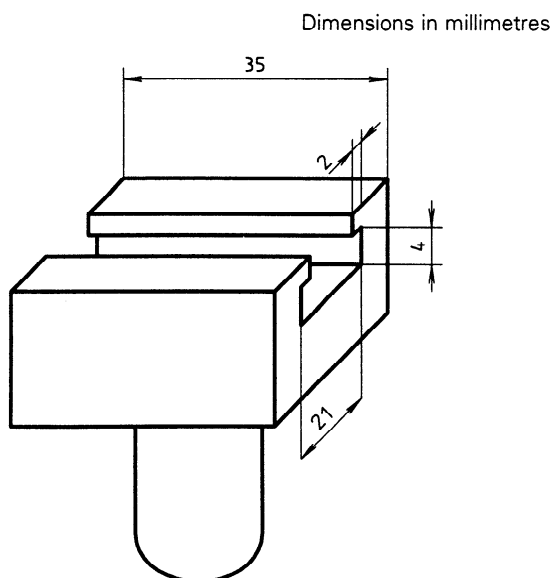

**Figure 1 — Adherend-plate holder**

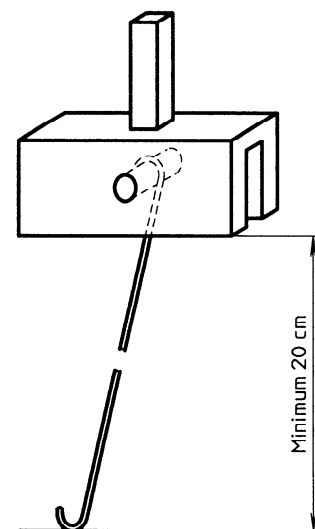

**Figure 2 — Hook link**

1) An example of a commercial source for suitable hard PVC plates is given in annex A.

2) An example of a commercial source for a suitable adhesive is given in annex A.

3) An example of a suitable temperature-indicating substance is given in annex A.



**5.11 Cutter**, capable of cutting a specimen of 100 mm × 10 mm from the leather with one stroke.

**5.12 Apparatus for wetting the test specimen**, comprising the elements specified in 5.12.1 to 5.12.3. (This is only required where wetted leathers are to be tested.)

**5.12.1 Vacuum-desiccator vessel**, or other glass container suitable for evacuation.

**5.12.2 Vacuum pump**, capable of evacuating the desiccator vessel (5.12.1) to 5 kPa (50 mbar) within 4 min.

**5.12.3 Beaker**, filled with distilled water at 20 °C in which the test specimens (leather bonded to adherend-plate) can be completely submerged.

**5.13 Grey scale for assessing change in colour**, in accordance with ISO 105-A02. (This is only required when the change in colour of the leather surface is to be assessed after undergoing the test and repolishing.)

**5.14 Demineralized water**, grade 3 in accordance with ISO 3696.

## 6 Preparation of test specimens

### 6.1 Location and number

From the piece of leather to be tested (or a laboratory sample cut from it, whichever is more suitable), cut out, with one stroke of the cutter (5.11), strips measuring 100 mm × 10 mm. If possible, the strip location shall be as specified in ISO 2418.

The adhesion of a finish to the leather may vary greatly, even within a single piece (skin, side, shoulder, etc.). It is therefore recommended that the leather specimens be taken not only from the positions specified in ISO 2418, but also from the shoulder and belly.

For each leather specimen location and each type of test specimen conditioning (usually at 20 °C and 65 % R.H. but, if required, also wetted, aged, etc.; see clause 7), take at least four leather specimens, two with their long axis parallel to and two with their long axis at right angles to the backbone.

### 6.2 Punching holes

Using the punch (5.5), make holes 2 mm to 3 mm in diameter at each end of the centreline of each strip, about 5 mm from the end.

### 6.3 Attachment of the leather specimen to the adherend-plate

**6.3.1** Clean the surface of the adherend-plate (5.2) to which the leather specimen is to be bonded and the finished side of the leather with a clean piece of cloth wetted with solvent (5.10).

**CAUTION — Use adequate ventilation and avoid contact of the solvent with the skin.**

**6.3.2** Apply the adhesive (5.6) as a thin layer to the cleaned surface of the adherend-plate with a brush, and then store at room temperature for at least 30 min. The adherend-plate with the adhesive shall be used within 8 h of application of the adhesive. Take care to apply the adhesive uniformly. For leathers with a coarse grain, several layers of adhesive shall be applied, in order to ensure that the grooves in the leather will be filled.

**6.3.3** Heat the adhesive film on the adherend-plate to 80 °C either with the IR lamp [before preparing test specimens, check, using a spare adherend-plate and the temperature-sensitive substance (5.9), that the IR lamp does in fact heat the plate to 80 °C] or by placing in the oven for 10 min at 85 °C. Immediately afterwards, place the leather specimen with the finish down on the adhesive film, with the leather extending about 15 mm beyond each end of the plate, and then place the weight-piece (5.8) on the leather for at least 2 min.

NOTE 1 Especially when testing the adhesion of the finish of leathers with heavy prints, even adhesion can be ensured by rolling the upper surface of the leather with a hand roller, applying moderate pressure, before the weight-piece is placed on the test specimen.

## 7 Conditioning of the test specimens

**7.1** The adhesion is normally determined on dry test specimens, conditioned in the standard atmosphere as described in 7.5. Whether, and the extent to which, other conditions have an effect on the adhesion can only be determined relative to the adhesion in the dry state.