

INTERNATIONAL
STANDARD

ISO
11677-2

First edition
1994-11-15

**Textile machinery and accessories — Main
dimensions of flat steel healds with open
end loops —**

Part 2:
(J-shaped end loops)

ISO 11677-2:1994

<https://standards.iteh.ai/en/standards/list/88ad2c11-1597-480b-b327-439560a77ed5/iso-11677-2-1994>
Matériel pour l'industrie textile — Dimensions principales des lisses en
acier plat avec boucles d'extrémités ouvertes —

Partie 2: Boucles d'extrémités en forme de «J»

INTERNATIONAL

ISO



Reference number
ISO 11677-2:1994(E)

Foreword

ISO (the International Organization for Standardization) is a worldwide federation of national standards bodies (ISO member bodies). The work of preparing International Standards is normally carried out through ISO technical committees. Each member body interested in a subject for which a technical committee has been established has the right to be represented on that committee. International organizations, governmental and non-governmental, in liaison with ISO, also take part in the work. ISO collaborates closely with the International Electrotechnical Commission (IEC) on all matters of electrotechnical standardization.

Draft International Standards adopted by the technical committees are circulated to the member bodies for voting. Publication as an International Standard requires approval by at least 75 % of the member bodies casting a vote.

International Standard ISO 11677-2 was prepared by Technical Committee ISO/TC 72, *Textile machinery and allied machinery and accessories*, Subcommittee SC 3, *Machinery for fabric manufacture*. [ISO 11677-2:1994](https://standards.iteh.ai/catalog/standards/sist/88ad2c1b-1597-480b-b327-105490000000/iso-11677-2:1994)

ISO 11677 consists of the following parts, under the general title *Textile machinery and accessories* — *Main dimensions of flat steel healds with open end loops*:

- Part 1: *C-shaped end loops*
- Part 2: *J-shaped end loops*

Textile machinery and accessories — Main dimensions of flat steel healds with open end loops —

Part 2:

J-shaped end loops

1 Scope

This part of ISO 11677 specifies the main dimensions and tolerances of flat steel healds with open end loops (J-shaped end loops) for use in the textile industry.

For main dimensions and tolerances of C-shaped end loops, see ISO 11677-1:1994, *Textile machinery and accessories — Main dimensions of flat steel healds with open end loops — Part 1: C-shaped end loops*.

2 Dimensions

<https://standards.iteh.ai/catalog/standards/sist/88ad2c1b-1597-480b-b327-42f05600a7cd/iso-11677-2-1994>

See figure 1 and table 1.

Dimensions in millimetres

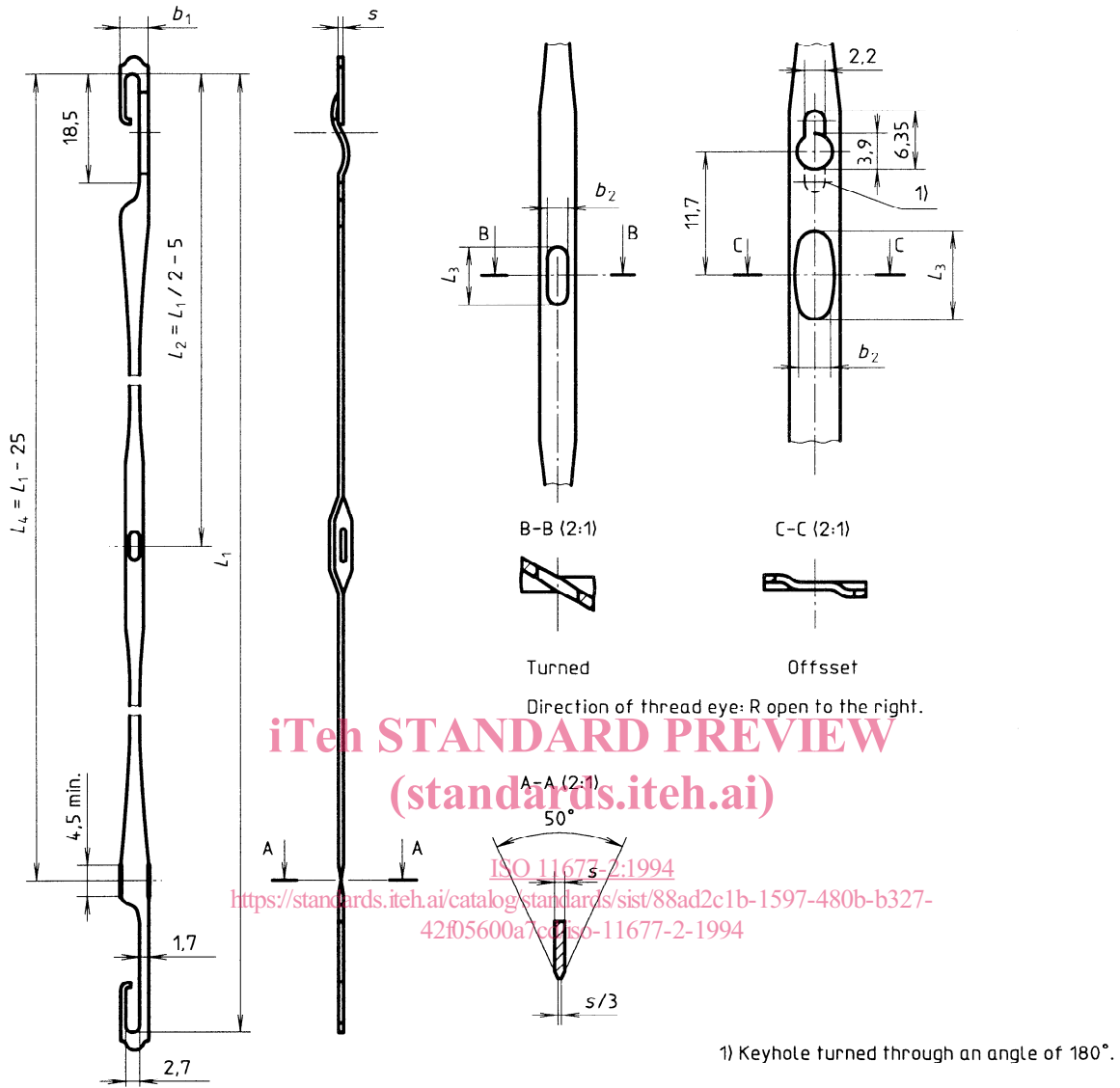

Figure 1

Table 1

Dimensions in millimetres

Cross-section of heald $b_1 \times s$	Dimensions of thread eye		Distance between end loops		
	L_3	b_2	L_1 1) $\pm 0,3$		
5,5 × 0,3	5,5	1,2	280	331	382
	6,5	1,8			
5,5 × 0,38	8	2,5	—	331	382
	8,4	3,8			

1) Derived from inch measurements.

iTeh STANDARD PREVIEW

This page intentionally left blank
(standards.iteh.ai)

ISO 11677-2:1994

<https://standards.iteh.ai/catalog/standards/sist/88ad2c1b-1597-480b-b327-42f05600a7cd/iso-11677-2-1994>

iTeh STANDARD PREVIEW

This page intentionally left blank
(standards.iteh.ai)

ISO 11677-2:1994

<https://standards.iteh.ai/catalog/standards/sist/88ad2c1b-1597-480b-b327-42f05600a7cd/iso-11677-2-1994>

iTeh STANDARD PREVIEW

This page intentionally left blank
(standards.iteh.ai)

ISO 11677-2:1994

<https://standards.iteh.ai/catalog/standards/sist/88ad2c1b-1597-480b-b327-42f05600a7cd/iso-11677-2-1994>

iTeh STANDARD PREVIEW
(standards.iteh.ai)

ISO 11677-2:1994

<https://standards.iteh.ai/catalog/standards/sist/88ad2c1b-1597-480b-b327-42f05600a7cd/iso-11677-2-1994>

ICS 59.120.30

Descriptors: textile machinery, accessories, healds, dimensions, dimensional tolerances.

Price based on 2 pages
