

TECHNICAL SPECIFICATION

SPECIFICATION TECHNIQUE



BASIC SAFETY PUBLICATION

PUBLICATION FONDAMENTALE DE SÉCURITÉ

Fire hazard testing –

Part 11-11: Test flames – Determination of the characteristic heat flux for ignition from a non-contacting flame source

Essais relatifs aux risques du feu –

Partie 11-11: Flamme d'essai – Détermination du flux de chaleur caractéristique pour l'allumage à partir d'une flamme source sans contact

<https://standards.iteh.ai/catalog/standards/iec/sub5/5e4d-ae11-4369-858f-8c99cbe841ad/iec-ts-60695-11-11-2016>



THIS PUBLICATION IS COPYRIGHT PROTECTED
Copyright © 2016 IEC, Geneva, Switzerland

All rights reserved. Unless otherwise specified, no part of this publication may be reproduced or utilized in any form or by any means, electronic or mechanical, including photocopying and microfilm, without permission in writing from either IEC or IEC's member National Committee in the country of the requester. If you have any questions about IEC copyright or have an enquiry about obtaining additional rights to this publication, please contact the address below or your local IEC member National Committee for further information.

Droits de reproduction réservés. Sauf indication contraire, aucune partie de cette publication ne peut être reproduite ni utilisée sous quelque forme que ce soit et par aucun procédé, électronique ou mécanique, y compris la photocopie et les microfilms, sans l'accord écrit de l'IEC ou du Comité national de l'IEC du pays du demandeur. Si vous avez des questions sur le copyright de l'IEC ou si vous désirez obtenir des droits supplémentaires sur cette publication, utilisez les coordonnées ci-après ou contactez le Comité national de l'IEC de votre pays de résidence.

IEC Central Office
3, rue de Varembe
CH-1211 Geneva 20
Switzerland

Tel.: +41 22 919 02 11
Fax: +41 22 919 03 00
info@iec.ch
www.iec.ch

About the IEC

The International Electrotechnical Commission (IEC) is the leading global organization that prepares and publishes International Standards for all electrical, electronic and related technologies.

About IEC publications

The technical content of IEC publications is kept under constant review by the IEC. Please make sure that you have the latest edition, a corrigenda or an amendment might have been published.

IEC Catalogue - webstore.iec.ch/catalogue

The stand-alone application for consulting the entire bibliographical information on IEC International Standards, Technical Specifications, Technical Reports and other documents. Available for PC, Mac OS, Android Tablets and iPad.

IEC publications search - www.iec.ch/searchpub

The advanced search enables to find IEC publications by a variety of criteria (reference number, text, technical committee,...). It also gives information on projects, replaced and withdrawn publications.

IEC Just Published - webstore.iec.ch/justpublished

Stay up to date on all new IEC publications. Just Published details all new publications released. Available online and also once a month by email.

Electropedia - www.electropedia.org

The world's leading online dictionary of electronic and electrical terms containing 20 000 terms and definitions in English and French with equivalent terms in 15 additional languages. Also known as the International Electrotechnical Vocabulary (IEV) online.

IEC Glossary - std.iec.ch/glossary

65 000 electrotechnical terminology entries in English and French extracted from the Terms and Definitions clause of IEC publications issued since 2002. Some entries have been collected from earlier publications of IEC TC 37, 77, 86 and CISPR.

IEC Customer Service Centre - webstore.iec.ch/csc

If you wish to give us your feedback on this publication or need further assistance, please contact the Customer Service Centre: csc@iec.ch.

A propos de l'IEC

La Commission Electrotechnique Internationale (IEC) est la première organisation mondiale qui élabore et publie des Normes internationales pour tout ce qui a trait à l'électricité, à l'électronique et aux technologies apparentées.

A propos des publications IEC

Le contenu technique des publications IEC est constamment revu. Veuillez vous assurer que vous possédez l'édition la plus récente, un corrigendum ou amendement peut avoir été publié.

Catalogue IEC - webstore.iec.ch/catalogue

Application autonome pour consulter tous les renseignements bibliographiques sur les Normes internationales, Spécifications techniques, Rapports techniques et autres documents de l'IEC. Disponible pour PC, Mac OS, tablettes Android et iPad.

Recherche de publications IEC - www.iec.ch/searchpub

La recherche avancée permet de trouver des publications IEC en utilisant différents critères (numéro de référence, texte, comité d'études,...). Elle donne aussi des informations sur les projets et les publications remplacées ou retirées.

IEC Just Published - webstore.iec.ch/justpublished

Restez informé sur les nouvelles publications IEC. Just Published détaille les nouvelles publications parues. Disponible en ligne et aussi une fois par mois par email.

Electropedia - www.electropedia.org

Le premier dictionnaire en ligne de termes électroniques et électriques. Il contient 20 000 termes et définitions en anglais et en français, ainsi que les termes équivalents dans 15 langues additionnelles. Egalement appelé Vocabulaire Electrotechnique International (IEV) en ligne.

Glossaire IEC - std.iec.ch/glossary

65 000 entrées terminologiques électrotechniques, en anglais et en français, extraites des articles Termes et Définitions des publications IEC parues depuis 2002. Plus certaines entrées antérieures extraites des publications des CE 37, 77, 86 et CISPR de l'IEC.

Service Clients - webstore.iec.ch/csc

Si vous désirez nous donner des commentaires sur cette publication ou si vous avez des questions contactez-nous: csc@iec.ch.

TECHNICAL SPECIFICATION

SPECIFICATION TECHNIQUE



BASIC SAFETY PUBLICATION

PUBLICATION FONDAMENTALE DE SÉCURITÉ

Fire hazard testing –

Part 11-11: Test flames – Determination of the characteristic heat flux for ignition from a non-contacting flame source

Essais relatifs aux risques du feu –

Partie 11-11: Flammes d'essai – Détermination du flux de chaleur caractéristique pour l'allumage à partir d'une flamme source sans contact

INTERNATIONAL
ELECTROTECHNICAL
COMMISSION

COMMISSION
ELECTROTECHNIQUE
INTERNATIONALE

ICS 13.220.40, 29.020

ISBN 978-2-8322-3177-7

**Warning! Make sure that you obtained this publication from an authorized distributor.
Attention! Veuillez vous assurer que vous avez obtenu cette publication via un distributeur agréé.**

CONTENTS

FOREWORD.....	4
INTRODUCTION.....	7
1 Scope.....	8
2 Normative references.....	8
3 Terms and definitions	8
4 Principle of the test.....	9
5 Apparatus.....	9
5.1 Test arrangement.....	9
5.2 Burner and test flame.....	10
5.3 Heat flux meter	10
5.4 Data acquisition system.....	11
5.5 Dummy test specimen board	11
5.6 Masking board	11
5.7 Timing device.....	12
5.8 Conditioning.....	12
5.9 Test specimen support	12
5.10 Burner support	12
5.11 Observation mirror	12
6 Test specimen	12
6.1 Specimen preparation	12
6.2 Test specimen dimensions	12
6.3 Testing ranges in formulations.....	13
6.3.1 General.....	13
6.3.2 Density, melt flows and filler/reinforcement	13
6.3.3 Colour	13
6.4 Conditioning of test specimens	13
7 Testing conditions	13
8 Test procedure	13
8.1 Determination of incident heat flux calibration curve	13
8.2 Determination of ignition times	14
8.3 Repetition of the test at different heat flux values.....	14
9 Evaluation of test results.....	15
9.1 Average ignition time \bar{t}_{ig}	15
9.2 Report format for CHFI	15
9.3 Precision data	15
10 Test report.....	15
Annex A (informative) An example of the calibration curve of incident heat flux versus the distance between the top of the burner tube and the lower surface of the test specimen.....	16
A.1 Calibration curves	16
Annex B (informative) Examples of ignition times with various materials of 3 mm thickness.....	18
B.1 Materials tested	18
Annex C (informative) Precision data.....	21
C.1 General.....	21

C.2	Heat flux versus distance at different Gas flow rates	21
C.3	Repeatability	22
C.4	Calculations and plots	23
Bibliography		25
Figure 1	– Arrangement and position of test specimen and burner	10
Figure 2	– Dummy test specimen board	11
Figure 3	– Structure of the masking board	12
Figure A.1	– Calibration curve (example)	16
Figure B.1	– Example of ignition times of PMMA	18
Figure B.2	– Ignition times for ABS (example)	19
Figure B.3	– Ignition times for HIPS (example)	19
Figure C.1	– Incident heat flux calibration curve (Gas flow rate = 105 cm ³ /min)	21
Figure C.2	– Incident heat flux calibration curve (Gas flow rate = 160 cm ³ /min)	22
Figure C.3	– 1/t _{ig} for Material A	23
Figure C.4	– 1/t _{ig} for Material B	23
Figure C.5	– 1/t _{ig} for Material C	24
Figure C.6	– 1/t _{ig} for Material D	24
Table A.1	– Calibration data (examples of actual measured data as shown in Figure A.1)	17
Table A.2	– Calibration data (examples of interpolated values)	17
Table B.1	– Illustrative example of tabulated results	20
Table C.1	– Precision data of ignition time	22

INTERNATIONAL ELECTROTECHNICAL COMMISSION

FIRE HAZARD TESTING –

Part 11-11: Test flames – Determination of the characteristic heat flux for ignition from a non-contacting flame source

FOREWORD

- 1) The International Electrotechnical Commission (IEC) is a worldwide organization for standardization comprising all national electrotechnical committees (IEC National Committees). The object of IEC is to promote international co-operation on all questions concerning standardization in the electrical and electronic fields. To this end and in addition to other activities, IEC publishes International Standards, Technical Specifications, Technical Reports, Publicly Available Specifications (PAS) and Guides (hereafter referred to as "IEC Publication(s)"). Their preparation is entrusted to technical committees; any IEC National Committee interested in the subject dealt with may participate in this preparatory work. International, governmental and non-governmental organizations liaising with the IEC also participate in this preparation. IEC collaborates closely with the International Organization for Standardization (ISO) in accordance with conditions determined by agreement between the two organizations.
- 2) The formal decisions or agreements of IEC on technical matters express, as nearly as possible, an international consensus of opinion on the relevant subjects since each technical committee has representation from all interested IEC National Committees.
- 3) IEC Publications have the form of recommendations for international use and are accepted by IEC National Committees in that sense. While all reasonable efforts are made to ensure that the technical content of IEC Publications is accurate, IEC cannot be held responsible for the way in which they are used or for any misinterpretation by any end user.
- 4) In order to promote international uniformity, IEC National Committees undertake to apply IEC Publications transparently to the maximum extent possible in their national and regional publications. Any divergence between any IEC Publication and the corresponding national or regional publication shall be clearly indicated in the latter.
- 5) IEC itself does not provide any attestation of conformity. Independent certification bodies provide conformity assessment services and, in some areas, access to IEC marks of conformity. IEC is not responsible for any services carried out by independent certification bodies.
- 6) All users should ensure that they have the latest edition of this publication.
- 7) No liability shall attach to IEC or its directors, employees, servants or agents including individual experts and members of its technical committees and IEC National Committees for any personal injury, property damage or other damage of any nature whatsoever, whether direct or indirect, or for costs (including legal fees) and expenses arising out of the publication, use of, or reliance upon, this IEC Publication or any other IEC Publications.
- 8) Attention is drawn to the Normative references cited in this publication. Use of the referenced publications is indispensable for the correct application of this publication.
- 9) Attention is drawn to the possibility that some of the elements of this IEC Publication may be the subject of patent rights. IEC shall not be held responsible for identifying any or all such patent rights.

The main task of IEC technical committees is to prepare International Standards. In exceptional circumstances, a technical committee may propose the publication of a technical specification when

- the required support cannot be obtained for the publication of an International Standard, despite repeated efforts, or
- the subject is still under technical development or where, for any other reason, there is the future but no immediate possibility of an agreement on an International Standard.

Technical specifications are subject to review within three years of publication to decide whether they can be transformed into International Standards.

IEC TS 60695-11-11, which is a technical specification, has been prepared by IEC technical committee 89: Fire hazard testing.

It has the status of a basic safety publication in accordance with IEC Guide 104 and ISO/IEC Guide 51.

This second edition of IEC TS 60695-11-11 cancels and replaces the first edition published in 2008. It constitutes a technical revision.

This edition includes the following significant technical changes with respect to the previous edition:

- a) Fix of editorials throughout the text;
- b) Introduction updated;
- c) Normative references updated;
- d) Results of recent round-robin testing incorporated; and
- e) Informative Annex C "Precision data" added.

The text of this technical specification is based on the following documents:

Enquiry draft	Report on voting
89/1227/DTS	89/1248/RVC

Full information on the voting for the approval of this technical specification can be found in the report on voting indicated in the above table.

This publication has been drafted in accordance with the ISO/IEC Directives, Part 2.

This technical specification is to be used in conjunction with IEC 60695-11-4.

A list of all the parts in the IEC 60695 series, under the general title *Fire hazard testing*, can be found on the IEC website.

Part 11 consists of the following parts:

- Part 11-2: Test flames – 1 kW nominal pre-mixed flame – Apparatus, confirmatory test arrangement and guidance
- Part 11-3: Test flames – 500 W flames – Apparatus and confirmational test methods
- Part 11-4: Test flames – 50 W flame – Apparatus and confirmational test method
- Part 11-5: Test flames – Needle-flame test method – Apparatus, confirmatory test arrangement and guidance
- Part 11-10: Test flames – 50 W horizontal and vertical flame test methods
- Part 11-11: Test flames – Determination of the characteristic heat flux for ignition from a non-contacting flame source
- Part 11-20: Test flames – 500 W flame test methods
- Part 11-21: Test flames – 500 W vertical flame test method for tubular polymeric materials
- Part 11-30: Test flames – History and development from 1979 to 1999
- Part 11-40: Test flames – Confirmatory tests – Guidance

The committee has decided that the contents of this publication will remain unchanged until the stability date indicated on the IEC website under "<http://webstore.iec.ch>" in the data related to the specific publication. At this date, the publication will be

- transformed into an International standard,
- reconfirmed,
- withdrawn,
- replaced by a revised edition, or
- amended.

IMPORTANT – The “colour inside” logo on the cover page of this publication indicates that it contains colours which are considered to be useful for the correct understanding of its contents. Users should therefore print this publication using a colour printer.

iTech Standards
(<https://standards.itih.ai>)
Document Preview

IEC TS 60695-11-11:2016

<https://standards.itih.ai/catalog/standards/iec/ab575eud-ae11-4369-858f-8c99cbe841ad/iec-ts-60695-11-11-2016>

WITHDRAWN

INTRODUCTION

In the design of any electrotechnical product, the risk of fire and the potential hazards associated with fire need to be considered. In this respect the objective of component, circuit and equipment design as well as the choice of materials is to reduce the risk of fire to a tolerable level even in the event of reasonably foreseeable (mis)use, malfunction or failure. IEC 60695-1-10, together with its companion, IEC 60695-1-11, provide guidance on how this is to be accomplished.

Fires involving electrotechnical products can be initiated from external non-electrical sources. Considerations of this nature are dealt with in an overall fire hazard assessment.

The aim of the IEC 60695 series of standards is to save lives and property by reducing the number of fires or reducing the consequences of the fire. This can be accomplished by

- trying to prevent ignition caused by an electrically energised component part and, in the event of ignition, to confine any resulting fire within the bounds of the enclosure of the electrotechnical product.
- trying to minimise flame spread beyond the product's enclosure and to minimise the harmful effects of fire effluents including heat, smoke, and toxic or corrosive combustion products.

This technical specification is to be used to measure and describe the properties of materials used for electrotechnical products and sub-assemblies in response to heat from a non-contacting flame source under controlled laboratory conditions and is to not be used to describe or appraise the fire hazard or fire risk of materials, products, or assemblies under actual fire conditions. However, results of this test can be used as elements of a fire hazard assessment which takes into account all of the factors which are pertinent to an assessment of the fire hazard of a particular end use. A test specimen cut from end-product or sub-assembly can be tested by this test method.

This technical specification may involve hazardous materials, operations, and equipment. It does not purport to address all of the safety problems associated with its use. It is the responsibility of the user to establish appropriate safety and health practices and determine the applicability of regulatory limitations prior to use.

Test methods to determine flammability by contact of flame have been developed and standardized already, such as IEC 60695-11-10 [1]¹ and IEC 60695-11-20 [2]¹ and ISO 4589-2 [3]¹.

This is the first test method to determine the characteristic heat flux for ignition (CHF_I) of materials used for electrotechnical products and sub-assemblies from a non-contacting flame source. CHF_I characterizes ignition behaviour in terms of incident heat flux. This test method simulates the fire behaviour of materials used for electrotechnical products where a flame source exists close to, but does not contact with these items. An example is a candle flame near an electrotechnical product.

¹ Numbers in square brackets refer to the bibliography.

FIRE HAZARD TESTING –

Part 11-11: Test flames – Determination of the characteristic heat flux for ignition from a non-contacting flame source

1 Scope

This part of IEC 60695, which is a technical specification describes a test method used to determine the characteristic heat flux for ignition (CHF_I) from a non-contacting flame source for materials used in electrotechnical products and sub-assemblies. It provides a relationship between ignition time and incident heat flux. A test specimen cut from an end-product or sub-assembly can be tested by this test method.

This basic safety publication is intended for use by technical committees in the preparation of standards in accordance with the principles laid down in IEC Guide 104 and ISO/IEC Guide 51.

One of the responsibilities of a technical committee is, wherever applicable, to make use of basic safety publications in the preparation of its publications. The requirements, test methods or test conditions of this basic safety publication will not apply unless specifically referred to or included in the relevant publications.

2 Normative references

The following documents, in whole or in part, are normatively referenced in this document and are indispensable for its application. For dated references, only the edition cited applies. For undated references, the latest edition of the referenced document (including any amendments) applies.

IEC 60695-11-4, *Fire hazard testing – Part 11-4: Test flames – 50 W flame – Apparatus and confirmational test method*

IEC Guide 104, *The preparation of safety publications and the use of basic safety publications and group safety publications*

ISO/IEC Guide 51:1999, *Safety aspects – Guidelines for their inclusion in standards*

ISO 291, *Plastics – Standard atmospheres for conditioning and testing*

ISO 293, *Plastics – Compression moulding of test specimens of thermoplastic materials*

ISO 294 (all parts), *Plastics – Injection moulding of test specimens of thermoplastic materials*

ISO 295, *Plastics – Compression moulding of test specimens of thermosetting materials*

ISO 13943:2008, *Fire safety – Vocabulary*

ISO 14934-4:2014, *Fire tests – Calibration of heat flux meters – Part 4: Guidance on the use of heat flux meters in fire tests*

3 Terms and definitions

For the purposes of this document, the terms and definitions given in ISO 13943:2008, some of which are reproduced below for the user's convenience, as well as the following apply.

3.1

average ignition time, \bar{t}_{ig}

arithmetic mean of three ignition times measured at a given heat flux

3.2 characteristic heat flux for ignition CHFI

maximum incident heat flux which is a multiple of 5 kW/m² and at which \bar{t}_{ig} is greater than 120 s

3.3 draught-free environment

space in which the results of experiments are not significantly affected by the local air speed

Note 1 to entry: A qualitative example is a space in which a wax candle flame remains essentially undisturbed. Quantitative examples are small-scale fire tests in which a maximum air speed of 0,1 m/s or 0,2 m/s is sometimes specified.

[SOURCE: ISO 13943:2008, 4.70]

3.4 heat flux

amount of thermal energy emitted, transmitted or received per unit area and per unit time

Note 1 to entry: The typical units are watts per square metre (W/m²).

[SOURCE: ISO/IEC 13943:2008, 4.173]

3.5 ignition

initiation of combustion which results in a sustained flaming combustion for at least 5 s

Note 1 to entry: The term "ignition" in French has a very different meaning [state of body combustion].

3.6 incident heat flux

heat flux received by the surface of a test specimen

[SOURCE: IEC 60695-4:2012, 3.2.15]

4 Principle of the test

The incident heat flux is measured using the apparatus described in 5.3 and 5.4. The incident heat flux value is controlled by changing the distance between the top of the burner tube and the lower surface of the test specimen and by changing the flow rate of gas to the burner (See Annex A). The time required to ignite the test specimen is measured as a function of the incident heat flux. The tests are performed at different incident heat flux values until the maximum heat flux, at which \bar{t}_{ig} is greater than 120 s and defined as the characteristic heat flux for ignition (CHFI) is obtained. The incident heat flux values at which the tests are carried out are chosen within the range of 30 kW/m² to 75 kW/m² and shall be a multiple of 5 kW/m².

5 Apparatus

5.1 Test arrangement

The arrangement and position of the test specimen and burner are shown in Figure 1. The test specimen and masking board shall be mounted horizontally. The burner tube shall be mounted vertically. The centre line of the test specimen, the burner tube, the sensor of the heat flux meter and the conical hole in the masking board shall all be aligned vertically. The sensor of the heat flux meter shall be placed horizontally 6 mm above the upper surface of the masking board with its sensing surface facing down.

Dimensions in millimetres

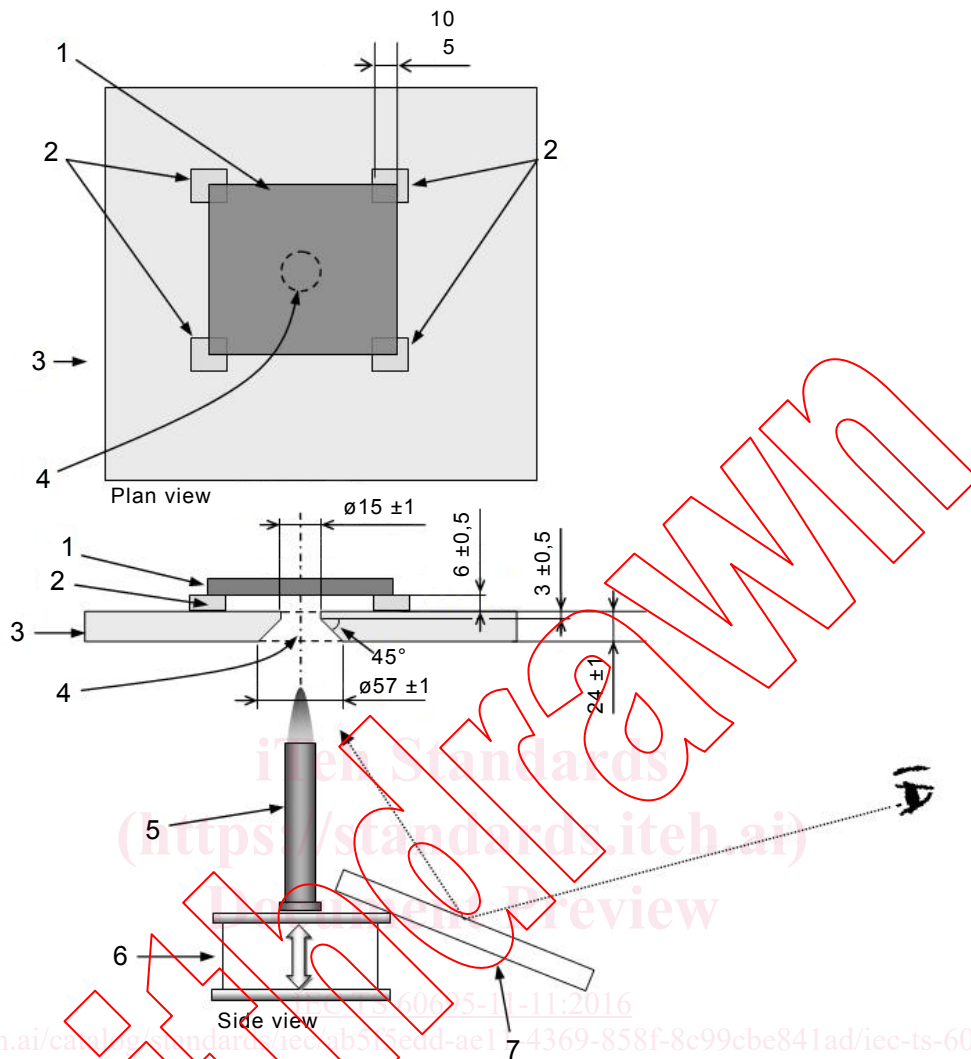

Key

- 1 Test specimen
- 2 Test specimen support
- 3 Masking board
- 4 Conical hole (diameter at the top side 15 mm)
- 5 Burner tube and test flame (inner diameter 9,5 mm)
- 6 Burner support (adjustable vertically)
- 7 Mirror

Figure 1 – Arrangement and position of test specimen and burner

5.2 Burner and test flame

The laboratory burner apparatus shall conform to IEC 60695-11-4. The flame size and the gas flow rate will differ from that specified in IEC 60695-11-4 in order to obtain the heat flux value necessary for the test. The flame used for each test shall be maintained throughout the test.

NOTE ISO 10093 [4] describes the burner as ignition source P/PF2 (50 W).

5.3 Heat flux meter

The heat flux meter shall be of a water-cooled thermopile type (see ISO 14934-4:2014) which determines the incident heat flux applied to the test specimen.

When incident heat flux measurements are made, the heat flux meter is placed in the centre of a dummy test specimen board, and the heat flux meter shall not have any optical filter in-line with the sensor.

NOTE 1 The incident heat flux measurement is of critical importance to the test results. ISO 14934-3 [5] provides the calibration method for the heat flux meter.

NOTE 2 A thermopile of the Schmidt-Boelter type, with a designed range up to 100 kW/m² and a target diameter of approximately 12,5 mm, has been found to be suitable.

5.4 Data acquisition system

The voltmeter for measuring the output of the heat flux meter shall have a resolution of 0,01 % or better for the maximum output range.

5.5 Dummy test specimen board

The dummy test specimen board shall be approximately 75 mm × 75 mm × 12 mm with a centrally located hole whose diameter is slightly larger than the outside diameter of the heat flux meter. The board shall be made from a heat-resistant non-combustible rigid board. The dummy specimen board is used, together with the heat flux meter (see Figure 2), for the determination of incident heat flux (see 8.1).

NOTE A calcium silicate board of approximately 12 mm thickness having dry density of approximately 900 kg/m³ has been found suitable for the dummy test specimen board.

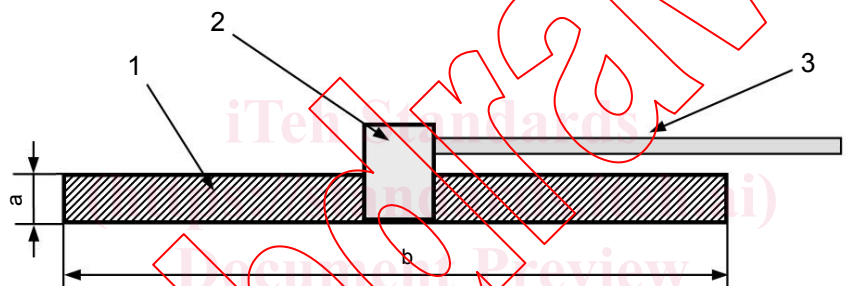

IEC

Key

- 1 Dummy test specimen board
- 2 Heat flux meter
- 3 Cooling water pipe
- a Approximately 12 mm
- b Approximately 100 mm

Figure 2 – Dummy test specimen board

5.6 Masking board

The masking board shall be made of three heat-resistant non-combustible rigid boards, each having a density of 850 kg/m³ ± 50 kg/m³ and a thickness of 8 mm ± 0,5 mm and the total thickness of the three non-combustible board shall be 24 mm ± 1,5 mm. One board is inserted between the upper and lower boards and is made moveable. This moveable board is the radiant heat shield which protects the test specimen from the heat source before the test is started. At the centre of the masking board there shall be a conically shaped opening. The diameter of the opening on the upper surface shall be 15 mm ± 1 mm and 57 mm ± 1 mm on the lower surface. An illustration of the masking board and its operation is shown in Figure 3.

NOTE A calcium silicate board of the required density has a thermal conductivity of 0,14 W/m/K at 200 °C, 0,15 W/m/K at 400 °C, and 0,17 W/m/K at 600 °C.

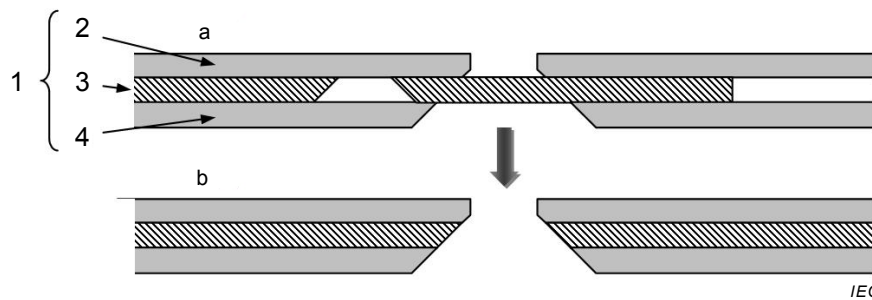

Key

- 1 Masking board
- 2 Upper board
- 3 Moveable board (Radiant heat shield)
- 4 Lower board
- a Position of the moveable masking board prior to a test
- b Position of the moveable masking board during a test

Figure 3 – Structure of the masking board

5.7 Timing device

The timing device shall have a resolution of 0,5 s or better.

5.8 Conditioning

The conditioning chamber shall be maintained at a temperature of 23 °C ± 2 °C, with a relative humidity of 50 % ± 10 % (see ISO 291).

5.9 Test specimen support

The test specimen support shall maintain a distance of 6 mm ± 0,5 mm between the lower surface of the test specimen and the upper surface of the masking board.

5.10 Burner support

The burner shall be located on a support which can be adjusted in the vertical direction. The distance between the top of the burner tube and the lower surface of the test specimen shall be able to be determined using a suitable measuring device which has a resolution of 1 mm or better.

5.11 Observation mirror

To observe the ignition behaviour of the test specimen, an observation mirror approximately 100 mm × 100 mm shall be positioned underneath the masking board.

6 Test specimen

6.1 Specimen preparation

Test specimens shall be fabricated using the appropriate ISO method, e.g. casting and injection moulding in accordance with ISO 294, compression moulding in accordance with ISO 293 or ISO 295, or transfer moulding to the necessary shape. Where this is not possible, the test specimen shall be produced using the same fabrication process as would be normally used to mould a part of a product; and where this is not possible, specimens are to be cut from a representative sample of the moulded material taken from an end product.

After any cutting operation, care shall be taken to remove all dust and any particles from the surface; cut edges shall be fine sanded to a smooth finish.

6.2 Test specimen dimensions

The dimensions of the planar sections of the test specimens shall be at least 77,5 mm ± 2,5 mm in length and width and at the thickness under consideration. The