



SLOVENSKI STANDARD
SIST ISO 11687-1:2002
01-marec-2002

8 fgb]`YÿUJ!`Dc_cb bJ`YÿUJ!`%`XY.`C_fcj `dc_cb bY[U`YÿUU

Plain bearings -- Pedestal plain bearings -- Part 1: Pillow blocks

Paliers lisses -- Paliers lisses à chaise sur le sol -- Partie 1: Supports de paliers

Ta slovenski standard je istoveten z: ISO 11687-1:1995

[SIST ISO 11687-1:2002](https://standards.iteh.ai/catalog/standards/sist/1e9dc6f5-e1db-47b2-bff5-7d7c9f3e499/sist-iso-11687-1-2002)

<https://standards.iteh.ai/catalog/standards/sist/1e9dc6f5-e1db-47b2-bff5-7d7c9f3e499/sist-iso-11687-1-2002>

ICS:

21.100.10 Drsni ležaji Plain bearings

SIST ISO 11687-1:2002 **en**

iTeh STANDARD PREVIEW
(standards.iteh.ai)

[SIST ISO 11687-1:2002](https://standards.iteh.ai/catalog/standards/sist/1e9dc6f5-e1db-47b2-bff5-7d7c93e499/sist-iso-11687-1-2002)

<https://standards.iteh.ai/catalog/standards/sist/1e9dc6f5-e1db-47b2-bff5-7d7c93e499/sist-iso-11687-1-2002>

INTERNATIONAL
STANDARD

ISO
11687-1

First edition
1995-02-01

**Plain bearings — Pedestal plain
bearings —**

Part 1:
Pillow blocks

iTeh STANDARD PREVIEW
(standards.iteh.ai)

Paliers lisses — Paliers lisses à chaise sur le sol —

Partie 1: Supports de paliers
<https://standards.iteh.ai/catalog/standards/sist/11687-1-2002>
<https://standards.iteh.ai/catalog/standards/sist/11687-1-2002>



Reference number
ISO 11687-1:1995(E)

ISO 11687-1:1995(E)**Foreword**

ISO (the International Organization for Standardization) is a worldwide federation of national standards bodies (ISO member bodies). The work of preparing International Standards is normally carried out through ISO technical committees. Each member body interested in a subject for which a technical committee has been established has the right to be represented on that committee. International organizations, governmental and non-governmental, in liaison with ISO, also take part in the work. ISO collaborates closely with the International Electrotechnical Commission (IEC) on all matters of electrotechnical standardization.

Draft International Standards adopted by the technical committees are circulated to the member bodies for voting. Publication as an International Standard requires approval by at least 75 % of the member bodies casting a vote.

International Standard ISO 11687-1 was prepared by Technical Committee ISO/TC 123, *Plain bearings*, Subcommittee SC 3, *Dimensions, tolerances and construction details*.

ISO 11687 consists of the following parts, under the general title *Plain bearings — Pedestal plain bearings*:

- Part 1: *Pillow blocks*
- Part 2: *Side flange bearings*
- Part 3: *Centre flange bearings*

© ISO 1995

All rights reserved. Unless otherwise specified, no part of this publication may be reproduced or utilized in any form or by any means, electronic or mechanical, including photocopying and microfilm, without permission in writing from the publisher.

International Organization for Standardization
Case Postale 56 • CH-1211 Genève 20 • Switzerland

Printed in Switzerland

Plain bearings — Pedestal plain bearings —

Part 1: Pillow blocks

1 Scope

This part of ISO 11687 specifies design characteristics for pillow blocks for size ranges 9 to 28 and 35 to 71, as well as design characteristics for shafts.

It is applicable to pillow blocks used mainly in electrical and turbo engineering industries.

ISO 630:1980, *Structural steels*.

ISO 683-11:1987, *Heat-treatable steels, alloy steels and free-cutting steels — Part 11: Wrought case-hardening steels*.

ISO 1302:1992, *Technical drawings — Method of indicating surface texture*.

2 Normative references

The following standards contain provisions which, through reference in this text, constitute provisions of this part of ISO 11687. At the time of publication, the editions indicated were valid. All standards are subject to revision, and parties to agreements based on this part of ISO 11687 are encouraged to investigate the possibility of applying the most recent editions of the standards indicated below. Members of IEC and ISO maintain registers of currently valid International Standards.

ISO 185:1988, *Grey cast iron — Classification*.

ISO 426-1:1983, *Wrought copper-zinc alloys — Chemical composition and forms of wrought products — Part 1: Non-leaded and special copper-zinc alloys*.

ISO 426-2:1983, *Wrought copper-zinc alloys — Chemical composition and forms of wrought products — Part 2: Leaded copper-zinc alloys*.

ISO 2768-1:1989, *General tolerances — Part 1: Tolerances for linear and angular dimensions without individual tolerance indications*.

ISO 2768-2:1989, *General tolerances — Part 2: Geometrical tolerances for features without individual tolerance indications*.

ISO 3755:1991, *Cast carbon steels for general engineering purposes*.

ISO 4381:1991, *Plain bearings — Lead and tin casting alloys for multilayer plain bearings*.

ISO 8062:1994, *Castings — System of dimensional tolerances and machining allowances*.

ISO 12129-1:—¹⁾, *Plain bearings — Part 1: Fits*.

ISO 12129-2:—¹⁾, *Plain bearings — Part 2: Tolerances on form and position and surface roughness for shafts, flanges and thrust collars*.

1) To be published.

3 Types of pillow block

According to their design, pillow blocks can be devised as follows, each characteristic being designated by a letter symbol.

Housing:

- G Pillow block, without cooling fins
- R Pillow block, with cooling fins

Heat dissipation:

- N Natural cooling
- W Water cooling in oil sump
- U Circulation pump and natural cooling
- T Circulation pump and water cooling in oil sump
- Z Recirculating oil lubrication with external cooling of oil

Shape of bore for journal bearing and type of lubrication:

- C Circular cylindrical bore without oil ring
- L Circular cylindrical bore with split oil ring not fixed on a rotating shaft
- Y Lobed bearing with two sliding surfaces without oil ring
- V Lobed bearing with four sliding surfaces without oil ring

Thrust bearing:

- Q Without sliding surfaces [non-locating (free) bearing]
 - B Plain sliding surfaces with oil grooves (guide bearing)
 - K Wedge surfaces
 - A Tilting pads
- } (design and dimensions at the manufacturer's discretion)

Seal:

Type and dimensions subject to agreement

Figures 1 and 2 show examples of pillow blocks. These represent pillow blocks, which are ready to be installed, in the size ranges 9 to 28 and 35 to 71, respectively.

The symbols above figures 1 and 2 explain only the type illustrated; the complete type required shall be specified in the above-mentioned sequence when ordering.

For reasons of design (e.g. on account of limited space) and economy, it is only possible to construct the size range 35 to 71 with thrust bearings (A) with the dimensions given in table 3.

4 Dimensions

See figures 1 to 4 and tables 1 to 4.

The pillow blocks are not expected to conform to the designs illustrated in figures 1 and 2; compliance is only required with respect to the dimensions specified.

NOTE 1 All dimensions are given in millimetres

Details which are not specified shall be chosen as appropriate.

5 Shaft design

See figures 3 and 4 and tables 3 and 4.

6 Materials

Housing:

Grade 300 in accordance with ISO 185; other materials subject to agreement

Half-bearing:

Bearing back:

- Fe 360 B in accordance with ISO 630
- C10 or C15 E 4 in accordance with ISO 683-11
- 200 to 400 in accordance with ISO 3755

} Type of material at the manufacturer's discretion

Bearing metal:

Lead-tin-alloy in accordance with ISO 4381, or subject to agreement

Seal:

Copper alloy, aluminium alloy or plastic, subject to agreement

Oil ring, not fixed on rotating shaft:

Copper-zinc alloy in accordance with ISO 426, or subject to agreement

7 Design

General tolerances:

For machined surfaces:

ISO 2768-1 and ISO 2768-2 - mH

For unmachined surfaces:

ISO 8062 - CT 9 (for grade 300), or corresponding standards for other materials agreed upon.

Surface roughness in accordance with ISO 1302:

Pillow block:

Mounted surfaces: $R_a = 3,2 \mu\text{m}$

Sliding surfaces: $R_a = 0,8 \mu\text{m}$

Shaft:

See tables 3 and 4, footnote 1.

Housing:

Pillow block housing with lifting eye bolts or means of conveyance at the manufacturer's discretion.

The inner surfaces of the housing shall be clean and shall have a coat of paint resistant to oil and solvents.

The outer surfaces of the housing shall be protected against corrosion.

For the purpose of pressure compensation, the individual oil spaces within the pillow block housing shall be connected to each other by means of appropriate openings above the oil level.

All bearing housing connections on both sides; other connecting dimensions and arrangements than those given in figures 1 and 2 as well as additional connections subject to agreement.

Type of inspection plate at the manufacturer's discretion.

With two pull-off screws at housing base at the manufacturer's discretion.

With bolts and screws for housing parts and seals, at the manufacturer's discretion.

Bolts and screws and dowel pins for the housing base do not form part of the delivery.

General:

Particular agreements shall be made for applications under special conditions (e.g. inclined positions).

Chamfered edges: type of edge chamfering at the manufacturer's discretion.

If the bearing is only applicable to one direction of rotation, a directional arrow shall be provided.

iTeh STANDARD PREVIEW
(standards.iteh.ai)

SIST ISO 11687-1:2002

<https://standards.iteh.ai/catalog/standards/sist/1e1c6511-11687-1-2002-bff5-11687-1-2002>

8 Designation

EXAMPLE

Designation of a pillow block of size 14, shaft diameter 125 mm, housing with cooling fins (R), for recirculating oil lubrication with external cooling of oil (Z), circular cylindrical bore with split oil ring not fixed on a rotating shaft for emergency run (L) and thrust bearing with wedge surfaces (K):

Pillow block ISO 11687-1 - 14 - 125 - RZLK

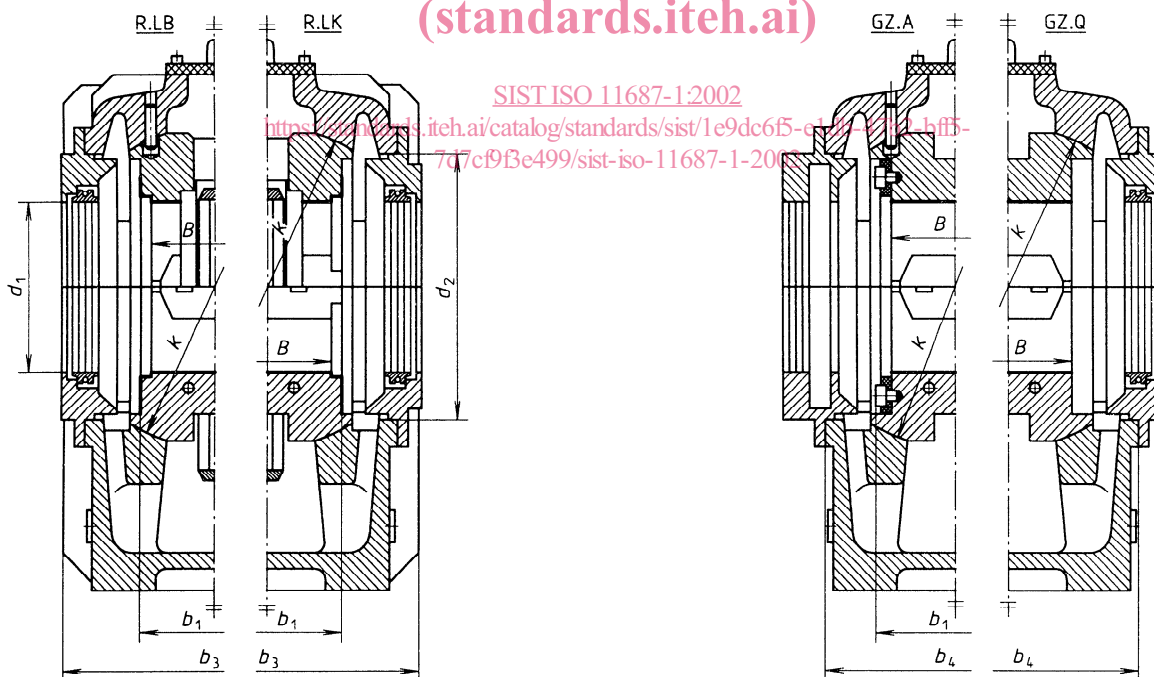
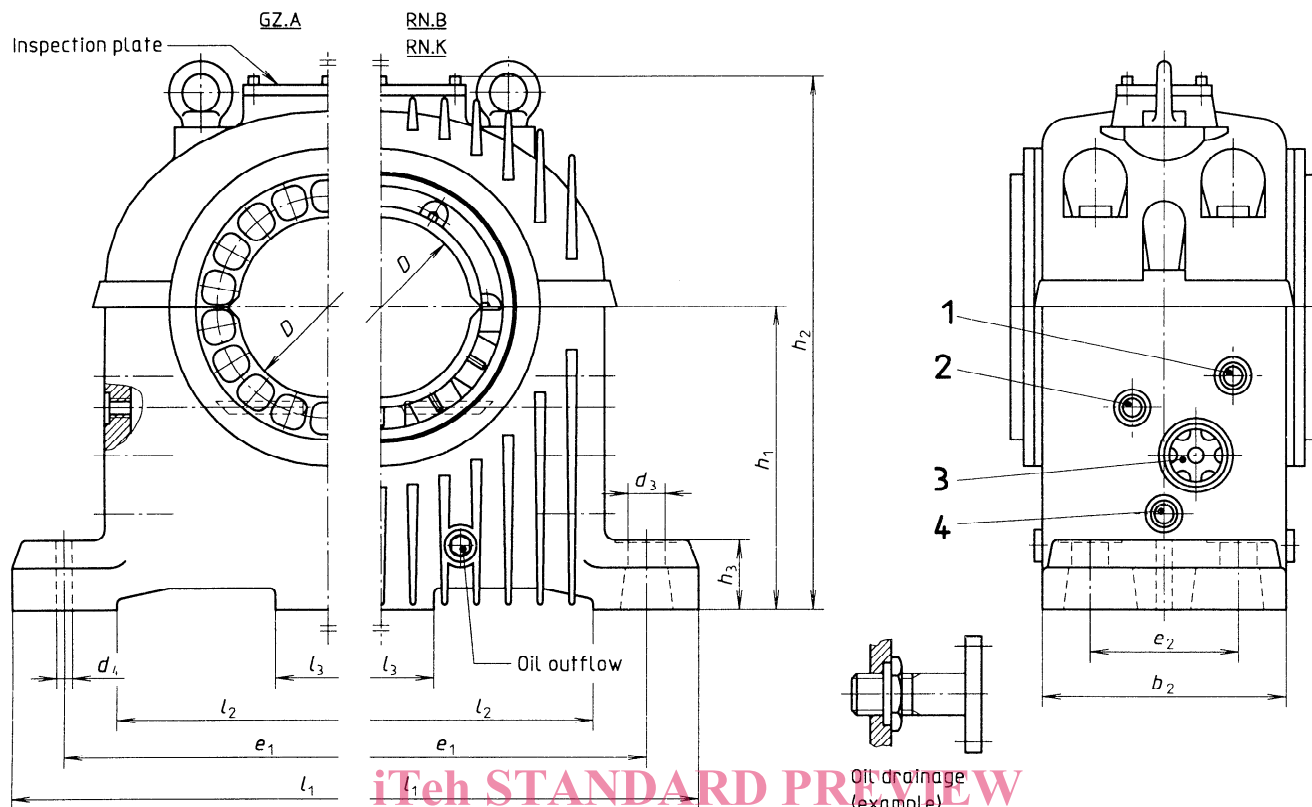

Key

- 1 d_5 Oil inlet (recirculating plant, circulation pump)
- 2 Thread G 1/2 Connection for thermoprobe
- 3 d_6 Oil-level indicator or oil drainage for recirculating plant
- 4 Screw plug (connection for radiator, oil-sump thermometer, suction line of circulation pump, finned cooler)

Figure 1 — Examples of pillow blocks — Size range 9 to 28

Table 1 — Pillow blocks — Size range 9 to 28 (see figure 1)

Size	9			11			14			18			22			28			
	H7 ¹⁾	80	90	100	100	110	125	125	140	160	160	180	200	200	225	250	250	280	300
B ²⁾		60			80			105			135			170			215		
b_1		80			100			125			160			200			250		
b_2		145			165			205			245			310			370		
b_3		190			205			255			300			380			450		
b_4		150			170			215			255			320			380		
d_1 (nominal dimension seal)		80	90	100	100	110	125	125	140	160	160	180	200	200	225	250	250	280	300
d_2		150			180			230			275			340			440		
d_3		22 for M16			26 for M20			30 for M24			40 for M30			46 for M36			55 for M42		
d_4 ³⁾		10,4			10,4			10,4			15,5			15,5			20,6		
d_5 ⁴⁾		G 3/8			G 3/8			G 3/8			G 1/2			G 3/4			G 3/4		
d_6 ⁴⁾		G 1 1/4			G 1 1/4			G 1 1/2			G 1 1/2			G 2			G 2 1/2		
e_1		300			375			450			560			670			800		
e_2		90			100			125			150			200			250		
h_1	$\begin{matrix} 0 \\ -0,5 \end{matrix}$	190			225			265			315			375			450		
h_2		325			380			460			565			680			830		
h_3		35			50			60			70			80			90		
l_1		355			450			540			660			800			950		
l_2		215			280			340			440			540			650		
l_3		28			30			40			50			60			85		
ϕk ⁵⁾ (spherical)	h6	190			212			280			335			425			530		

- 1) Applies only to circular cylindrical bores.
- 2) For the design with thrust bearing part (A), dimensions B may slightly deviate in order to obtain (depending on the type of tilting pad) a constant dimension b_1 (interchangeability of the half-bearing shell).
- 3) Rough bore for pinned fitting.
- 4) If larger connections are necessary, this shall be the subject of a special agreement.
- 5) The fit of the half-bearing and housing shall be a transition fit or shall be subject to agreement.