

**SLOVENSKI STANDARD  
SIST ISO 11687-3:2002**

**01-marec-2002**

---

8 fgb]`YÿUJ]!`Dc\_cb b]`YÿUJ]!" "XY.`Df]fcVb] b]`YÿUJ]`g`gfYX]ý bc`df]fcVb]Wt

Plain bearings -- Pedestal plain bearings -- Part 3: Centre flange bearings

Paliers lisses -- Paliers lisses à chaise sur le sol -- Partie 3: Paliers à bride centrale

**Ta slovenski standard je istoveten z: ISO 11687-3:1995**

[SIST ISO 11687-3:2002](https://standards.iteh.ai/catalog/standards/sist/e8e60a85-8d17-49b7-89dd-688c4caf0eec/sist-iso-11687-3-2002)

<https://standards.iteh.ai/catalog/standards/sist/e8e60a85-8d17-49b7-89dd-688c4caf0eec/sist-iso-11687-3-2002>

**ICS:**

21.100.10      Drsni ležaji                      Plain bearings

**SIST ISO 11687-3:2002**

**en**

**iTeh STANDARD PREVIEW**  
**(standards.iteh.ai)**

SIST ISO 11687-3:2002

<https://standards.iteh.ai/catalog/standards/sist/e8e60a85-8d17-49b7-89dd-688c4caf0eec/sist-iso-11687-3-2002>

INTERNATIONAL  
STANDARD

**ISO**  
**11687-3**

First edition  
1995-02-01

---

---

**Plain bearings — Pedestal plain  
bearings —**

**Part 3:**  
Centre flange bearings  
(standards.iteh.ai)

*Paliers lisses — Paliers lisses à chaise sur le sol —*  
*Partie 3: Paliers à bride centrale*  
<https://standards.iteh.ai/catalog/standards/sist/8c608518d17-49b7-89dd-688c4caf0ecc/sist-iso-11687-3-2002>



Reference number  
ISO 11687-3:1995(E)

**ISO 11687-3:1995(E)****Foreword**

ISO (the International Organization for Standardization) is a worldwide federation of national standards bodies (ISO member bodies). The work of preparing International Standards is normally carried out through ISO technical committees. Each member body interested in a subject for which a technical committee has been established has the right to be represented on that committee. International organizations, governmental and non-governmental, in liaison with ISO, also take part in the work. ISO collaborates closely with the International Electrotechnical Commission (IEC) on all matters of electrotechnical standardization.

Draft International Standards adopted by the technical committees are circulated to the member bodies for voting. Publication as an International Standard requires approval by at least 75 % of the member bodies casting a vote.

International Standard ISO 11687-3 was prepared by Technical Committee ISO/TC 123, *Plain bearings*, Subcommittee SC 3, *Dimensions, tolerances and construction details*.

ISO 11687 consists of the following parts, under the general title *Plain bearings* — *Pedestal plain bearings*:

- Part 1: *Pillow blocks*
- Part 2: *Side flange bearings*
- Part 3: *Centre flange bearings*

© ISO 1995

All rights reserved. Unless otherwise specified, no part of this publication may be reproduced or utilized in any form or by any means, electronic or mechanical, including photocopying and microfilm, without permission in writing from the publisher.

International Organization for Standardization  
Case Postale 56 • CH-1211 Genève 20 • Switzerland

Printed in Switzerland

# Plain bearings — Pedestal plain bearings —

## Part 3: Centre flange bearings

### 1 Scope

This part of ISO 11687 specifies design characteristics for centre flange bearings for the size range 9 to 28, as well as design characteristics for shafts.

It is applicable to centre flange bearings used mainly in electrical and turbo engineering industries.

ISO 630:1980, *Structural steels*.

ISO 683-11:1987, *Heat-treatable steels, alloy steels and free-cutting steels — Part 11: Wrought case-hardening steels*.

ISO 1302:1992, *Technical drawings — Method of indicating surface texture*.

### 2 Normative references

The following standards contain provisions which, through reference in this text, constitute provisions of this part of ISO 11687. At the time of publication, the editions indicated were valid. All standards are subject to revision, and parties to agreements based on this part of ISO 11687 are encouraged to investigate the possibility of applying the most recent editions of the standards indicated below. Members of IEC and ISO maintain registers of currently valid International Standards.

ISO 185:1988, *Grey cast iron — Classification*.

ISO 426-1:1983, *Wrought copper-zinc alloys — Chemical composition and forms of wrought products — Part 1: Non-leaded and special copper-zinc alloys*.

ISO 426-2:1983, *Wrought copper-zinc alloys — Chemical composition and forms of wrought products — Part 2: Leaded copper-zinc alloys*.

ISO 2768-1:1989, *General tolerances — Part 1: Tolerances for linear and angular dimensions without individual tolerance indications*.

ISO 2768-2:1989, *General tolerances — Part 2: Geometrical tolerances for features without individual tolerance indications*.

ISO 3755:1991, *Cast carbon steels for general engineering purposes*.

ISO 4381:1991, *Plain bearings — Lead and tin casting alloys for multilayer plain bearings*.

ISO 8062:1994, *Castings — System of dimensional tolerances and machining allowances*.

ISO 12129-1:—<sup>1)</sup>, *Plain bearings — Part 1: Fits*.

ISO 12129-2:—<sup>1)</sup>, *Plain bearings — Part 2: Tolerances on form and position and surface roughness for shafts, flanges and thrust collars*.

1) To be published.

### 3 Types of bearing

According to their design, centre flange bearings can be devised as follows, each characteristic being designated by a letter symbol.

#### Housing:

M Centre flange bearing with cooling fins

#### Heat dissipation:

N Natural cooling  
 W Water cooling in oil sump  
 U Circulation pump and natural cooling  
 T Circulation pump and water cooling in oil sump  
 Z Recirculating oil lubrication with external cooling of oil

#### Shape of bore for journal bearing and type of lubrication:

C Circular cylindrical bore without oil ring  
 L Circular cylindrical bore with split oil ring not fixed on a rotating shaft  
 Y Lobed bearing with two sliding surfaces without oil ring  
 V Lobed bearing with four sliding surfaces without oil ring

#### Thrust bearing:

Q Without sliding surfaces [non-locating (free) bearing]  
 B Plain sliding surfaces with oil grooves (guide bearing)  
 K Wedge surfaces  
 A Tilting pads

(design and dimensions at the manufacturer's discretion)

#### Seal:

Type and dimensions subject to agreement

The symbols above figure 1 explain only the type illustrated; the complete type required shall be specified in the above-mentioned sequence when ordering.

### 4 Dimensions

See figures 1 to 3 and tables 1 and 2.

The centre flange bearings are not expected to conform to the design illustrated in figure 1; compliance is only required with respect to the dimensions specified.

NOTE 1 All dimensions are given in millimetres.

Details which are not specified shall be chosen as appropriate.

### 5 Shaft design

See figures 2 and 3 and table 2.

### 6 Materials

#### Housing:

Grade 300 in accordance with ISO 185; other materials subject to agreement

#### Half-bearing:

Bearing back:

Fe 360 B in accordance

with ISO 630-49b7-89dd-

C10 or C15 E 4 in accordance with ISO 683-11

200 to 400 in accordance with ISO 3755

Type of material at the manufacturer's discretion

#### Bearing metal:

Lead-tin-alloy in accordance with ISO 4381, or subject to agreement

#### Seal:

Copper alloy, aluminium alloy or plastic, subject to agreement

#### Oil ring, not fixed on rotating shaft:

Copper-zinc alloy in accordance with ISO 426, or subject to agreement

## 7 Design

### General tolerances:

For machined surfaces:

ISO 2768-1 and ISO 2768-2 - mH

For unmachined surfaces:

ISO 8062 - CT 9 (for grade 300), or corresponding standards for other materials agreed upon.

### Surface roughness in accordance with ISO 1302:

Flange bearing:

Mounted surfaces:  $R_a = 3,2 \mu\text{m}$   
Sliding surfaces:  $R_a = 0,8 \mu\text{m}$

Shaft: See table 2, footnote 1.

### Housing:

Flange bearing housing with lifting eye bolts or means of conveyance at the manufacturer's discretion.

The inner surfaces of the housing shall be clean and shall have a coat of paint resistant to oil and solvents.

The outer surfaces of the housing shall be protected against corrosion.

For the purpose of pressure compensation, the individual oil spaces within the flange bearing housing shall be connected to each other by means of appropriate openings above the oil level.

All bearing housing connections on both sides; other connecting dimensions and arrangements than those given in figure 1 as well as additional connections subject to agreement.

Type of inspection plate at the manufacturer's discretion.

With bolts and screws for housing parts and seals, at the manufacturer's discretion.

Bolts and screws for the housing flange do not form part of the delivery.

### General:

Particular agreements shall be made for applications under special conditions (e.g. inclined positions).

Chamfered edges: type of edge chamfering at the manufacturer's discretion.

If the bearing is only applicable to one direction of rotation, a directional arrow shall be provided.

## 8 Designation

### EXAMPLE

Designation of a centre flange bearing of size 14, shaft diameter 125 mm, housing with cooling fins (M), for recirculating oil lubrication with external cooling of oil (Z), circular cylindrical bore with split oil ring not fixed on a rotating shaft for emergency run (L) and thrust bearing with wedge surfaces (K):

**Centre flange bearing ISO 11687-3 - 14 - 125 - MZLK**

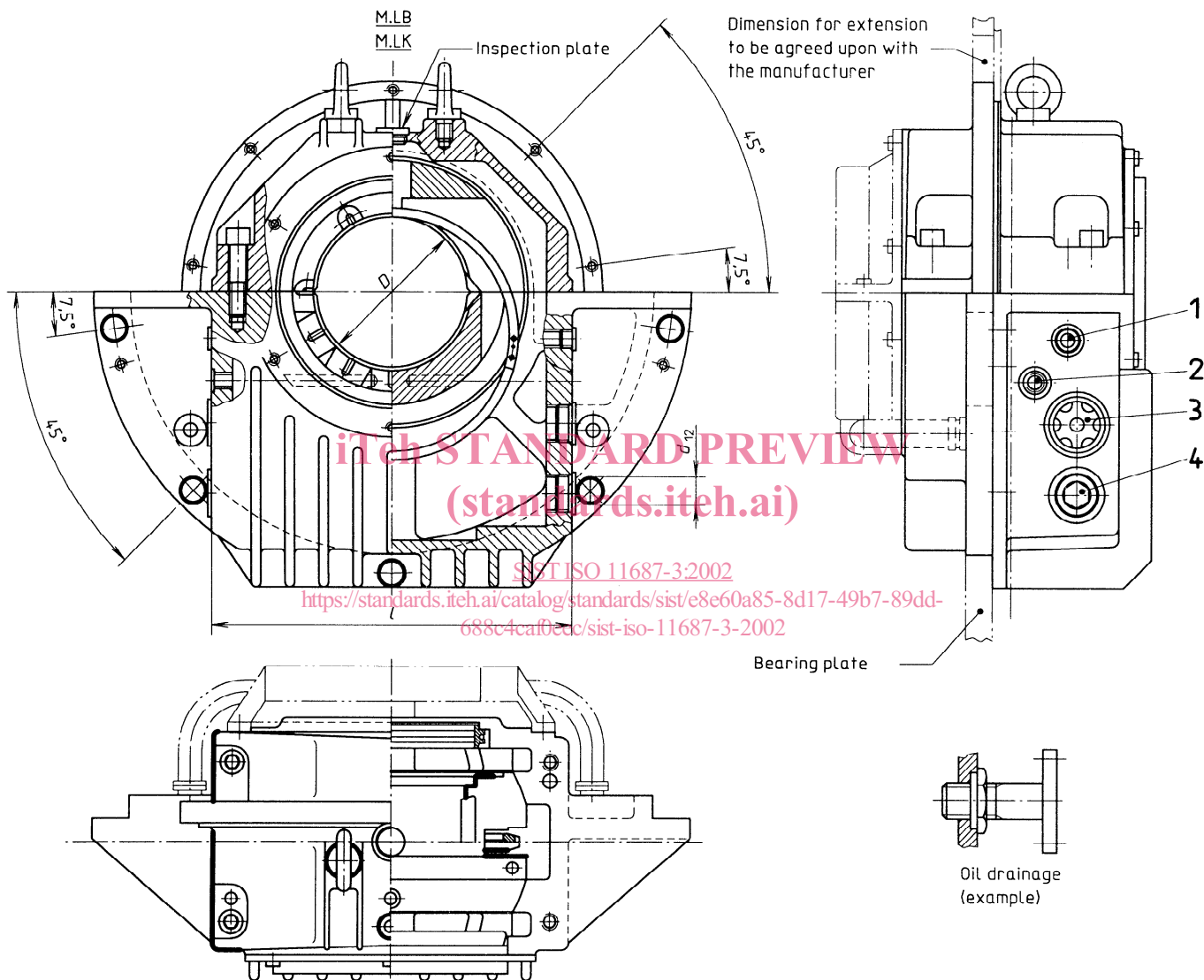

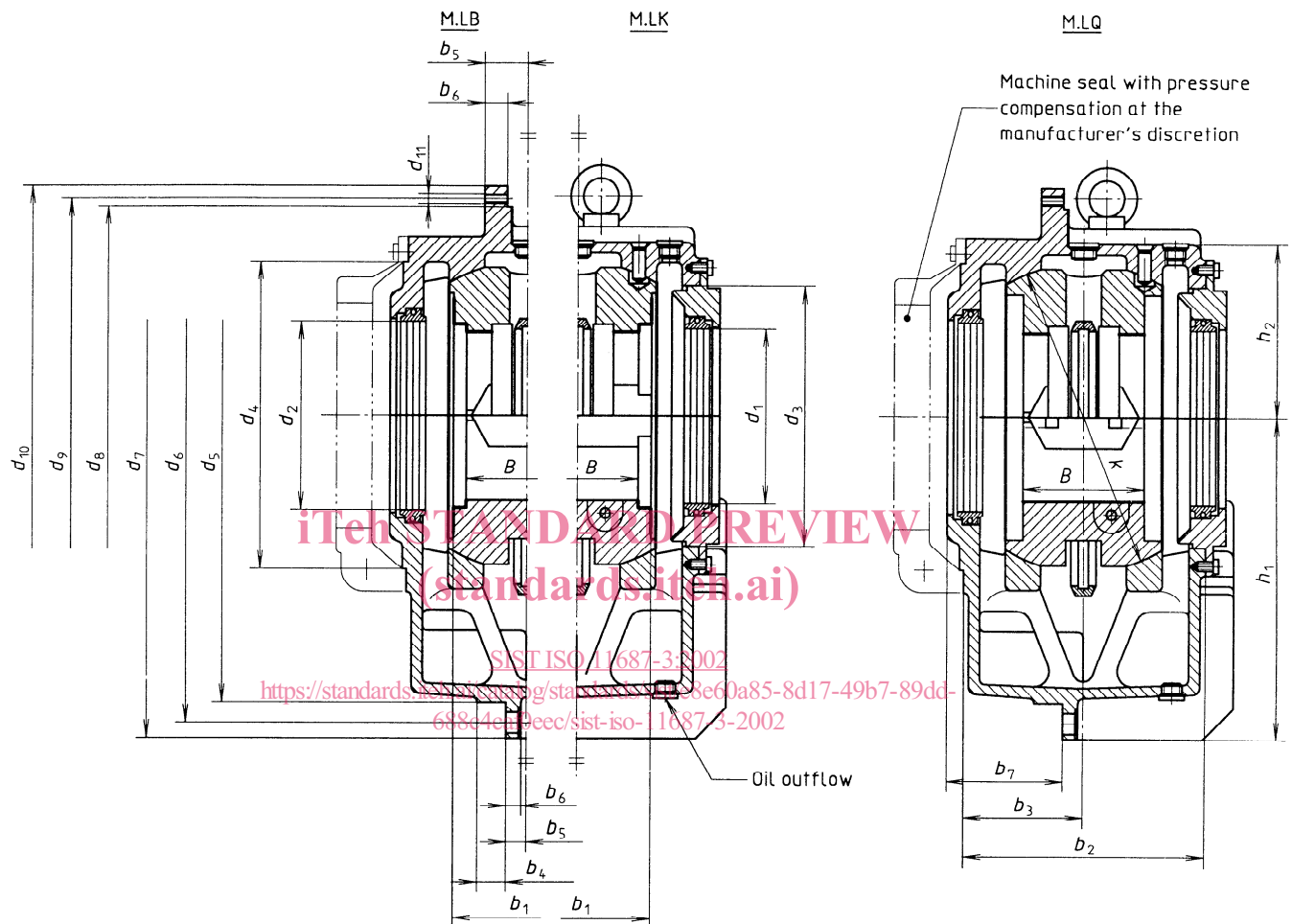

**Key**

- 1  $d_{13}$  Oil inlet (recirculating plant, circulation pump)
- 2 Thread G 1/2 Connection for thermoprobe
- 3  $d_{14}$  Oil-level indicator or oil drainage for recirculating plant
- 4 Screw plug (connection for radiator, oil-sump thermometer, suction line of circulation pump, finned cooler)

**Figure 1 — Examples of centre flange bearings — Size range 9 to 28**