



SLOVENSKI STANDARD

SIST EN 302 307 V1.1.1:2006

01-marec-2006

Digitalna videoradiodifuzija (DVB) – Druga generacija strukture okvirov, kodiranja kanalov in modulacijskih sistemov za radiodifuzijo, interaktivne storitve, novinarstvo in druge širokopasovne satelitske aplikacije

Digital Video Broadcasting (DVB); Second generation framing structure, channel coding and modulation systems for Broadcasting, Interactive Services, News Gathering and other broadband satellite applications

STANDARD PREVIEW
(standards.iteh.ai)

[SIST EN 302 307 V1.1.1:2006](https://standards.iteh.ai/catalog/standards/sist/4bc0d536-684a-4299-ad4f-26b3c7201d22/sist-en-302-307-v1-1-1-2006)

<https://standards.iteh.ai/catalog/standards/sist/4bc0d536-684a-4299-ad4f-26b3c7201d22/sist-en-302-307-v1-1-1-2006>

Ta slovenski standard je istoveten z: EN 302 307 Version 1.1.1

ICS:

33.170

Televizijska in radijska
difuzija

Television and radio
broadcasting

SIST EN 302 307 V1.1.1:2006

en

iTeh STANDARD PREVIEW
(standards.iteh.ai)

SIST EN 302 307 V1.1.1:2006

<https://standards.iteh.ai/catalog/standards/sist/4bc0d536-684a-4299-ad4f-26b3c7201d22/sist-en-302-307-v1-1-1-2006>

ETSI EN 302 307 V1.1.1 (2005-03)

European Standard (Telecommunications series)

**Digital Video Broadcasting (DVB);
Second generation framing structure, channel coding and
modulation systems for Broadcasting, Interactive Services,
News Gathering and other broadband satellite applications**

**iTeh STANDARD PREVIEW
(standards.iteh.ai)**

[SIST EN 302 307 V1.1.1:2006](https://standards.iteh.ai/catalog/standards/sist/4bc0d536-684a-4299-ad4f-26b3c7201d22/sist-en-302-307-v1-1-1-2006)

<https://standards.iteh.ai/catalog/standards/sist/4bc0d536-684a-4299-ad4f-26b3c7201d22/sist-en-302-307-v1-1-1-2006>



Reference

DEN/JTC-DVB-154

Keywords

BSS, modulation**ETSI**

650 Route des Lucioles
F-06921 Sophia Antipolis Cedex - FRANCE

Tel.: +33 4 92 94 42 00 Fax: +33 4 93 65 47 16

Siret N° 348 623 562 00017 - NAF 742 C
Association à but non lucratif enregistrée à la
Sous-Préfecture de Grasse (06) N° 7803/88

iTeh STANDARD PREVIEW
(standards.iteh.ai)

SIST EN 302 307 V1.1.1:2006

<https://standards.iteh.ai/catalog/standards/sist/4bc0d536-684a-4299-ad4f-26b3c7201d72/sist-en-302-307-v1-1-1-2006>

Important notice

Individual copies of the present document can be downloaded from:

<http://www.etsi.org>

The present document may be made available in more than one electronic version or in print. In any case of existing or perceived difference in contents between such versions, the reference version is the Portable Document Format (PDF). In case of dispute, the reference shall be the printing on ETSI printers of the PDF version kept on a specific network drive within ETSI Secretariat.

Users of the present document should be aware that the document may be subject to revision or change of status. Information on the current status of this and other ETSI documents is available at

<http://portal.etsi.org/tb/status/status.asp>

If you find errors in the present document, please send your comment to one of the following services:

http://portal.etsi.org/chaicor/ETSI_support.asp

Copyright Notification

No part may be reproduced except as authorized by written permission.
The copyright and the foregoing restriction extend to reproduction in all media.

© European Telecommunications Standards Institute 2005.
All rights reserved.

DECT™, **PLUGTESTS™** and **UMTS™** are Trade Marks of ETSI registered for the benefit of its Members.
TIPHON™ and the **TIPHON logo** are Trade Marks currently being registered by ETSI for the benefit of its Members.
3GPP™ is a Trade Mark of ETSI registered for the benefit of its Members and of the 3GPP Organizational Partners.

Contents

Intellectual Property Rights	5
Foreword.....	5
1 Scope	6
2 References	8
3 Symbols and abbreviations.....	9
3.1 Symbols.....	9
3.2 Abbreviations	10
4 Transmission system description.....	11
4.1 System definition.....	11
4.2 System architecture	12
4.3 System configurations	13
5 Subsystems specification.....	14
5.1 Mode adaptation.....	14
5.1.1 Input interface.....	14
5.1.2 Input stream synchronizer (optional, not relevant for single TS - BS)	15
5.1.3 Null-Packet Deletion (ACM and Transport Stream only)	15
5.1.4 CRC-8 encoder (for packetized streams only).....	15
5.1.5 Merger/Slicer	16
5.1.6 Base-Band Header insertion.....	17
5.2 Stream adaptation.....	18
5.2.1 Padding.....	19
5.2.2 BB scrambling	19
5.3 FEC encoding.....	19
5.3.1 Outer encoding (BCH).....	20
5.3.2 Inner encoding (LDPC).....	21
5.3.2.1 Inner coding for normal FECFRAME.....	22
5.3.2.2 Inner coding for short FECFRAME.....	23
5.3.3 Bit Interleaver (for 8PSK, 16APSK and 32APSK only).....	23
5.4 Bit mapping into constellation.....	25
5.4.1 Bit mapping into QPSK constellation.....	25
5.4.2 Bit mapping into 8PSK constellation.....	25
5.4.3 Bit mapping into 16APSK constellation.....	26
5.4.4 Bit mapping into 32APSK	27
5.5 Physical Layer (PL) framing	27
5.5.1 Dummy PLFRAME insertion.....	28
5.5.2 PL signalling.....	28
5.5.2.1 SOF field.....	29
5.5.2.2 MODCOD field.....	29
5.5.2.3 TYPE field	29
5.5.2.4 PLS code	29
5.5.3 Pilots insertion	30
5.5.4 Physical layer scrambling	30
5.6 Baseband shaping and quadrature modulation	32
6 Error performance	33
Annex A (normative): Signal spectrum at the modulator output.....	34
Annex B (normative): Addresses of parity bit accumulators for $n_{ldpc} = 64\ 800$.....	36
Annex C (normative): Addresses of parity bit accumulators for $n_{ldpc} = 16\ 200$.....	45
Annex D (normative): Additional Mode Adaptation and ACM tools	48

D.1	"ACM Command" signalling interface	48
D.2	Input stream synchronizer	48
D.3	Null-packet Deletion (normative for input transport streams and ACM).....	50
D.4	BBHEADER and Merging/slicing Policy for various application areas.....	51
D.5	Signalling of reception quality via return channel (Normative for ACM).....	52
Annex E (normative):	SI and signal identification for DSNG and contribution applications	54
Annex F (normative):	Backwards Compatible modes (optional).....	55
Annex G (informative):	Supplementary information on receiver implementation	58
G.1	Carrier recovery.....	58
G.2	FEC decoding.....	58
G.3	ACM: Transport Stream regeneration and clock recovery using ISCR	61
G.4	Non linearity pre-compensation and Intersymbol Interference suppression techniques	61
G.5	Interactive services using DVB-RCS return link: user terminal synchronization.....	62
Annex H (informative):	Examples of possible use of the System.....	63
H.1	CCM digital TV broadcasting: bit rate capacity and C/N requirements	63
H.2	Distribution of multiple TS multiplexes to DTT Transmitters (Multiple TS, CCM).....	65
H.3	SDTV and HDTV broadcasting with differentiated protection (VCM, Multiple TS)	66
H.4	DSNG Services using ACM (Single transport Stream, information rate varying in time)	66
H.5	IP Unicast Services (Non-uniform protection on a user-by-user basis)	67
H.6	Example performance of BC modes.....	69
H.7	Satellite transponder models for simulations	70
H.8	Phase noise masks for simulations	72
Annex I (informative):	Bibliography.....	73
History	74

Intellectual Property Rights

IPRs essential or potentially essential to the present document may have been declared to ETSI. The information pertaining to these essential IPRs, if any, is publicly available for **ETSI members and non-members**, and can be found in ETSI SR 000 314: "*Intellectual Property Rights (IPRs); Essential, or potentially Essential, IPRs notified to ETSI in respect of ETSI standards*", which is available from the ETSI Secretariat. Latest updates are available on the ETSI Web server (<http://webapp.etsi.org/IPR/home.asp>).

Pursuant to the ETSI IPR Policy, no investigation, including IPR searches, has been carried out by ETSI. No guarantee can be given as to the existence of other IPRs not referenced in ETSI SR 000 314 (or the updates on the ETSI Web server) which are, or may be, or may become, essential to the present document.

Foreword

This European Standard (Telecommunications series) has been produced by Joint Technical Committee (JTC) Broadcast of the European Broadcasting Union (EBU), Comité Européen de Normalisation ELECtrotechnique (CENELEC) and the European Telecommunications Standards Institute (ETSI).

The work of the JTC was based on the studies carried out by the European DVB Project under the auspices of the Ad Hoc Group on DVB-S.2 of the DVB Technical Module. This joint group of industry, operators and broadcasters provided the necessary information on all relevant technical matters (see bibliography).

NOTE: The EBU/ETSI JTC Broadcast was established in 1990 to co-ordinate the drafting of standards in the specific field of broadcasting and related fields. Since 1995 the JTC Broadcast became a tripartite body by including in the Memorandum of Understanding also CENELEC, which is responsible for the standardization of radio and television receivers. The EBU is a professional association of broadcasting organizations whose work includes the co-ordination of its members' activities in the technical, legal, programme-making and programme-exchange domains. The EBU has active members in about 60 countries in the European broadcasting area; its headquarters is in Geneva.

European Broadcasting Union
 CH-1218 GRAND SACONNEX (Geneva)
 Switzerland
 Tel: +41 22 717 21 11
 Fax: +41 22 717 24 81

Founded in September 1993, the DVB Project is a market-led consortium of public and private sector organizations in the television industry. Its aim is to establish the framework for the introduction of MPEG-2 based digital television services. Now comprising over 200 organizations from more than 25 countries around the world, DVB fosters market-led systems, which meet the real needs, and economic circumstances, of the consumer electronics and the broadcast industry.

National transposition dates

Date of adoption of this EN:	18 March 2005
Date of latest announcement of this EN (doa):	30 June 2005
Date of latest publication of new National Standard or endorsement of this EN (dop/e):	31 December 2005
Date of withdrawal of any conflicting National Standard (dow):	31 December 2005

1 Scope

DVB-S (EN 300 421 [2]) was introduced as a standard in 1994 and DVB-DSNG (EN 301 210 [3]) in 1997. The DVB-S standard specifies QPSK modulation and concatenated convolutional and Reed-Solomon channel coding, and is now used by most satellite operators worldwide for television and data broadcasting services. DVB-DSNG specifies, in addition to DVB-S format, the use of 8PSK and 16QAM modulation for satellite news gathering and contribution services.

Since 1997, digital satellite transmission technology has evolved somewhat:

- New channel coding schemes, combined with higher order modulation, promise more powerful alternatives to the DVB-S/DVB-DSNG coding and modulation schemes. The result is a capacity gain in the order of 30 % at a given transponder bandwidth and transmitted EIRP, depending on the modulation type and code rate.
- Variable Coding and Modulation (VCM) may be applied to provide different levels of error protection to different service components (e.g. SDTV and HDTV, audio, multimedia).
- In the case of interactive and point-to-point applications, the VCM functionality may be combined with the use of return channels, to achieve Adaptive Coding and Modulation (ACM). This technique provides more exact channel protection and dynamic link adaptation to propagation conditions, targeting each individual receiving terminal. ACM systems promise satellite capacity gains of up to 100 %-200 %. In addition, service availability may be extended compared to a constant protection system (CCM) such as DVB-S or DVB-DSNG. Such gains are achieved by informing the satellite up-link station of the channel condition (e.g. C/N+I) of each receiving terminal via the satellite or terrestrial return channels.
- DVB-S and DVB-DSNG are strictly focused on a unique data format, the MPEG Transport Stream (ISO/IEC 13818-1 [1] or a reference to it). Extended flexibility to cope with other input data formats (such as multiple Transport Streams, or generic data formats) is now possible without significant complexity increase.

The present document defines a "second generation" modulation and channel coding system (denoted the "System" or "DVB-S.2" for the purposes of the present document) to make use of the improvements listed above. DVB-S.2 is a single, very flexible standard, covering a variety of applications by satellite, as described below. It is characterized by:

- A flexible input stream adapter, suitable for operation with single and multiple input streams of various formats (packetized or continuous);
- a powerful FEC system based on LDPC (Low-Density Parity Check) codes concatenated with BCH codes, allowing Quasi-Error-Free operation at about 0,7dB to 1 dB from the Shannon limit, depending on the transmission mode (AWGN channel, modulation constrained Shannon limit);
- a wide range of code rates (from 1/4 up to 9/10); 4 constellations, ranging in spectrum efficiency from 2 bit/s/Hz to 5 bit/s/Hz, optimized for operation over non-linear transponders;
- a set of three spectrum shapes with roll-off factors 0,35, 0,25 and 0,20;
- Adaptive Coding and Modulation (ACM) functionality, optimizing channel coding and modulation on a frame-by-frame basis.

The System has been optimized for the following **broadband satellite applications**:

Broadcast Services (BS) Digital multi-programme Television (TV)/High Definition Television (HDTV)

Broadcasting services to be used for primary and secondary distribution in the Fixed Satellite Service (FSS) and the Broadcast Satellite Service (BSS) bands.

DVB-S.2 is intended to provide Direct-To-Home (DTH) services for consumer Integrated Receiver Decoder (IRD), as well as collective antenna systems (Satellite Master Antenna Television - SMATV) and cable television head-end stations (possibly with remodulation, see EN 300 429 [6]). DVB-S.2 may be considered a successor to the current DVB-S standard EN 300 421 [2], and may be introduced for new services and allow for a long-term migration. BS services are transported in MPEG Transport Stream format. VCM may be applied on multiple transport stream to achieve a differentiated error protection for different services (TV, HDTV, audio, multimedia). Two modes are available:

- **NBC-BS** (Non Backwards Compatible Broadcast Services) is not backwards-compatible with EN 300 421 [2].
- **BC-BS** (Backwards-Compatible Broadcast Services) is backwards-compatible to EN 300 421 [2] (see annex F).

In fact, with a large number of DVB-S receivers already installed, backwards compatibility may be required for a period of time, where old receivers continue to receive the same capacity as before, while the new DVB-S.2 receivers could receive additional capacity broadcasts. When the complete receiver population has migrated to DVB-S.2, the transmitted signal can be modified to a non-backward compatible mode, thus exploiting the full potential of DVB-S.2. To facilitate the reception of DVB-S services by DVB-S.2 receivers, implementation of DVB-S in DVB-S.2 chips is highly recommended.

Interactive Services (IS) Interactive data services including Internet access

DVB-S.2 is intended to provide interactive services to consumer IRDs and to personal computers, where DVB-S.2's forward path supersedes the current DVB-S standard EN 300 421 [2] for interactive systems. The return path can be implemented using various DVB interactive systems, such as DVB-RCS (EN 301 790 [7]), DVB-RCP (ETS 300 801 [8]), DVB-RCG (EN 301 195 [9]), DVB-RCC (ES 200 800 [10]). Data services are transported in (single or multiple) Transport Stream format according to EN 301 192 [5] (e.g. using Multiprotocol Encapsulation), or in (single or multiple) generic stream format. DVB-S.2 can provide Constant Coding and Modulation (CCM), or Adaptive Coding and Modulation (ACM), where each individual satellite receiving station controls the protection mode of the traffic addressed to it. Input Stream Adaptation for ACM is specified in annex D.

Digital TV Contribution and Satellite News Gathering (DTVC/DSNG)

Digital television contribution applications by satellite consist of point-to-point or point-to-multipoint transmissions, connecting fixed or transportable uplink and receiving stations. They are not intended for reception by the general public. According to ITU-R Recommendation SNG.770-1 [11], SNG is defined as "Temporary and occasional transmission with short notice of television or sound for broadcasting purposes, using highly portable or transportable uplink earth stations ...". Services are transported in single (or multiple) MPEG Transport Stream format. DVB-S.2 can provide Constant Coding and Modulation (CCM), or Adaptive Coding and Modulation (ACM). In this latter case, a single satellite receiving station typically controls the protection mode of the full multiplex. Input Stream Adaptation for ACM is specified in annex D.

Data content distribution/trunking and other professional applications (PS)

These services are mainly point-to-point or point-to-multipoint, including interactive services to professional head-ends, which re-distribute services over other media. Services may be transported in (single or multiple) generic stream format. The system can provide Constant Coding and Modulation (CCM), Variable Coding and Modulation (VCM) or Adaptive Coding and Modulation (ACM). In this latter case, a single satellite receiving station typically controls the protection mode of the full TDM multiplex, or multiple receiving stations control the protection mode of the traffic addressed to each one. In either case, interactive or non-interactive, the present document is only concerned with the forward broadband channel.

DVB-S.2 is suitable for use on different satellite transponder bandwidths and frequency bands. The symbol rate is matched to given transponder characteristics, and, in the case of multiple carriers per transponder (FDM), to the frequency plan adopted. Examples of possible DVB-S.2 use are given in clause H.1.

Digital transmissions via satellite are affected by power and bandwidth limitations. Therefore DVB-S.2 provides for many transmission modes (FEC coding and modulations), giving different trade-offs between power and spectrum efficiency (see annex H.1). For some specific applications (e.g. broadcasting) modes such as QPSK and 8PSK, with their quasi-constant envelope, are appropriate for operation with saturated satellite power amplifiers (in single carrier per transponder configuration). When higher power margins are available, spectrum efficiency can be further increased to reduce bit delivery cost. In these cases also 16APSK and 32APSK can operate in single carrier mode close to the satellite HPA saturation by pre-distortion techniques. All the modes are appropriate for operation in quasi-linear satellite channels, in multi-carrier Frequency Division Multiplex (FDM) type applications.

DVB-S.2 is compatible with Moving Pictures Experts Group (MPEG-2 and MPEG-4) coded TV services (see ISO/IEC 13818-1 [1]), with a Transport Stream packet multiplex. Multiplex flexibility allows the use of the transmission capacity for a variety of TV service configurations, including sound and data services. All service components are Time Division Multiplexed (TDM) on a single digital carrier.

The present document:

- gives a general description of the DVB-S.2 system;
- specifies the digitally modulated signal in order to allow compatibility between pieces of equipment developed by different manufacturers. This is achieved by describing in detail the signal processing principles at the modulator side, while the processing at the receive side is left open to different implementation solutions. However, it is necessary in the present document to refer to certain aspects of reception;
- identifies the global performance requirements and features of the System, in order to meet the service quality targets.

2 References

The following documents contain provisions which, through reference in this text, constitute provisions of the present document.

- References are either specific (identified by date of publication and/or edition number or version number) or non-specific.
- For a specific reference, subsequent revisions do not apply.
- For a non-specific reference, the latest version applies.

Referenced documents which are not found to be publicly available in the expected location might be found at <http://docbox.etsi.org/Reference>.

- SIST EN 302 307 V1.1.1:2006
Information technology - Generic coding of moving pictures and associated audio information
- iTech STANDARD PREVIEW
(standards.iteh.ai)
- [1] ISO/IEC 13818 (parts 1 and 2): "Information technology - Generic coding of moving pictures and associated audio information"
 - [2] ETSI EN 300 421 (V.1.1.2): "Digital Video Broadcasting (DVB); Framing structure, channel coding and modulation for 11/12 GHz satellite services".
 - [3] ETSI EN 301 210: "Digital Video Broadcasting (DVB); Framing structure, channel coding and modulation for Digital Satellite News Gathering (DSNG) and other contribution applications by satellite".
 - [4] ETSI TR 101 154: "Digital Video Broadcasting (DVB); Implementation guidelines for the use of MPEG-2 Systems, Video and Audio in satellite, cable and terrestrial broadcasting applications".
 - [5] ETSI EN 301 192: "Digital Video Broadcasting (DVB); DVB specification for data broadcasting".
 - [6] ETSI EN 300 429: "Digital Video Broadcasting (DVB); Framing structure, channel coding and modulation for cable systems".
 - [7] ETSI EN 301 790: "Digital Video Broadcasting (DVB); Interaction channel for satellite distribution systems".
 - [8] ETSI ETS 300 801: "Digital Video Broadcasting (DVB); Interaction channel through Public Switched Telecommunications Network (PSTN)/ Integrated Services Digital Networks (ISDN)".
 - [9] ETSI EN 301 195: "Digital Video Broadcasting (DVB); Interaction channel through the Global System for Mobile communications (GSM)".
 - [10] ETSI ES 200 800: "Digital Video Broadcasting (DVB); DVB interaction channel for Cable TV distribution systems (CATV)".
 - [11] ITU-R Recommendation SNG.770-1: "Uniform operational procedures for satellite news gathering (SNG)".

- [12] ETSI ETS 300 802: "Digital Video Broadcasting (DVB); Network-independent protocols for DVB interactive services".

3 Symbols and abbreviations

3.1 Symbols

For the purposes of the present document, the following symbols apply:

α	Roll-off factor
γ	Ratio between constellation radii for 16APSK and 32APSK
c	codeword
C/N	Carrier-to-noise power ratio (N measured in a bandwidth equal to symbol rate)
$C/N+I$	Carrier-to-(Noise+Interference) ratio
$d_{n_{bch}-k_{bch}-1}, d_{n_{bch}-k_{bch}-2}, \dots, d_1, d_0$	BCH code redundancy bits
$d(x)$	BCH code remainder of the division between the generator polynomial and $x^{n_{bch}-k_{bch}} m(x)$
DFL	Data Field Length
d_{min}	LDPC code minimum distance
E_b/N_0	Ratio between the energy per information bit and single sided noise power spectral density
E_s/N_0	Ratio between the energy per transmitted symbol and single sided noise power spectral density
f_N	Nyquist frequency
f_0	Carrier frequency
G	PLS code generator matrix
$g(x)$	code generator polynomial
$g_1(x), g_2(x), \dots, g_{12}(x)$	polynomials to obtain BCH code generator polynomial
i	LDPC code information block
$i_0, i_1, \dots, i_{k_{ldpc}-1}$	LDPC code information bits
$H(f)$	RC filters frequency transfer function
$H_{(n-k) \times n}$	LDPC code parity check matrix
I, Q	In-phase, Quadrature phase components of the modulated signal
K_{bch}	number of bits of BCH uncoded Block
N_{bch}	number of bits of BCH coded Block
k_{ldpc}	number of bits of LDPC uncoded Block
n_{ldpc}	number of bits of LDPC coded Block
η	PLFRAMING efficiency
η_c	code efficiency
η_{MOD}	number of transmitted bits per constellation symbol
η_{tot}	System spectral efficiency
m	BCH code information word
$m(x)$	BCH code message polynomial
$m_{k_{bch}-1}, m_{k_{bch}-2}, \dots, m_1, m_0$	BCH code information bits
M	number of modulated symbols in SLOT
$P_0, P_1, \dots, P_{n_{ldpc}-k_{ldpc}-1}$	LDPC code parity bits
P	number of pilot symbols in a pilot block
q	code rate dependant constant for LDPC codes
θ	deviation angle in hierarchical constellations
r_m	In-band ripple (dB)
R_s	Symbol rate corresponding to the bilateral Nyquist bandwidth of the modulated signal

R_u	Useful bit rate at the DVB-S.2 system input
S	Number of Slots in a XFECFRAME
T_s	Symbol period
UPL	User Packet Length

3.2 Abbreviations

For the purposes of the present document, the following abbreviations apply:

16APSK	16-ary Amplitude and Phase Shift Keying
32APSK	32-ary Amplitude and Phase Shift Keying
8PSK	8-ary Phase Shift Keying
ACM	Adaptive Coding and Modulation
ASI	Asynchronous Serial Interface
AWGN	Additive White Gaussian Noise
BB	BaseBand
BC	Backwards-Compatible

NOTE: Referred to the system allowing partial stream reception by DVB-S receivers.

BCH	Bose-Chaudhuri-Hocquenghem multiple error correction binary block code
BER	Bit Error Ratio
B_s	Bandwidth of the frequency Slot allocated to a service
BS	Broadcast Service
BSS	Broadcast Satellite Service
BW	BandWidth (at -3 dB) of the transponder
CBR	Constant Bit Rate
CCM	Constant Coding and Modulation
CNI	Carrier to Noise plus Interference ratio
CRC	Cyclic Redundancy Check
D	Decimal notation
DD	Decision Directed
DEMUX	DEMULTiplexer
DF	Data Field
DNP	Deleted Null Packets
DSNG	Digital Satellite News Gathering
DTH	Direct To Home
DTT	Digital Terrestrial Television
DVB	Digital Video Broadcasting project
DVB-S	DVB System for satellite broadcasting specified in EN 300 421 [2]
DVB-S.2	DVB-S.2 System as specified in the present document.
EBU	European Broadcasting Union
EN	European Norm
FDM	Frequency Division Multiplex
FEC	Forward Error Correction
FIFO	First In First Out
FSS	Fixed Satellite Service
GF	Galois Field
GS	Generic Stream
HDTV	High Definition TeleVision
HEX	HEXadecimal notation
HP	High Priority
IBO	Input Back Off
IF	Intermediate Frequency
IMUX	Input MULTiplexer - filter
IRD	Integrated Receiver Decoder
IS	Interactive Services
ISCR	Input Stream Time Reference
ISI	Input Stream Identifier
ISSY	Input Stream SYNchronizer

ISSYI	Input Stream SYnchronizer Indicator
ITU	International Telecommunications Union
LDPC	Low Density Parity Check (codes)
LNB	Low Noise Block
LP	Low Priority
LSB	Least Significant Bit
MIS	Multiple Input Stream
MPE	Multi-Protocol Encapsulation
MPEG	Moving Pictures Experts Group
MSB	Most Significant Bit

NOTE: In DVB-S.2 the MSB is always transmitted first.

NBC	Non-Backwards-Compatible
MUX	MULTipleX
NA	Not Applicable
OBO	Output Back Off
OCT	OCTal notation
OMUX	Output MULTipleXer - filter
NP	Null Packets
NPD	Null-Packet Deletion
PER	(MPEG TS) Packet Error Rate
PID	Packet IDentifier
PL	Physical Layer
PLL	Phase-Locked Loop
PLS	Physical Layer Signalling
PS	Professional Services
PSK	Phase Shift Keying
PRBS	Pseudo Random Binary Sequence
QEF	Quasi-Error-Free
QPSK	Quaternary Phase Shift Keying
RF	Radio Frequency
RO	Roll-Off
SDTV	Standard Definition TeleVision
SIS	Single Input Stream
SNG	Satellite News Gathering
SMATV	Satellite Master Antenna TeleVision
SOF	Start Of Frame
TDM	Time Division Multiplex
TS	Transport Stream
TV	TeleVision
TWTA	Travelling Wave Tube Amplifier
VCM	Variable Coding and Modulation

STANDARD PREVIEW
(standards.iteh.ai)

[SIST EN 302 307 V1.1.1:2006](https://standards.iteh.ai/catalog/standards/sist/4bc0d536-684a-4299-ad4f-26b5c7201d22/sist-en-302-307-v1-1-1-2006)

<https://standards.iteh.ai/catalog/standards/sist/4bc0d536-684a-4299-ad4f-26b5c7201d22/sist-en-302-307-v1-1-1-2006>

4 Transmission system description

4.1 System definition

The System is defined as the functional block of equipment performing the adaptation of the baseband digital signals, from the output of a single (or multiple) MPEG transport stream multiplexer(s) (ISO/IEC 13818-1 [1]), or from the output of a single (or multiple) generic data source(s), to the satellite channel characteristics. The System is designed to support source coding as defined in ISO/IEC 13818 [1], TR 101 154 [4] and TS 102 005 (see bibliography). Data services may be transported in Transport Stream format according to EN 301 192 [5] (e.g. using Multi-protocol Encapsulation), or Generic Stream format.

If the received signal is above the C/N+I threshold, the Forward Error Correction (FEC) technique adopted in the System is designed to provide a "Quasi Error Free" (QEF) quality target. The definition of QEF adopted for DVB-S.2 is "less than one uncorrected error-event per transmission hour at the level of a 5 Mbit/s single TV service decoder", approximately corresponding to a Transport Stream Packet Error Ratio $PER < 10^{-7}$ before de-multiplexer.

4.2 System architecture

According to figure 1, the DVB-S.2 System shall be composed of a sequence of functional blocks as described below.

Mode adaptation shall be application dependent. It shall provide input stream interfacing, Input Stream Synchronization (optional), null-packet deletion (for ACM and Transport Stream input format only), CRC-8 coding for error detection at packet level in the receiver (for packetized input streams only), merging of input streams (for Multiple Input Stream modes only) and slicing into DATA FIELDS. For Constant Coding and Modulation (CCM) and single input Transport Stream, Mode Adaptation shall consist of a "transparent" DVB-ASI (or DVB-parallel) to logical-bit conversion and CRC-8 coding. For Adaptive Coding and Modulation (ACM), Mode Adaptation shall be according to annex D.

A Base-Band Header shall be appended in front of the Data Field, to notify the receiver of the input stream format and Mode Adaptation type. To be noted that the MPEG multiplex transport packets may be asynchronously mapped to the Base-Band Frames.

Stream adaptation shall be applied, to provide padding to complete a Base-Band Frame and Base-Band Scrambling.

Forward Error Correction (FEC) Encoding shall be carried out by the concatenation of BCH outer codes and LDPC (Low Density Parity Check) inner codes (rates 1/4, 1/3, 2/5, 1/2, 3/5, 2/3, 3/4, 4/5, 5/6, 8/9, 9/10). Depending on the application area, the FEC coded block shall have length $n_{ldpc} = 64\ 800$ bits or 16 200 bits. When VCM and ACM is used, FEC and modulation mode may be changed in different frames, but remains constant within a frame. For Backwards Compatible modes, the bit-stream at the output of the FEC encoder shall be processed according to annex F. Bit interleaving shall be applied to FEC coded bits for 8PSK, 16APSK and 32APSK.

Mapping into QPSK, 8PSK, 16APSK and 32APSK constellations shall be applied, depending on the application area. Gray mapping of constellations shall be used for QPSK and 8PSK.

Physical layer framing shall be applied, synchronous with the FEC frames, to provide Dummy PLFRAME insertion, Physical Layer (PL) Signalling, pilot symbols insertion (optional) and Physical Layer Scrambling for energy dispersal. Dummy PLFRAMEs are transmitted when no useful data is ready to be sent on the channel. The System provides a regular physical layer framing structure, based on SLOTS of $M = 90$ modulated symbols, allowing reliable receiver synchronization on the FEC block structure. A slot is devoted to physical layer signalling, including Start-of-Frame delimitation and transmission mode definition. This mechanism is suitable also for VCM and ACM demodulator setting. Carrier recovery in the receivers may be facilitated by the introduction of a regular raster of pilot symbols ($P = 36$ pilot symbols every 16 SLOTS of 90 symbols), while a pilot-less transmission mode is also available, offering an additional 2,4 % useful capacity.

Base-Band Filtering and Quadrature Modulation shall be applied, to shape the signal spectrum (squared-root raised cosine, roll-off factors 0,35 or 0,25 or 0,20) and to generate the RF signal.

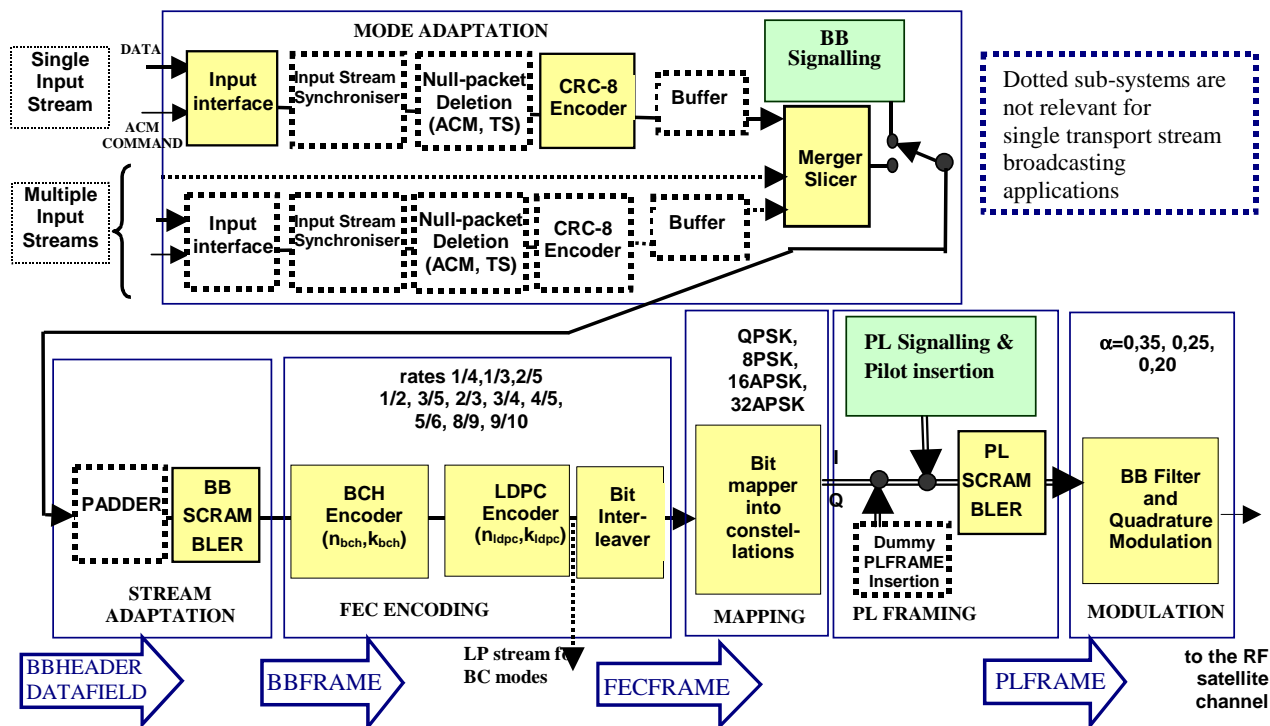

Figure 1: Functional block diagram of the DVB-S.2 System

iTeh STANDARD PREVIEW (standards.iteh.ai)

4.3 System configurations

Table 1 associates the System configurations to the applications areas. According to table 1, at least "Normative" subsystems and functionalities shall be implemented in the transmitting and receiving equipment to comply with the present document Guidelines for mode selection are given in annex H.

26b3c7201d22/sist-en-302-307-v1-1-1-2006