



Designation: D 6518 – 02

Standard Practice for Bias Testing a Mechanical Coal Sampling System¹

This standard is issued under the fixed designation D 6518; the number immediately following the designation indicates the year of original adoption or, in the case of revision, the year of last revision. A number in parentheses indicates the year of last reapproval. A superscript epsilon (ϵ) indicates an editorial change since the last revision or reapproval.

1. Scope

1.1 This practice presents sample collection and statistical evaluation procedures for testing mechanical sampling systems, subsystems, and individual system components for bias. It is the responsibility of the user of this practice to select the appropriate procedure for a specific sampling situation.

1.2 This practice does not purport to define an absolute bias. Bias defined by this practice is the difference between the population mean of the mechanical sampler test results and the accepted reference value.

1.3 *This standard does not purport to address all of the safety concerns, if any, associated with its use. It is the responsibility of the user of this standard to establish appropriate safety and health practices and determine the applicability of regulatory limitations prior to use.*

2. Referenced Documents

2.1 ASTM Standards:

- D 121 Terminology of Coal and Coke²
- D 2013 Method of Preparing Coal Samples for Analysis²
- D 2234 Practice for Collection of a Gross Sample of Coal²
- D 4621 Guide for Accountability and Quality Control in the Coal Analysis Laboratory²
- D 4702 Guide for Inspecting Crosscut, Sweep-Arm, and Auger Mechanical Coal Sampling Systems for Conformance with Current ASTM Standards²
- E 105 Practice for Probability Sampling of Materials³
- E 122 Practice for Choice of Sample Size to Estimate a Measure of Quality for a Lot or Process³
- E 456 Terminology Relating to Quality and Statistics³
- E 691 Practice for Conducting an Interlaboratory Study to Determine the Precision of a Test Method³

3. Terminology

3.1 *Definitions*—For additional definitions of terms used in this practice refer to Terminologies D 121 and E 456.

3.2 *Definitions of Terms Specific to This Standard:*

3.2.1 *bias, n*—the difference between the population mean

of the mechanical sampler test results and the accepted reference value.

3.2.2 *confidence interval, n*—a numeric interval with a lower limit and a higher limit within which the true parameter value is estimated to fall. The confidence interval percentage indicates the percentage of time the true value will fall within the interval if the procedure is continuously repeated.

3.2.3 *correlation, n*—a measure of the linear dependence between paired system and reference measurements. Correlation frequently is expressed by the correlation coefficient, which can take a value from minus one (perfect negative linear relationship) to plus one (perfect positive linear relationship).

3.2.4 *delimitation error, n*—a material error that occurs when all the elements in a cross section of a coal stream do not have an equal probability of being intercepted (captured) by the sampler cutter during increment collection.

3.2.5 *ellipsoidal region, n*—an area that is formed by plane sections of ellipses that are defined by the values selected for the largest tolerable bias of each coal characteristic used in the bias test. The region will be used to determine if the system is biased.

3.2.6 *Hotelling's T² test, n*—a statistical test that is used to evaluate multivariate data. It is the multivariate equivalent of the Student's *t*-test.

3.2.7 *largest tolerable bias (LTB), n*—an interval whose upper and lower bounds represent the limits of an acceptable bias.

3.2.8 *mechanical sampling system, n*—a single machine or series of interconnected machines whose purpose is to extract mechanically, or process (divide and reduce), or a combination thereof, a sample of coal.

3.2.9 *paired data set, n*—system and reference values observed on samples collected and compared from the same batch of material.

3.2.10 *reference sample, n*—a sample used in testing of a mechanical sampling system which is comprised of one or more increments collected from the test batch or lot of coal by the stopped belt method as described in Practice D 2234.

3.2.11 *reject stream, n*—the coal flow within a mechanical sampling system, which occurs at each stage of division, before and after reduction, and is not included in the system sample.

3.2.12 *save stream, n*—the coal flow within a mechanical sampling system which occurs at each stage of division, before and after reduction, and after the final stage of division

¹ This practice is under the jurisdiction of ASTM Committee D05 on Coal and Coke and is the direct responsibility of Subcommittee D05.23 on Sampling.

Current edition approved June 10, 2002. Published August 2002.

Originally published as D 6518-00. Last previous edition D 6518-01.

² *Annual Book of ASTM Standards*, Vol 05.06.

³ *Annual Book of ASTM Standards*, Vol 14.02.

becomes the system sample.

3.2.13 *statistical independence, n*—two sample values are statistically independent if the occurrence of either one in no way affects the probability assigned to the occurrence of the other.

3.2.14 *surrogate sample, n*—a sample, used in the evaluation of a mechanical sampling system, which is comprised of one or more increments collected from a coal stream within the mechanical sampling system in accordance with Practice D 2234, Conditions “A” or “B.” Such a sample may be considered acceptable for evaluation of a mechanical sampling system’s components, excluding the primary cutter, when demonstrated to be equivalent to the reference sample.

3.2.15 *system sample, n*—a sample collected from a test batch or lot of coal by the mechanical sampling system being tested for bias.

3.2.16 *Walsh averages, n*—given a series of observations (differences) x_1, x_2, \dots, x_n , the $n(n+1)/2$ pair-wise averages given by:

$$(x_i + x_j)/2, 1 \leq i \leq j \leq n \quad (1)$$

3.2.16.1 *Discussion*—As an example of Walsh averages, assume one has three observations (differences) designated as x_1, x_2 , and x_3 . There are then a total of $3(4)/2 = 6$ Walsh averages. They are as follows: $x_1, x_2, x_3, (x_1 + x_2)/2, (x_1 + x_3)/2$, and $(x_2 + x_3)/2$.

3.2.17 *Wilcoxon Signed Rank Test, n*—a non-parametric statistical procedure for calculating the point estimate and confidence interval for a sample drawn from a population with symmetric distribution.

4. Summary of Practice

4.1 This practice consists of procedures for comparing material collected by mechanical sampling systems to reference or surrogate samples collected by alternate procedures from individual batches or lots of coal, numbered 1 through n , in chronological order, providing n sets of samples. After collection, the test samples are prepared and analyzed using applicable ASTM test methods. For each measured characteristic, a numerical difference in the measurements between the observed system value and the observed reference value is calculated for each set of samples. Using the statistical procedures described in this practice, the set of differences from the n sets is then examined for evidence of bias between the mechanical system and reference measurements.

4.2 This practice is based on matched-pair experimental designs. The practice describes two procedures of sample collection, paired increment and paired test batch, and two statistical procedures for assessing bias: nonparametric and parametric. The Wilcoxon signed rank test procedure is a nonparametric test, assuming only symmetry of each of the univariate differences, the Hotelling’s T^2 test is a parametric test assuming multivariate normality of the differences, and the Student’s t -test is a parametric univariate test assuming normality of the differences.

5. Significance and Use

5.1 It is intended that these procedures be used to provide an estimate of the bias of a mechanical sampling system used to

collect samples of coal. Mechanical coal-sampling systems are used extensively in industry for collecting samples while coal is being conveyed or transported in various stages of production, shipment, receipt, and use. The bias of the sampling system, in the measurement of coal quality, can have significant commercial and environmental consequences.

5.2 Bias as determined by these procedures need not be a constant or fixed value and can reflect the bias only under the conditions, which prevailed during the test period. Variables including, but not limited to, changes in the operation of the sampling system, the coal transfer operation, or the coal-sampling characteristics can cause changes in test results; therefore, if system bias is unacceptable, correct the cause rather than compensate for it.

5.3 A single bias test may not provide a meaningful generalized expectation of past or future system performance but an ongoing testing program can. Such a program may be established by mutual agreement of the interested parties.

5.4 Data used to draw conclusions regarding bias are subject to sources of error other than those attributable to the biases in the sampling system. Biases introduced by handling, preparation, and analysis of samples could also contribute to the appearance of a system bias. Therefore it is important to carefully follow ASTM standard methods for sampling, sample preparation, and testing, and to exercise careful quality control.

5.5 In all cases, the test plan should approximate normal system operation and not be a source of bias itself. This is especially critical when the sampling system batch processes several consecutive increments at any stage. In this case, the system samples should consist of all the coal from an entire batch.

5.6 Since this practice includes several different methods of sample collection and statistical procedures, the procedures used for both sample collection and statistical processing must be chosen before the test is conducted. This does not preclude subjecting historical test data to alternate statistical procedures for alternative purposes.

6. Apparatus

6.1 *Sample Collection Devices:*

6.1.1 *Stopped-Belt Divider*—A device similar to that illustrated in Fig. 1. The width between the divider plates must be the same throughout the divider, and no less than three times the nominal top size of the coal. Assure the width is sufficient, and the design of the mechanism adequate, to enable quick and easy removal of all coal lying on the conveyor belt between the divider plates, including very fine material.

6.1.2 *Surrogate Reference Sample Collection Tools*—Devices used to subsample internal coal flows of a mechanical sampling system. These devices must be capable of extracting a full stream Type I-A-1 or I-B-1 increments (see Practice D 2234) from a mechanical sampling system stream of coal.

6.2 *Sample Preparation Equipment*—All bias test samples should be prepared using equipment as specified in Method D 2013.

7. Description of Test Procedures

7.1 *Sample Collection:*

7.1.1 This practice offers three basic test designs for bias

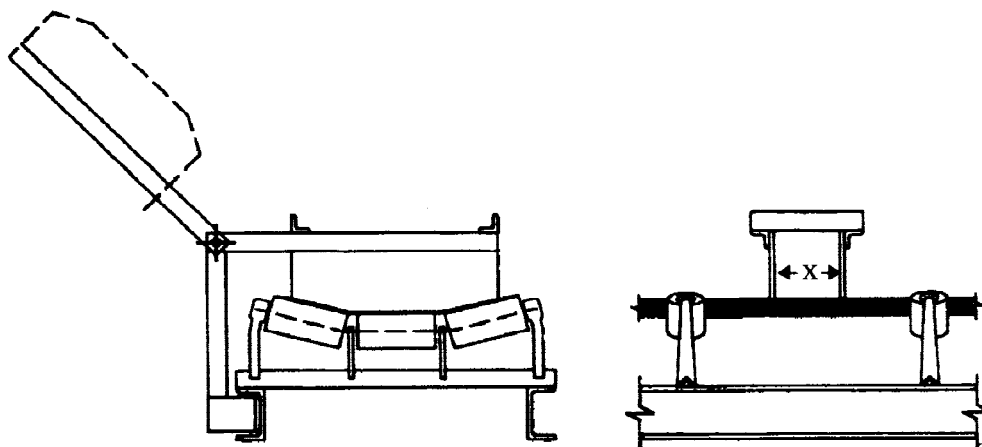

NOTE 1—The “x” dimension shall be no less than three times the nominal top size of the coal but of sufficient width to enable quick and easy removal of all coal lying on the conveyor belt between the divider plates, including very fine coal.

FIG. 1 Bias Test Stopped-Belt Divider

testing of mechanical sampling systems. They are referred to as the paired increment, the paired test batch, and the intraphase test designs. The basic distinguishing features of the designs are given in 7.1.2.1-7.1.4.3. (**Warning**—Collecting test samples on multistage sampling systems, or testing individual system components or combinations of components on multistage systems, by either paired increment or paired batch experimental designs can result in atypical moisture losses because of a disturbance or disruption of routine operating conditions. Disturbance or disruption of routine operating conditions is generally related to one or more of the following: the time interval involved in extraction of increments, interruption of internal flow within the sampling system, and induced ventilation within the sampling system. Every effort must be made to minimize adverse effects of such factors.)

7.1.2 Paired Increment Design:

7.1.2.1 Paired increment procedures involve the collection of system increments and reference samples, which are paired for comparison purposes. Collect reference samples from the same area of the conveyor or as near as possible to the location where the corresponding sampling system’s primary increment(s) is extracted so a close physical association is created. Some variations of the test design can be collecting one reference sample for each sampling system primary increment and bracketing the location from where the system’s primary increment is withdrawn with two reference samples or if the system’s primary increments are normally batched through the remainder of the sampling system. Another option may be collecting multiple system primary increments within the bracket of reference samples.

7.1.2.2 The paired increment experimental design requires intermittent operation of the coal handling and sampling systems because of the need to stop the conveyor to remove reference samples.

7.1.2.3 Operating the sampling system under the control of system logic is the preferred practice. This procedure involves operating under system logic until it initiates collection of a primary increment, then manually tripping the conveyor system by pushing the stop button to shut it down. This technique requires that only the main conveyor shut down, while the

sampling system purges under the routine operating settings of system logic, and may or may not, shut down. System logic timers should continue to operate without interruption.

7.1.2.4 Collect reference increments using a systematic collection scheme.

7.1.2.5 The paired increment design can be used to test individual system components.

7.1.3 Paired Test Batch Design:

7.1.3.1 In the paired-sample test batch design, the system sample and reference sample(s) are collected during some pre-defined period of time or tonnage throughput. The volume of coal processed during the timed or tonnage interval is referred to as a test batch. The system sample is that sample collected from the test batch by the sampling system operating in its normal mode. The reference sample consists of one or more stopped-belt increments taken from the same test batch.

7.1.3.2 The reference sample and mechanical system sample originate from the same test batch of coal.

7.1.3.3 Operate the sampling system at the operating settings preselected for the test, the same for every batch.

7.1.3.4 Use a random sampling scheme developed according to the requirements of Practice E 105. A random start followed by systematic selection of increments thereafter is acceptable practice.

7.1.3.5 The paired test batch design often is used to test the overall mechanical system.

7.1.4 Intraphase Test Design:

7.1.4.1 This testing pertains to obtaining the overall sampling system bias estimate by combining data from two or more separate test phases, one phase of which includes a reference sample. Each test phase obtains data on one or more components or subsystems. The data from the separate test phases are statistically combined for an estimate of the overall system bias. This approach is useful when interruptions to the sampling system would impose an experimentally induced moisture loss. The sampling system uses batch processing instead of linear processing. This approach is also useful when it is necessary to diagnose the cause of a bias discovered by one of the other test procedures.

NOTE 1—In the first phase of a typical two-phase test, the primary sampler is tested for bias using a paired increment test that compares samples collected from or at the discharge of the primary sample conveyor (surrogate samples) with stopped-belt reference samples. If the primary sampler is found to be acceptable, then in the second phase a paired-sample batch test compares surrogate samples, collected in the same manner as the first phase, to system samples to test the remainder of the sampling system.

7.1.4.2 Phased testing takes advantage of the fact that mechanical coal sampling and on-line preparation is a linear process and the overall results of this linear process can be determined by separately investigating the individual parts. The data obtained from individual process parts is combined statistically to obtain an estimate of the overall systems performance.

7.1.4.3 The test data, from the separate phases, are combined by algebraically adding the mean differences and by obtaining an estimate of the overall standard deviation by summing the variances associated with each phase and taking the square root.

7.2 *Statistical Procedures*—The matched pairs experimental design of the test for bias reflects the underlying requirements for meaningful assessment of bias test data. This practice supports both parametric and nonparametric procedures, either of which can encompass univariate or multivariate statistical analysis for assessment and interpretation of results, both of which assume independence of individual differences. The distinction between parametric and nonparametric statistical analysis lies in the assumptions regarding the distribution of the population of differences. Parametric statistical analysis is predicated on a normal distribution.

7.2.1 *Wilcoxon Signed Rank Nonparametric Test, Nonparametric Analysis*—This test is based on creating a superset of the population of differences by differencing every possible combination of the observed differences and sorting them in ascending order. The median of this distribution is taken as the point estimate of bias. Two-sided confidence limits for univariate and multivariate analysis for up to five variables are established based on the Bonferroni inequality, using Table A2.12. Interpretation of the results depends on whether or not the confidence interval encompasses zero for the univariate case, and on whether or not the confidence interval of any one of the variables encompasses zero in the multivariate case.

7.2.2 *Student's t and Hotelling's T^2 Parametric Analysis*—The parametric method requires computation of the mean and the standard deviation of the differences of the variable in question for the univariate case or of each of the variables for the multivariate case. The mean(s) are taken as the point estimate(s) of bias. The confidence interval for the univariate case and the confidence regions for the multivariate case are established using the corresponding standard deviation and Hotelling's T^2 values. Interpretation of the results depends on whether or not the confidence interval falls within the predetermined tolerable bias region (see 8.2.3).

7.2.3 *Variance Addition for Intraphase Test*—Intraphase statistical analysis is conducted using Student's t -test for the paired difference between two means. Mean differences for each test phase are added to arrive at an overall mean difference for the system. The estimated standard deviation of

the combined phases is obtained by addition of the corresponding variances of the phase tests and taking the square root. Interpretation of the results depends on whether or not the confidence interval encompasses zero.

8. Organization and Planning

8.1 *Data Required to Plan Test:*

8.1.1 Obtain information pertinent to operation of the mechanical sampling system so that detailed test procedures can be prepared.

8.1.2 Obtain the layout of the associated coal handling system including description of coal conveyor widths, belt speeds, troughing idler angles, coal flow rates, availability, and permissible conveyor stops and restarts.

8.1.3 Obtain complete sampling system operating information, including sample cutter widths, sample cutter operating intervals and velocities, sample extraction rates for each stage of sampling, sample crusher product top sizes, accessibility for sample collection, and typical lot sizes. Identify adjustments typically made to accommodate different lot sizes or other operating conditions. Sources of information can include design parameters, or physical measurements, or both.

NOTE 2—The condition of and operation of the sampling system can be determined before doing a bias test. It is recommended that the inspection be done in accordance with Guide D 4702, by personnel familiar with the operation of the mechanical sampling system and knowledgeable in ASTM standards.

8.1.4 Obtain a description of coals typically sampled. Include the nominal coal top size, typical quality characteristics, and a description of the type of preparation, such as washed, crushed run-of-mine, or blended coal.

8.2 *Select Test Conditions*—Make the following decisions and selections before the test:

8.2.1 *Selection of Test Coal*—If coals of different quality are available for use in the bias test, a selection of the specific coal(s) to be used must be made before collection of test samples. Efforts should be made to keep the coal quality as consistent as is practical during the test. The user of this practice is cautioned that a change in coal quality could invalidate the statistical results and that bias can change with coal quality.

8.2.2 *Selection of Analytical Test Parameters for the Test:*

8.2.2.1 The specific coal quality characteristics to be used in the bias test should be selected before the test.

8.2.2.2 Make the same analytical determinations on both the reference and system samples. Use the observed values for each of these coal characteristics to make inferences concerning system bias of the sampling system against the chosen reference. A bias test using this practice can be based on one or more characteristics measured for the test comparison. As many as five coal characteristics can be used when testing for bias using the statistical practices in 7.2.1.

8.2.2.3 The greater the number of coal characteristics used in the statistical inference for a fixed number of paired data sets the larger the confidence interval widths will be; thus, the user should give consideration to limiting the number of coal characteristics to those which would yield a reasonable evaluation of the sampling system. Arguments can be made that only determinations of moisture and dry ash are necessary for

evaluating bias of a sampling system, and that it is unlikely bias of other coal characteristics would exist independent of bias of either moisture or dry ash.

8.2.3 Selection of the Largest Tolerable Bias—Select the largest tolerable bias limits (LTB) for the coal characteristics that will be used in the statistical analysis, or review the width of the confidence interval, or size of the confidence ellipsoid, and conclude if the test is sufficiently precise. Refer to the Annexes on statistical procedures for guidance.

8.2.4 Selection of Sampler Operating Mode—Sampler operation and coal transfer rate should not change during the course of the test. If the sampler has the ability to operate in different modes (different lot sizes, tonnage rates, time or mass basis, and so forth), the user must select the mode or modes of operation in which the sampler is to be tested.

8.2.5 Selection of Collection Method—Under Section 7, the user will need to select an increment collection method. The methods listed and described in 7.1.2 and 7.1.3 are collection of paired data on an increment basis and collection of paired data on a test-batch basis.

8.2.6 Selection of Method to Collect Reference Samples—Practice D 2234 lists several different methods for increment collection. Condition “A” (Stopped-Belt Cut), in which a full cross-section of coal is removed from the stopped main conveyor belt, is considered the reference method and is the highest order of sampling methods available. For the purpose of this practice, surrogate samples can be obtained from increments collected by methods other than stopping the main coal flow belt. Such surrogate samples, collected in accordance with Practice D 2234, Conditions “A” or “B” and when proven free of significant bias relative to reference samples may be considered acceptable for evaluation of a mechanical sampling system’s components, excluding the primary cutter.

8.2.7 Selection of Statistical Procedures—Select a statistical procedure by which to evaluate the data from the bias test. The statistical procedures listed and described in Annex A2 are as follows: Wilcoxon Signed Rank Nonparametric test (nonparametric), and Hotelling’s T^2 (parametric), and combined variance for intraphase tests. When there is only one coal characteristic used for the test, then the Hotelling’s T^2 is equivalent to the Student’s t -test.

8.2.8 Selection of Number of Paired Data Sets—In the absence of information on the variance of differences of the paired data sets, it is not possible to estimate, before the test, how many data sets are needed to detect a bias at the largest tolerable bias (LTB) chosen for the test. Recognizing this lack of information, it has been a common practice in the industry to initially collect between 20 and 40 sets of data, with the actual number being determined by perception of the variability of the coal and the use to be made of the test results. At any time during the test, analysis of current data collected can enable the user to determine if additional data sets are needed to reach specified test precision. Alternatively, if information is available on the sampling variance, or on the variance of differences of similarly collected paired samples from the test coal or similar coals, the information can be used to optimize test design. Using such information, Practice E 122 can be helpful in planning the number of paired data sets.

8.2.9 Selection of Test Batch Size—Select the batch size of coal that will be used for the data sets. For the paired increment test design, this can be the region of coal on the conveyor from which the reference and system sample increments are to be collected. For a paired test-batch design, this can be based on time or tonnage. In either test design, the batch size should be approximately the same throughout the entire test period. Test batch size should take into consideration the mass of retained system sample and the necessity to ensure that small retained samples are not adversely affected by the sample collection process (change in moisture, etc.). See Annex A1-Annex A3 for additional information regarding the selection of test-batch size.

8.2.10 Selection of Number of Reference Increments/Samples per Test Batch of Coal—Select the number of reference increments/samples per test batch. For a paired increment test design this can be one or more increments such that the reference sample is collected nearby or brackets the region of coal from which the system’s increment(s) are to be obtained. For a paired test-batch design, one or more reference increments can be collected during the chosen batch interval. In general, the fewer the number of increments per test batch, the higher the variance of paired sample differences and the lower the power of the test for a given number of paired sets. For coal relatively uniform within individual test batches, only one or two reference increments might be adequate. For a coal with characteristics highly variable within individual test batches, it may be necessary to take more reference increments from each test batch.

8.2.11 Selection of Reference Sample Collection Times and Preparing a Collection Schedule:

8.2.11.1 Prepare a schedule for collection of reference increments from test batches before beginning the collection of bias test samples.

8.2.11.2 The reference increments should be collected from the test batch interval such that all coal within that test batch interval has an opportunity to be collected over the course of the test. Selection of timing for collection of the reference samples must be by a random method.

8.2.11.3 Operate the mechanical sampling system continuously during the processing of each test batch. If the test batch size is smaller than a lot, consider operating the system continuously while processing several consecutive test batches.

8.2.11.4 The test batch interval should include only the cumulative time during which coal is flowing.

8.2.11.5 Precautions should be taken, in the choice of increment collection times, that test sample collection minimally affects the coal flow through the sampling system.

8.2.11.6 Samples collected for a bias test should be collected in accordance with Practice D 2234 (Conditions “A” or “B”).

8.3 General Sample Handling—As rapidly as possible, all test samples should be sealed in moisture proof containers, identified, weighed, and stored in a protected area before beginning the next test batch interval. Some coals are more susceptible to oxidation, which may require additional precautions such as vapor and gas impervious storage containers.

NOTE 3—Any unaccounted for moisture change in the test samples, that

results from collection and handling, will show up as either an under or over-estimates of any moisture difference attributed to the sampling system.

8.3.1 Preparation of Test Samples:

8.3.1.1 Minimum final masses (after preparation), which conform to the limits specified in Method D 2013 are recommended. It is recognized that this will not be possible in all cases with the system sample. Samples with masses less than those specified in Method D 2013 shall only be used by mutual agreement of the interested parties. It must be recognized that the use of system sample masses, which substantially are less than those recommended can decrease the ability of the test to detect a bias or cause false detection of bias. Small sample masses could be detrimental especially to the determination of moisture bias if the samples are not handled with special care to preserve moisture.

8.3.1.2 Reweigh all reference increments, all reference sieve increments, and all system samples before combining, crushing, or dividing. List each weight in the bias test report.

8.3.1.3 Multiple reference samples, collected during a single test batch, can be physically composited, prepared, and analyzed or individually prepared and analyzed, and the weighted average analysis result of the individual samples used as the reference value.

8.3.1.4 Sample preparation can be performed wholly or in part either at the test site or at the testing laboratory. In either case, the sample preparation procedures shall be consistent with all test samples subject to conditions imposed by Practice D 2234 and Method D 2013.

8.3.1.5 Measure and include in the total moisture result the moisture condensation adhering to the interior of the sample containers used for transporting and storing samples.

8.3.2 Laboratory Analysis of the Test Samples:

8.3.2.1 Use consistent procedures for laboratory analysis throughout the test for bias.

8.3.2.2 Every effort should be made to analyze the test samples quickly to avoid deterioration of the test samples as a

result of lengthy storage time.

8.3.2.3 All test samples from a test batch shall be concurrently processed and analyzed. The purpose is to minimize introducing systematic error resulting from differences in treatment during preparation and analysis.

8.3.2.4 Laboratory record keeping and quality control practices shall be in accordance with Guide D 4621. Record and report the results of all analytical determinations on each test sample.

8.4 Information to Be Obtained and Reported:

8.4.1 A log of test sample collection activities during sample collection should be kept. Include the following information:

8.4.1.1 Weather conditions, including temperature and state of precipitation.

8.4.1.2 Date, starting and ending time of the collection of each test sample.

8.4.1.3 The weight and number of increments comprising each test sample shall be recorded. It is recommended that all test samples be weighed before and after preparation to monitor preparation losses.

8.4.1.4 Identification of responsible personnel involved in the test sample collection process.

8.4.1.5 A general description of the origin and identification of the coal used during the test for bias.

8.4.1.6 Date, time, and description of failures of mechanical sampling equipment or coal-handling equipment, and duration of downtime.

8.4.1.7 Description of the sampling system and its operation during the test.

8.4.1.8 Description of test design, sample collection, sample handling, and statistical methods used for the test.

8.4.1.9 Analytical test results on each sample.

8.4.1.10 Results of all statistical analysis.

9. Keywords

9.1 coal sampling; mechanical sampling; statistical analysis

ANNEXES

(Mandatory Information)

A1. COLLECTION OF REFERENCE SAMPLES

A1.1 Reference Samples

A1.1.1 A stopped-belt sample provides the best possible reference sample and is the accepted method for bias test reference sample collection.

A1.1.2 One or several reference increments can be collected per test set (see Table A1.1). If more than one reference increment is collected, the system samples can be compared to each individual reference increment or to the weighted average composite value of the combined reference increments. It is acceptable to take two reference increments that bracket the area from which the sampling system's primary increment will be withdrawn. When two or more reference increments are collected per belt stoppage, they should be collected simulta-

TABLE A1.1 Schedule for Collection of Stopped-Belt Increments

NOTE 1—Test batch interval = 60 min
 Stopped-belt increments per test batch = 3
 $k = 60/3 = 20$ min
 $U = 2(20) = 40$

Test Batch	Random No.	T_1	T_2	T_3
1	16	8.0	28.0	48.0
2	37	18.5	38.5	58.5
3	2	1.0	21.0	41.0
4	35	17.5	37.5	57.5
5	26	13.0	33.0	53.0
—	—	—	—	—
—	—	—	—	—