



Designation: C 729 – 75 (Reapproved 2000)

Standard Test Method for Density of Glass by the Sink-Float Comparator¹

This standard is issued under the fixed designation C 729; the number immediately following the designation indicates the year of original adoption or, in the case of revision, the year of last revision. A number in parentheses indicates the year of last reapproval. A superscript epsilon (ϵ) indicates an editorial change since the last revision or reapproval.

1. Scope

1.1 This test method covers the determination of the density of glass or nonporous solids of density from 1.1 to 3.3 g/cm³. It can be used to determine the apparent density of ceramics or solids, preferably of known porosity.

1.2 *This standard does not purport to address all of the safety concerns, if any, associated with its use. It is the responsibility of the user of this standard to establish appropriate safety and health practices and determine the applicability of regulatory limitations prior to use.*

2. Referenced Documents

2.1 ASTM Standards:

C 693 Test Method for Density of Glass by Buoyancy²

D 1217 Test Method for Density and Relative Density (Specific Gravity) of Liquids by Bingham Pycnometer³

E 12 Terminology Relating to Density and Specific Gravity of Solids, Liquids, and Gases⁴

E 29 Practice for Using Significant Digits in Test Data to Determine Conformance with Specification⁵

E 77 Test Method for Inspection and Verification of Thermometers⁶

F 77 Test Method for Apparent Density of Ceramics for Electron Device and Semiconductor Application²

3. Summary of Method

3.1 The specimen of unknown density is compared with a reference standard of known density. The specimen to be measured is placed in a test tube containing a solution whose density at 35°C is within 0.0200 g/cm³ of the density of the specimen at 25°C. The solution is prepared using miscible liquids of known densities bracketing the desired range. The tube also contains a glass density reference standard whose density at 35°C is close to that of the solution at 35°C; the tube is immersed in a variable-temperature comparator bath. Ini-

tially the solutions, specimen, and standard are at a temperature near 25°C, and both the standard and the specimen float in the solution. The temperature of the system is raised at a uniform rate. Because the expansion coefficient of the solution is higher than that of the glass standard and specimen, both the standard and the specimen will sink (settle) in the solution. The temperatures at which the specimen and standard reach the mid-point of the test tube are noted and by use of special tables, the density of the specimen is obtained.

3.2 *Range of a Given Density Solution*— A given density solution can be used to measure specimens whose density is within ± 0.0200 g/cm³ of the density of the solution at 35°C, by operating the comparator bath in the range 25 to 45°C.

4. Significance and Use

4.1 The sink-float comparator method of test for glass density provides the most accurate (yet convenient for practical applications) method of evaluating the density of small pieces or specimens of glass. The data obtained are useful for daily quality control of production, acceptance or rejection under specifications, and for special purposes in research and development.

4.2 Although this test scope is limited to a density range from 1.1 to 3.3 g/cm³, it may be extended (in principle) to higher densities by the use of other miscible liquids (Test Method F 77) such as water and thallium malonate-formate (approximately 5.0 g/cm³). The stability of the liquid and the precision of the test may be reduced somewhat, however, at higher densities.

5. Apparatus

5.1 *Single Tube and Multiple-Tube Comparators* (Method E 77)— A single-tube comparator can be constructed from materials readily available in a typical laboratory, and useful if one wishes to measure the density of materials within a fairly narrow range, or if only a few tests need to be run each day. The multiple-tube comparator can be purchased commercially.⁷ It is useful if materials with a wide range of density must be tested or if many specimens must be tested each day. The comparators shall consist of the following:

5.1.1 *Single-Tube Comparator* (Fig. 1):

⁷ A multiple-tube comparator is available from American Glass Research, Inc., Box 149, Butler, PA 16001.

¹ This test method is under the jurisdiction of ASTM Committee C-14 on Glass and Glass Products and is the direct responsibility of Subcommittee C14.04 on Physical and Mechanical Properties.

Current edition approved Aug. 29, 1975. Published November 1975. Originally published as C 729 – 72 T. Last previous edition C 729 – 72 T.

² *Annual Book of ASTM Standards*, Vol 15.02.

³ *Annual Book of ASTM Standards*, Vol 05.01.

⁴ *Annual Book of ASTM Standards*, Vol 15.05.

⁵ *Annual Book of ASTM Standards*, Vol 14.02.

⁶ *Annual Book of ASTM Standards*, Vol 14.03.

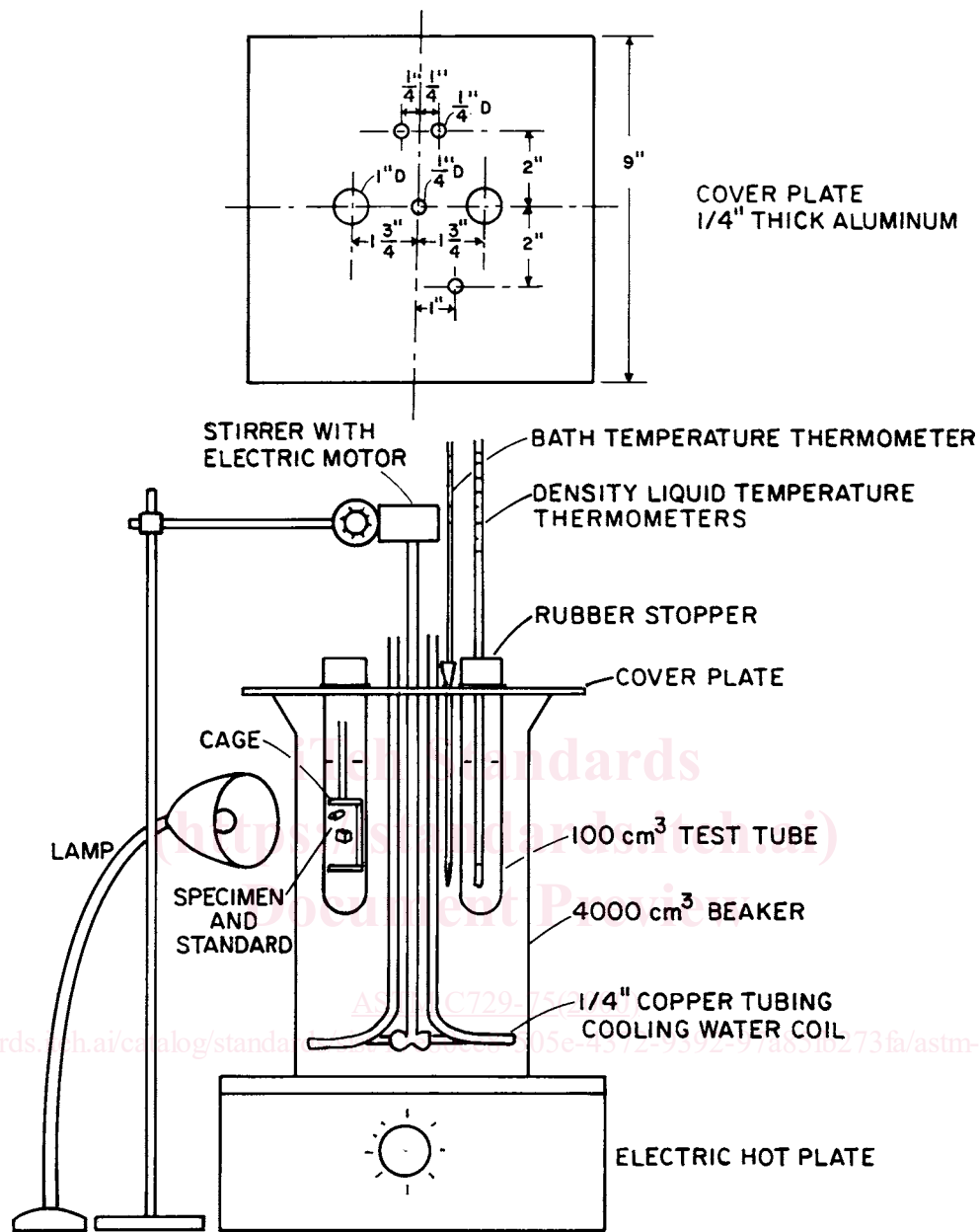

Metric Equivalents

in.	1/4	1/2	1	1 1/4	2	9
mm	6.4	12.7	25.4	44.4	51	229

FIG. 1 Single Tube Sink-Float Density Apparatus

5.1.1.1 *Circulating Water Bath*, consisting of a 4000-cm³ beaker, a cover plate supporting test tubes and thermometer, a cooling water coil made from copper tubing, an electrically driven stirrer, and containing an immersion heater with rheostat for controlling heating rate, or heated by an external heat source such as a hot plate.

5.1.1.2 *Test Tubes*, two, 100-cm³ capacity. The cover plate supports the test tubes, which extended into the water bath. One tube contains the density solution, the test specimen, the standard, and a glass or TFE-fluorocarbon cage (Fig. 2) that

keeps the specimens immersed in the solution. The second test tube contains density solution and a thermometer; both test tubes employ rubber stoppers for supporting the cage or thermometer.

5.1.1.3 *Thermometers*, two, mercury, readable to 0.1°C between 20 and 50°C. One thermometer passes through a rubber stopper supported by the cover plate into the water bath. The second thermometer passes through a rubber stopper into

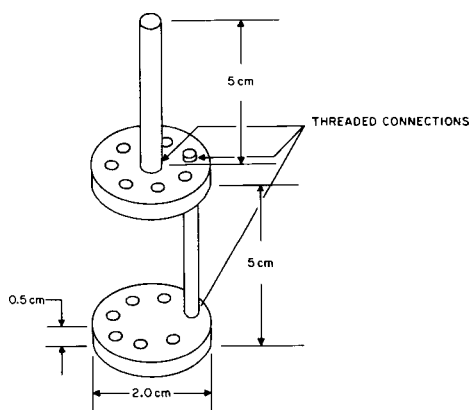

FIG. 2 TFE-Fluorocarbon Cage for 100-mL Test Tube

the test tube that contains density solution only. Thermistor thermometers can be used instead of mercury thermometers, if desired.

5.1.2 *Multiple-Tube Comparator*—The commercially obtainable multiple-tube comparator employs the same principle as the single-tube comparator, except that the multiple-tube type contains additional specimen tubes. These specimen tubes may contain similar density solutions if a large number of specimens with similar density are to be measured; they may contain density solutions of differing density if a number of specimens with a range of densities are to be measured.

6. Reagents and Materials

6.1 *Density Reference Standards*—The reference standard shall be a solid piece of glass with a volume between 0.10 and 0.15 cm³, and a ratio of major to minor dimensions not exceeding 2.0. It shall have a smooth surface and be free of seeds, cords, and cracks. A quantity of such standards may be cut from a 20-g piece of glass similarly free of defects, with density at 25°C (ρ_{25}) known to ± 0.0001 g/cm³. The density of such a standard glass can be determined to ± 0.00001 g/cm³ by a precise buoyancy method.⁸ Determine the settling temperature of each reference standard to the nearest 0.1°C and discard any that deviate more than 0.1°C from mean temperature. Less precise density standards are commercially available.⁹

6.2 *Density Solution*—The following organic liquids¹⁰ are mixed to provide a solution of the desired density:

6.2.1 *Isopropyl Salicylate*, density (25°C) approximately 1.10 g/cm³ or *alpha-bromonaphthalene*, density (25°C) approximately 1.49 g/cm³.

6.2.2 *sym-Tetrabromoethane*, density (25°C) approximately 2.96 g/cm³.

6.2.3 *Methylene Iodide*, density (25°C) approximately 3.32 g/cm³.

⁸ Bowman, H. A., and Schoonover, R. M., "Procedure for High Precision Density Determinations by Hydrostatic Weighing," *Journal of Research*, National Bureau of Standards, 71 C, 3, 1967, p. 179.

⁹ Sources include:

American Glass Research, Inc., Box 149, Butler, PA 16001, Emhart Corporation, Hartford Division, P.O. Box 1620, Hartford, CT 06102, and Engineered Materials, P.O. Box 363, Church St. Station, New York, NY 10008.

¹⁰ These liquids are available from most chemical supply companies.

NOTE 1—Methylene iodide, *sym*-tetrabromoethane, and *alpha*-bromonaphthalene are light-sensitive. These liquids should be stored in light-protective containers. A piece of copper wire in the methylene iodide container will help retard decomposition.

6.2.4 The density solution consists of mixtures of isopropyl salicylate and *sym*-tetrabromoethane for densities between 1.10 and 2.96 g/cm³, and of *sym*-tetrabromoethane and methylene iodide for densities between 2.96 and 3.32 g/cm³. Proper amounts of the two liquids to be used are found by simultaneous solution of:

$$\rho_s V_s = \rho_1 V_1 + \rho_2 V_2 \quad (1)$$

$$V_s = V_1 + V_2 \quad (2)$$

$$\rho_s = (\rho_1 V_1 + \rho_2 V_2) / (V_1 + V_2) \quad (3)$$

where:

ρ_s = density of solution – density of standard at 35°C,

V_s = volume of solution to be prepared,

ρ_1 and ρ_2 = densities of the component liquids at 35°C, and

V_1 and V_2 = volumes of the component liquids at 35°C.

6.2.5 *Solution Preparation*—Approximate volumes of liquids required to supply desired density ρ_s are shown in Table 1. Mix the two required volumes of liquids 1 and 2 (6.2.4) in a beaker, set on a hot plate, and warm to 35°C. Place a density

TABLE 1 Volumes of Liquids for Solutions of Various Densities

ρ_s g/cm ³ at 35°C	Volume of Material Used, cm ³		
	Isopropyl Salicylate	<i>sym</i> -Tetra- bromo- ethane	Methylene Iodide
2.103	135	165	...
2.136	127	173	...
2.190	120	180	...
2.222	115	185	...
2.236	113	187	...
2.257	109	191	...
2.291	104	196	...
2.315	100	200	...
2.335	95	205	...
2.363	92	208	...
2.403	85	215	...
2.434	80	220	...
2.448	78	222	...
2.473	74	226	...
2.495	70	230	...
2.511	68	232	...
2.529	65	235	...
2.560	60	240	...
2.589	56	244	...
2.596	54	246	...
2.619	50	250	...
2.633	48	252	...
2.669	42	258	...
2.702	37	263	...
2.728	33	267	...
2.757	28	272	...
2.812	19	281	...
2.847	13	287	...
2.863	10	290	...
2.893	6	294	...
2.933	...	300	1
2.960	...	277	23
2.999	...	248	52
3.035	...	214	86
3.054	...	198	102
3.096	...	168	132