

INTERNATIONAL STANDARD

NORME INTERNATIONALE



**Miniature fuses –
Part 2: Cartridge fuse-links**

**Coupe-circuit miniatures –
Partie 2: Cartouches**

[IEC 60127-2:2014](#)

<https://standards.iteh.ai/catalog/standards/sist/4bf6fa33-9f64-43a3-b30b-ccc32c1f62ba/iec-60127-2-2014>

STANDARD PREVIEW
(standards.iteh.ai)





THIS PUBLICATION IS COPYRIGHT PROTECTED

Copyright © 2020 IEC, Geneva, Switzerland

All rights reserved. Unless otherwise specified, no part of this publication may be reproduced or utilized in any form or by any means, electronic or mechanical, including photocopying and microfilm, without permission in writing from either IEC or IEC's member National Committee in the country of the requester. If you have any questions about IEC copyright or have an enquiry about obtaining additional rights to this publication, please contact the address below or your local IEC member National Committee for further information.

Droits de reproduction réservés. Sauf indication contraire, aucune partie de cette publication ne peut être reproduite ni utilisée sous quelque forme que ce soit et par aucun procédé, électronique ou mécanique, y compris la photocopie et les microfilms, sans l'accord écrit de l'IEC ou du Comité national de l'IEC du pays du demandeur. Si vous avez des questions sur le copyright de l'IEC ou si vous désirez obtenir des droits supplémentaires sur cette publication, utilisez les coordonnées ci-après ou contactez le Comité national de l'IEC de votre pays de résidence.

IEC Central Office
3, rue de Varembe
CH-1211 Geneva 20
Switzerland

Tel.: +41 22 919 02 11
info@iec.ch
www.iec.ch

About the IEC

The International Electrotechnical Commission (IEC) is the leading global organization that prepares and publishes International Standards for all electrical, electronic and related technologies.

About IEC publications

The technical content of IEC publications is kept under constant review by the IEC. Please make sure that you have the latest edition, a corrigendum or an amendment might have been published.

IEC publications search - webstore.iec.ch/advsearchform

The advanced search enables to find IEC publications by a variety of criteria (reference number, text, technical committee,...). It also gives information on projects, replaced and withdrawn publications.

IEC Just Published - webstore.iec.ch/justpublished

Stay up to date on all new IEC publications. Just Published details all new publications released. Available online and once a month by email.

IEC Customer Service Centre - webstore.iec.ch/csc

If you wish to give us your feedback on this publication or need further assistance, please contact the Customer Service Centre: sales@iec.ch.

Electropedia - www.electropedia.org

The world's leading online dictionary on electrotechnology, containing more than 22 000 terminological entries in English and French, with equivalent terms in 16 additional languages. Also known as the International Electrotechnical Vocabulary (IEV) online.

IEC Glossary - std.iec.ch/glossary

67 000 electrotechnical terminology entries in English and French extracted from the Terms and definitions clause of IEC publications issued between 2002 and 2015. Some entries have been collected from earlier publications of IEC TC 37, 77, 86 and CISPR.

A propos de l'IEC

La Commission Electrotechnique Internationale (IEC) est la première organisation mondiale qui élabore et publie des Normes internationales pour tout ce qui a trait à l'électricité, à l'électronique et aux technologies apparentées.

A propos des publications IEC

Le contenu technique des publications IEC est constamment revu. Veuillez vous assurer que vous possédez l'édition la plus récente, un corrigendum ou amendement peut avoir été publié.

Recherche de publications IEC -

webstore.iec.ch/advsearchform

La recherche avancée permet de trouver des publications IEC en utilisant différents critères (numéro de référence, texte, comité d'études,...). Elle donne aussi des informations sur les projets et les publications remplacées ou retirées.

IEC Just Published - webstore.iec.ch/justpublished

Restez informé sur les nouvelles publications IEC. Just Published détaille les nouvelles publications parues. Disponible en ligne et une fois par mois par email.

Service Clients - webstore.iec.ch/csc

Si vous désirez nous donner des commentaires sur cette publication ou si vous avez des questions contactez-nous: sales@iec.ch.

Electropedia - www.electropedia.org

Le premier dictionnaire d'électrotechnologie en ligne au monde, avec plus de 22 000 articles terminologiques en anglais et en français, ainsi que les termes équivalents dans 16 langues additionnelles. Egalement appelé Vocabulaire Electrotechnique International (IEV) en ligne.

Glossaire IEC - std.iec.ch/glossary

67 000 entrées terminologiques électrotechniques, en anglais et en français, extraites des articles Termes et définitions des publications IEC parues entre 2002 et 2015. Plus certaines entrées antérieures extraites des publications des CE 37, 77, 86 et CISPR de l'IEC.



IEC 60127-2

Edition 3.1 2020-09
CONSOLIDATED VERSION

INTERNATIONAL STANDARD

NORME INTERNATIONALE



**Miniature fuses –
Part 2: Cartridge fuse-links**

**Coupe-circuit miniatures –
Partie 2: Cartouches**

[IEC 60127-2:2014](#)

<https://standards.iteh.ai/catalog/standards/sist/4bf6fa33-9f64-43a3-b30b-ccc32c1f62ba/iec-60127-2-2014>

INTERNATIONAL
ELECTROTECHNICAL
COMMISSION

COMMISSION
ELECTROTECHNIQUE
INTERNATIONALE

ICS 29.120.50

ISBN 978-2-8322-8885-6

**Warning! Make sure that you obtained this publication from an authorized distributor.
Attention! Veuillez vous assurer que vous avez obtenu cette publication via un distributeur agréé.**

REDLINE VERSION

VERSION REDLINE



**Miniature fuses –
Part 2: Cartridge fuse-links**

**Coupe-circuit miniatures –
Partie 2: Cartouches**

[IEC 60127-2:2014](#)

<https://standards.iteh.ai/catalog/standards/sist/4bf6fa33-9f64-43a3-b30b-ccc32c1f62ba/iec-60127-2-2014>

STANDARD PREVIEW
(standards.iteh.ai)

CONTENTS

FOREWORD.....	4
INTRODUCTION.....	6
1 Scope and object.....	7
2 Normative references	7
3 Terms and definitions	7
4 General requirements	7
5 Standard ratings	7
6 Marking	8
7 General notes on tests	8
8 Dimensions and construction	14
9 Electrical requirements	16
10 Standard sheets	18
Annex A (normative) Miniature fuse-links with wire terminations	39
A.1 General.....	39
A.2 Scope	39
A.3 General notes on tests.....	39
A.3.1 Type tests.....	39
A.3.2 Testing schedule	39
A.3.3 Test bases for tests	40
A.4 Dimensions and construction	42
A.4.1 Dimensions.....	42
A.4.2 Mechanical tests on terminations.....	42
A.4.3 Solderability of terminations.....	43
A.4.4 Resistance to soldering heat.....	43
A.5 Electrical requirements	43
A.5.1 Voltage drop.....	44
A.5.2 Time/current characteristic at normal ambient temperature	44
A.5.3 Breaking capacity	44
A.5.4 Fuse-link temperature.....	44
Annex B (normative) Cartridge fuse-links with DC ratings	45
B.1 General.....	45
B.2 General notes on tests	45
B.3 Marking.....	46
B.4 Electrical requirements	46
Bibliography.....	49
Figure 1 – Test fuse-base for 5 mm × 20 mm and 6,3 mm × 32 mm fuse-links – Rated currents up to and including 6,3 A (see 7.3)	11
Figure 2 – Test fuse-base for 5 mm × 20 mm and 6,3 mm × 32 mm fuse-links – Rated currents exceeding 6,3 A (see 7.3)	12
Figure 3 – Test fuse-base for breaking capacity tests (see 7.3)	13
Figure 4 – Axial pull test apparatus.....	15
Figure 5 – Alignment gauge (see 8.4)	16

Figure 6 – Typical test circuit for breaking-capacity tests for high-breaking capacity fuse-links (see 9.3)	17
Figure 7 – Typical test circuit for breaking-capacity tests for low- and enhanced-breaking capacity fuse-links (see 9.3)	17
Figure A.1 – Test board	40
Figure A.2 – Test base	41
Figure A.3 – Dimensions of fuse-link with wire terminations	42
Figure B.1 – Test circuits for breaking capacity tests	47
Table 1 – Testing schedule for individual ampere ratings	9
Table 2 – Testing schedule for maximum ampere rating of a homogeneous series	9
Table 3 – Testing schedule for minimum ampere rating of a homogeneous series	10
Table A.1 – Testing schedule	40
Table B.1 – Testing schedule	45
Table B.2 – Time constant	46

iTeh STANDARD PREVIEW
(standards.iteh.ai)

[IEC 60127-2:2014](https://standards.iteh.ai/catalog/standards/sist/4bf6fa33-9f64-43a3-b30b-ccc32c1f62ba/iec-60127-2-2014)

<https://standards.iteh.ai/catalog/standards/sist/4bf6fa33-9f64-43a3-b30b-ccc32c1f62ba/iec-60127-2-2014>

INTERNATIONAL ELECTROTECHNICAL COMMISSION

MINIATURE FUSES –

Part 2: Cartridge fuse-links

FOREWORD

- 1) The International Electrotechnical Commission (IEC) is a worldwide organization for standardization comprising all national electrotechnical committees (IEC National Committees). The object of IEC is to promote international co-operation on all questions concerning standardization in the electrical and electronic fields. To this end and in addition to other activities, IEC publishes International Standards, Technical Specifications, Technical Reports, Publicly Available Specifications (PAS) and Guides (hereafter referred to as “IEC Publication(s)”). Their preparation is entrusted to technical committees; any IEC National Committee interested in the subject dealt with may participate in this preparatory work. International, governmental and non-governmental organizations liaising with the IEC also participate in this preparation. IEC collaborates closely with the International Organization for Standardization (ISO) in accordance with conditions determined by agreement between the two organizations.
- 2) The formal decisions or agreements of IEC on technical matters express, as nearly as possible, an international consensus of opinion on the relevant subjects since each technical committee has representation from all interested IEC National Committees.
- 3) IEC Publications have the form of recommendations for international use and are accepted by IEC National Committees in that sense. While all reasonable efforts are made to ensure that the technical content of IEC Publications is accurate, IEC cannot be held responsible for the way in which they are used or for any misinterpretation by any end user.
- 4) In order to promote international uniformity, IEC National Committees undertake to apply IEC Publications transparently to the maximum extent possible in their national and regional publications. Any divergence between any IEC Publication and the corresponding national or regional publication shall be clearly indicated in the latter.
- 5) IEC itself does not provide any attestation of conformity. Independent certification bodies provide conformity assessment services and, in some areas, access to IEC marks of conformity. IEC is not responsible for any services carried out by independent certification bodies.
- 6) All users should ensure that they have the latest edition of this publication.
- 7) No liability shall attach to IEC or its directors, employees, servants or agents including individual experts and members of its technical committees and IEC National Committees for any personal injury, property damage or other damage of any nature whatsoever, whether direct or indirect, or for costs (including legal fees) and expenses arising out of the publication, use of, or reliance upon, this IEC Publication or any other IEC Publications.
- 8) Attention is drawn to the Normative references cited in this publication. Use of the referenced publications is indispensable for the correct application of this publication.
- 9) Attention is drawn to the possibility that some of the elements of this IEC Publication may be the subject of patent rights. IEC shall not be held responsible for identifying any or all such patent rights.

This consolidated version of the official IEC Standard and its amendment has been prepared for user convenience.

IEC 60127-2 edition 3.1 contains the third edition (2014-09) [documents 32C/493/FDIS and 32C/498/RVD] and its amendment 1 (2020-09) [documents 32C/587/FDIS and 32C/591/RVD].

In this Redline version, a vertical line in the margin shows where the technical content is modified by amendment 1. Additions are in green text, deletions are in strikethrough red text. A separate Final version with all changes accepted is available in this publication.

International Standard IEC 60127-2 has been prepared by subcommittee 32C: Miniature fuses, of IEC technical committee 32: Fuses.

This third edition constitutes a technical revision.

This edition includes the following significant technical changes with respect to the previous edition:

- a) add 4 new standard sheets 7 up to 10.

This International Standard is to be used in conjunction with IEC 60127-1:2006.

This publication has been drafted in accordance with the ISO/IEC Directives, Part 2.

The clauses of this standard supplement, modify or replace the corresponding clauses in IEC 60127-1.

Where there is no corresponding clause or subclause in this standard, the clause or subclause of IEC 60127-1 applies without modification as far as is reasonable. When this standard states “addition”, “modification” or “replacement”, the relevant text in IEC 60127-1 is to be adapted accordingly.

The committee has decided that the contents of the base publication and its amendment will remain unchanged until the stability date indicated on the IEC web site under "<http://webstore.iec.ch>" in the data related to the specific publication. At this date, the publication will be

- reconfirmed,
- withdrawn,
- replaced by a revised edition, or
- amended.

IMPORTANT – The 'colour inside' logo on the cover page of this publication indicates that it contains colours which are considered to be useful for the correct understanding of its contents. Users should therefore print this document using a colour printer.

INTRODUCTION

According to the wish expressed by the users of miniature fuses, all standards, recommendations and other documents relating to miniature fuses should have the same publication number in order to facilitate reference to fuses in other specifications, for example, equipment specifications.

Furthermore, a single publication number and subdivision into parts would facilitate the establishment of new standards, because clauses and subclauses containing general requirements need not be repeated.

The new IEC 60127 series is thus subdivided as follows:

IEC 60127, *Miniature fuses* (general title).

IEC 60127-1, *Miniature fuses – Part 1: Definitions for miniature fuses and general requirements for miniature fuse-links*

IEC 60127-2, *Miniature fuses – Part 2: Cartridge fuse-links*

IEC 60127-3, *Miniature fuses – Part 3: Sub-miniature fuse-links*

IEC 60127-4, *Miniature fuses – Part 4: Universal modular fuse-links (UMF) – Through-hole and surface mount types*

IEC 60127-5, *Miniature fuses – Part 5: Guidelines for quality assessment of miniature fuse-links*

IEC 60127-6, *Miniature fuses – Part 6: Fuse-holders for miniature fuse-links*

IEC 60127-7, *Miniature fuses – Part 7: Miniature fuse-links for special applications*

IEC 60127-8, (Free for further documents)

IEC 60127-9, (Free for further documents)

IEC 60127-10, *Miniature fuses – Part 10: User guide for miniature fuses*

This Part of IEC 60127 covers additional requirements, test equipment and standard sheets.

The SI system of units is used throughout this standard.

MINIATURE FUSES –

Part 2: Cartridge fuse-links

1 Scope and object

This part of IEC 60127 relates to special requirements applicable to cartridge fuse-links for miniature fuses with dimensions measuring 5 mm × 20 mm and 6,3 mm × 32 mm for the protection of electric appliances, electronic equipment and component parts thereof, normally intended for use indoors.

It does not apply to cartridge fuse-links for appliances intended to be used under special conditions, such as in corrosive or explosive atmospheres.

This standard applies in addition to the requirements of IEC 60127-1.

The object of this standard is to define special and additional test methods for cartridge fuse-links applying in addition to the requirements of IEC 60127-1.

2 Normative references

The following documents, in whole or in part, are normatively referenced in this document and are indispensable for its application. For dated references, only the edition cited applies. For undated references, the latest edition of the referenced document (including any amendments) applies.

<https://standards.iteh.ai/catalog/standards/sist/4bf6fa33-9f64-43a3-b30b-ccc32c1f62ba/iec-60127-2-2014>
IEC 60068-2-20, *Environmental testing – Part 2-20: Tests – Test T: Test methods for solderability and resistance to soldering heat of devices with leads*

IEC 60068-2-21:2006, *Environmental testing – Part 2-21: Tests – Test U: Robustness of terminations and integral mounting devices*

IEC 60127-1:2006, *Miniature fuses – Part 1: Definitions for miniature fuses and general requirements for miniature fuse-links*
Amendment 1:2011

ISO 3, *Preferred numbers – Series of preferred numbers*

3 Terms and definitions

For the purposes of this document, the terms and definitions given in IEC 60127-1:2006, Clause 3, apply.

4 General requirements

Clause 4 of IEC 60127-1:2006 applies.

5 Standard ratings

Clause 5 of IEC 60127-1:2006 applies.

6 Marking

Clause 6 of IEC 60127-1:2006 applies except as follows:

6.1 Addition:

- e) A symbol denoting the rated breaking capacity. This symbol shall be placed between the marking for the rated current and the marking for the rated voltage.

These symbols are

H denoting high breaking capacity,

L denoting low breaking capacity,

E denoting enhanced breaking capacity.

EXAMPLES of marking:

T	3	1	5	L	2	5	0	V
---	---	---	---	---	---	---	---	---

		F	4	H	2	5	0	V
--	--	---	---	---	---	---	---	---

T	3	1	5	E	2	5	0	V
---	---	---	---	---	---	---	---	---

6.4 Add the following paragraph after the first paragraph:

The values for “d” and “s” shall be 0,8 mm ± 0,2 mm.

7 General notes on tests

Clause 7 of IEC 60127-1:2006 applies except as follows:

7.2.1 Addition:

For testing individual fuse ratings, the number of fuse-links required is 48, of which 12 are kept as spares. The testing schedule is shown in Table 1.

For the maximum ampere rating of a homogeneous series, the number of fuse-links required is 48, of which 22 are kept as spares. The testing schedule is shown in Table 2.

For the minimum ampere rating of a homogeneous series the number of fuse-links required is 33, of which 16 are kept as spares. The testing schedule is shown in Table 3.

Table 1 – Testing schedule for individual ampere ratings

Sub-clause	Description	Fuse-link no.																				
		1-6	7-9	8-10	12-13	14-15	16-17	18-19	20-21	22-24	25-26	27-28	29-30	31-32	33-34	35-36	37-38	39-40	41-42	43-44	45-46	47-48
9.4 ^a	Endurance test	X																				
9.2.2 ^a	Test at elevated temperature ^b					X																
9.2.1 ^a	Time/current characteristics 10 I_N		X																			
	4 I_N							X														
	2,75 I_N												X									
	2,0 I_N or 2,1 I_N																			X		
9.3	Breaking capacity test: Rated breaking capacity				X																	
	5 times the rated current						X															
	10 times the rated current									X												
	50 times the rated current											X										
	250 times the rated current																X					
8.3	Terminations (end cap test)		X					X					X							X		
8.5 ^a	Soldered joints	X	X			X		X					X							X		
6.2 ^a	Legibility and indelibility of marking		X					X					X							X		

^a These subclauses are to be found in IEC 60127-1.
^b Applicable only when specified on the standard sheet.

Table 2 – Testing schedule for maximum ampere rating of a homogeneous series

Sub-clause	Description	Fuse-link numbers in decreasing value of voltage drop													
		1-6	7-9	10-12	13-17	18-27	28-29	30-31	32-33	34-35	36-37	38-39	40-42	43-45	46-48
9.4 ^a	Endurance test	X													
9.2.2 ^a	Test at elevated temperature ^b						X								
9.2.1 ^a	Time/current characteristics 10 I_N		X												
	4 I_N							X							
	2,75 I_N									X					
	2,0 I_N or 2,1 I_N													X	
9.3	Rated breaking capacity				X										
8.3	Terminations (end cap test)		X					X		X				X	
8.5 ^a	Soldered joints	X	X				X	X		X				X	
6.2 ^a	Legibility and indelibility of marking		X					X		X				X	

^a These subclauses are to be found in IEC 60127-1.
^b Applicable only when specified on the standard sheet.

Table 3 – Testing schedule for minimum ampere rating of a homogeneous series

Sub-clause	Description	Fuse-link numbers in decreasing value of voltage drop						
		1-6	7 8 9	10 11 12	13-17	18-27	28 29 30	31 32 33
9.4 ^a	Endurance test	X						
9.2.1 ^a	Time/current characteristics		X					
	10 I_N 2,0 I_N or 2,1 I_N						X	
9.3	Rated breaking capacity				X			
^a These subclauses are to be found in IEC 60127-1.								

Replacement:

7.3 Fuse-bases for tests

For tests that require a fuse-base for mounting the fuse-links, bases according to Figures 1, 2 or 3, shall be used as appropriate.

The contact resistance between each contact and a silvered brass piece having the same nominal dimensions and shape as the fuse-link to be tested shall not exceed 3 mΩ and is measured under the following conditions:

- a) in order to prevent the breakdown of thin insulating layers on the contacts, the e.m.f. of the circuit shall not exceed 20 mV (d.c. or a.c. peak);
- b) in order to prevent undue heating of the contacts, the current flowing shall not exceed 1 A.

Metal parts of the fuse-base, except the spring and connections, shall be made of brass. Brass parts of the fuse-base and of the gauge for measuring contact resistance shall have a copper content of between 58 % and 70 %. Contacts shall be silver-plated.

For fuse-links with rated currents up to and including 6,3 A, a fuse-base according to Figure 1 shall be used. The contact force shall be between 4 N and 6 N. The flexible lead and terminal wires shall be of copper and shall have a cross-sectional area of 1 mm²; the length of each of the terminal wires being approximately 500 mm.

For fuse-links with rated currents exceeding 6,3 A, a fuse-base according to Figure 2 shall be used. The contact force shall be between 8 N and 12 N. The flexible lead and terminal wires shall be of copper and shall have a cross-sectional area of 6 mm²; the length of each of the terminal wires being approximately 500 mm.

For breaking capacity tests, a fuse-base according to Figure 3, with the same contact force and conductor cross-sectional area as for the base in Figure 2, shall be used.

Dimensions in millimetres with tolerance of 0,1 mm

Fuse-links	a mm	b mm
5 mm × 20 mm	20	48
6,3 mm × 32 mm	32	60

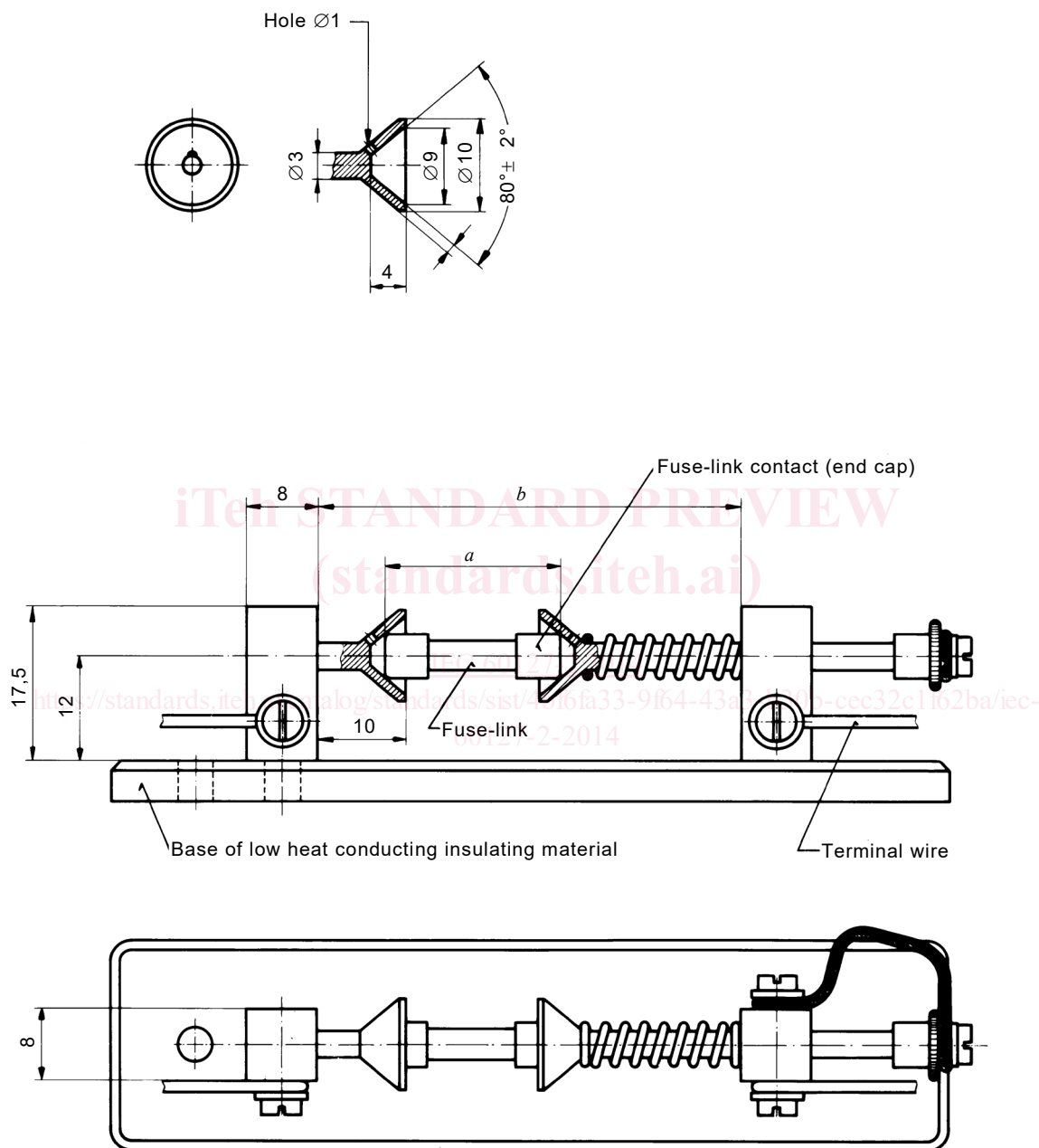

IEC

Figure 1 – Test fuse-base for 5 mm × 20 mm and 6,3 mm × 32 mm fuse-links –
 Rated currents up to and including 6,3 A ~~(see 7.3)~~