

# INTERNATIONAL STANDARD

# NORME INTERNATIONALE



**Miniature fuses –  
Part 3: Sub-miniature fuse-links**

**Coupe-circuit miniatures –  
Partie 3: Éléments de remplacement subminiatures**

<https://standards.iteh.ai/catalog/standards/sist/deaa9877-976b-47d4-8427-46aa2d4e1800/iec-60127-3-2015>



## THIS PUBLICATION IS COPYRIGHT PROTECTED

Copyright © 2020 IEC, Geneva, Switzerland

All rights reserved. Unless otherwise specified, no part of this publication may be reproduced or utilized in any form or by any means, electronic or mechanical, including photocopying and microfilm, without permission in writing from either IEC or IEC's member National Committee in the country of the requester. If you have any questions about IEC copyright or have an enquiry about obtaining additional rights to this publication, please contact the address below or your local IEC member National Committee for further information.

Droits de reproduction réservés. Sauf indication contraire, aucune partie de cette publication ne peut être reproduite ni utilisée sous quelque forme que ce soit et par aucun procédé, électronique ou mécanique, y compris la photocopie et les microfilms, sans l'accord écrit de l'IEC ou du Comité national de l'IEC du pays du demandeur. Si vous avez des questions sur le copyright de l'IEC ou si vous désirez obtenir des droits supplémentaires sur cette publication, utilisez les coordonnées ci-après ou contactez le Comité national de l'IEC de votre pays de résidence.

IEC Central Office  
3, rue de Varembe  
CH-1211 Geneva 20  
Switzerland

Tel.: +41 22 919 02 11  
[info@iec.ch](mailto:info@iec.ch)  
[www.iec.ch](http://www.iec.ch)

### About the IEC

The International Electrotechnical Commission (IEC) is the leading global organization that prepares and publishes International Standards for all electrical, electronic and related technologies.

### About IEC publications

The technical content of IEC publications is kept under constant review by the IEC. Please make sure that you have the latest edition, a corrigendum or an amendment might have been published.

#### IEC publications search - [webstore.iec.ch/advsearchform](http://webstore.iec.ch/advsearchform)

The advanced search enables to find IEC publications by a variety of criteria (reference number, text, technical committee, ...). It also gives information on projects, replaced and withdrawn publications.

#### IEC online collection - [oc.iec.ch](http://oc.iec.ch)

Discover our powerful search engine and read freely all the publications previews. With a subscription you will always have access to up to date content tailored to your needs.

#### IEC Just Published - [webstore.iec.ch/justpublished](http://webstore.iec.ch/justpublished)

Stay up to date on all new IEC publications. Just Published details all new publications released. Available online and once a month by email.

#### Electropedia - [www.electropedia.org](http://www.electropedia.org)

The world's leading online dictionary on electrotechnology, containing more than 22 000 terminological entries in English and French, with equivalent terms in 18 additional languages. Also known as the International Electrotechnical Vocabulary (IEV) online.

#### IEC Customer Service Centre - [webstore.iec.ch/csc](http://webstore.iec.ch/csc)

If you wish to give us your feedback on this publication or need further assistance, please contact the Customer Service Centre: [sales@iec.ch](mailto:sales@iec.ch).

### A propos de l'IEC

La Commission Electrotechnique Internationale (IEC) est la première organisation mondiale qui élabore et publie des Normes internationales pour tout ce qui a trait à l'électricité, à l'électronique et aux technologies apparentées.

### A propos des publications IEC

Le contenu technique des publications IEC est constamment revu. Veuillez vous assurer que vous possédez l'édition la plus récente, un corrigendum ou amendement peut avoir été publié.

#### Recherche de publications IEC -

[webstore.iec.ch/advsearchform](http://webstore.iec.ch/advsearchform)

La recherche avancée permet de trouver des publications IEC en utilisant différents critères (numéro de référence, texte, comité d'études, ...). Elle donne aussi des informations sur les projets et les publications remplacées ou retirées.

#### IEC online collection - [oc.iec.ch](http://oc.iec.ch)

Découvrez notre puissant moteur de recherche et consultez gratuitement tous les aperçus des publications. Avec un abonnement, vous aurez toujours accès à un contenu à jour adapté à vos besoins.

#### IEC Just Published - [webstore.iec.ch/justpublished](http://webstore.iec.ch/justpublished)

Restez informé sur les nouvelles publications IEC. Just Published détaille les nouvelles publications parues. Disponible en ligne et une fois par mois par email.

#### Electropedia - [www.electropedia.org](http://www.electropedia.org)

Le premier dictionnaire d'électrotechnologie en ligne au monde, avec plus de 22 000 articles terminologiques en anglais et en français, ainsi que les termes équivalents dans 16 langues additionnelles. Egalement appelé Vocabulaire Electrotechnique International (IEV) en ligne.

#### Service Clients - [webstore.iec.ch/csc](http://webstore.iec.ch/csc)

Si vous désirez nous donner des commentaires sur cette publication ou si vous avez des questions contactez-nous: [sales@iec.ch](mailto:sales@iec.ch).



IEC 60127-3

Edition 3.1 2020-07  
CONSOLIDATED VERSION

# INTERNATIONAL STANDARD

# NORME INTERNATIONALE



**Miniature fuses –  
Part 3: Sub-miniature fuse-links**

**Coupe-circuit miniatures –  
Partie 3: Éléments de remplacement subminiatures**

<https://standards.iteh.ai/catalog/standards/sist/deaa9877-976b-47d4-8427-46aa2d4e1800/iec-60127-3-2015>

INTERNATIONAL  
ELECTROTECHNICAL  
COMMISSION

COMMISSION  
ELECTROTECHNIQUE  
INTERNATIONALE

ICS 29.120.50

ISBN 978-2-8322-9540-3

**Warning! Make sure that you obtained this publication from an authorized distributor.  
Attention! Veuillez vous assurer que vous avez obtenu cette publication via un distributeur agréé.**



## REDLINE VERSION

## VERSION REDLINE



**Miniature fuses –  
Part 3: Sub-miniature fuse-links**

**Coupe-circuit miniatures –  
Partie 3: Éléments de remplacement subminiatures**

<https://standards.iteh.ai/catalog/standards/sist/deaa9877-976b-47d4-8427-46aa2d4e1800/iec-60127-3-2015>

STANDARD PREVIEW  
(standards.iteh.ai)

## CONTENTS

FOREWORD .....	3
INTRODUCTION .....	5
1 Scope .....	6
2 Normative references .....	6
3 Terms and definitions .....	6
4 General requirements .....	6
5 Standard ratings .....	7
6 Marking .....	7
7 General notes on tests .....	7
8 Dimensions and construction .....	9
9 Electrical requirements .....	10
10 Standard sheets .....	18
Annex A (normative) Sub-miniature fuse-links according to standard sheet 3 and 4 with optional DC ratings .....	29
Figure 1 – Standard test board (see 7.3).....	8
Figure 2 – Standard test base for test board (see 7.3) .....	9
Figure 3 – Typical circuit for breaking capacity tests for low breaking capacity sub- miniature fuse-links (see 9.3).....	11
Figure A 1 – Test circuits for breaking capacity tests .....	31
Table 1 – Testing schedule for individual ampere ratings, standard sheet 1 and 2 .....	13
Table 2 – Testing schedule for individual ampere ratings, standard sheet 3 and 4 .....	14
Table 3 – Testing schedule for maximum ampere rating of a homogeneous series, standard sheet 1 and 2 .....	15
Table 4 – Testing schedule for maximum ampere rating of a homogeneous series, standard sheet 3 and 4 .....	16
Table 5 – Testing schedule for minimum ampere rating of a homogeneous series, standard sheet 1 to 4 .....	17
Table A.1 – Testing schedule.....	29
Table A.2 – Time constant .....	30

## INTERNATIONAL ELECTROTECHNICAL COMMISSION

### MINIATURE FUSES –

#### Part 3: Sub-miniature fuse-links

#### FOREWORD

- 1) The International Electrotechnical Commission (IEC) is a worldwide organization for standardization comprising all national electrotechnical committees (IEC National Committees). The object of IEC is to promote international co-operation on all questions concerning standardization in the electrical and electronic fields. To this end and in addition to other activities, IEC publishes International Standards, Technical Specifications, Technical Reports, Publicly Available Specifications (PAS) and Guides (hereafter referred to as “IEC Publication(s)”). Their preparation is entrusted to technical committees; any IEC National Committee interested in the subject dealt with may participate in this preparatory work. International, governmental and non-governmental organizations liaising with the IEC also participate in this preparation. IEC collaborates closely with the International Organization for Standardization (ISO) in accordance with conditions determined by agreement between the two organizations.
- 2) The formal decisions or agreements of IEC on technical matters express, as nearly as possible, an international consensus of opinion on the relevant subjects since each technical committee has representation from all interested IEC National Committees.
- 3) IEC Publications have the form of recommendations for international use and are accepted by IEC National Committees in that sense. While all reasonable efforts are made to ensure that the technical content of IEC Publications is accurate, IEC cannot be held responsible for the way in which they are used or for any misinterpretation by any end user.
- 4) In order to promote international uniformity, IEC National Committees undertake to apply IEC Publications transparently to the maximum extent possible in their national and regional publications. Any divergence between any IEC Publication and the corresponding national or regional publication shall be clearly indicated in the latter.
- 5) IEC itself does not provide any attestation of conformity. Independent certification bodies provide conformity assessment services and, in some areas, access to IEC marks of conformity. IEC is not responsible for any services carried out by independent certification bodies.
- 6) All users should ensure that they have the latest edition of this publication.
- 7) No liability shall attach to IEC or its directors, employees, servants or agents including individual experts and members of its technical committees and IEC National Committees for any personal injury, property damage or other damage of any nature whatsoever, whether direct or indirect, or for costs (including legal fees) and expenses arising out of the publication, use of, or reliance upon, this IEC Publication or any other IEC Publications.
- 8) Attention is drawn to the Normative references cited in this publication. Use of the referenced publications is indispensable for the correct application of this publication.
- 9) Attention is drawn to the possibility that some of the elements of this IEC Publication may be the subject of patent rights. IEC shall not be held responsible for identifying any or all such patent rights.

**This consolidated version of the official IEC Standard and its amendment has been prepared for user convenience.**

**IEC 60127-3 edition 3.1 contains the third edition (2015-01) [documents 32C/501/FDIS and 32C/506/RVD] and its amendment 1 (2020-07) [documents 32C/586/FDIS and 32C/589/RVD].**

**In this Redline version, a vertical line in the margin shows where the technical content is modified by amendment 1. Additions are in green text, deletions are in strikethrough red text. A separate Final version with all changes accepted is available in this publication.**

International Standard IEC 60127-3 has been prepared by subcommittee 32C: Miniature fuses, of IEC technical committee 32: Fuses.

This edition includes the following significant technical changes with respect to the previous edition:

- a) add a rectangular shape fuse-link as alternative in standard sheets 3 and 4;
- b) add a small cartridge fuse-link as alternative in standard sheets 2, 3 and 4;
- c) add the rated currents up to 10A in standard sheets 2, 3 and 4;
- d) add Subclause 6.5;
- e) add Subclause 9.7;
- f) the extra samples for termination test (E1 to E6) will be chosen by random and not sorted by voltage drop in Table 1, 2, 3, and 4.

This publication has been drafted in accordance with the ISO/IEC Directives, Part 2.

This International Standard is to be used in conjunction with IEC 60127-1:2006, *Miniature fuses – Part 1: Definitions for miniature fuses and general requirements for miniature fuse-links* and its Amendment 1 (2011).

The clauses of this standard supplement, modify or replace the corresponding clauses in IEC 60127-1.

Where there is no corresponding clause or subclause in this standard, the clause or subclause of IEC 60127-1 applies without modification as far as is reasonable. When this standard states “addition” or “replacement”, the relevant text in IEC 60127-1 is to be adapted accordingly.

A list of all parts in the IEC 60127 series, published under the general title *Miniature fuses*, can be found on the IEC website.

The committee has decided that the contents of the base publication and its amendment will remain unchanged until the stability date indicated on the IEC web site under "http://webstore.iec.ch" in the data related to the specific publication. At this date, the publication will be

- reconfirmed,
- withdrawn,
- replaced by a revised edition, or
- amended.

**IMPORTANT – The 'colour inside' logo on the cover page of this publication indicates that it contains colours which are considered to be useful for the correct understanding of its contents. Users should therefore print this document using a colour printer.**



## INTRODUCTION

According to the wish expressed by the users of miniature fuses, all standards, recommendations and other documents relating to miniature fuses should have the same publication number in order to facilitate reference to fuses in other specifications, for example, equipment specifications.

Furthermore, a single publication number and subdivision into parts would facilitate the establishment of new standards, because clauses and subclauses containing general requirements need not be repeated.

The new IEC 60127 series is thus subdivided as follows:

IEC 60127, *Miniature fuses* (general title)

IEC 60127-1, *Miniature fuses – Part 1: Definitions for miniature fuses and general requirements for miniature fuse-links*

IEC 60127-2, *Miniature fuses – Part 2: Cartridge fuse-links*

IEC 60127-3, *Miniature fuses – Part 3: Sub-miniature fuse-links*

IEC 60127-4, *Miniature fuses – Part 4: Universal modular fuse-links (UMF) – Through-hole and surface mount types*

IEC 60127-5, *Miniature fuses – Part 5: Guidelines for quality assessment of miniature fuse-links*

IEC 60127-6, *Miniature fuses – Part 6: Fuse-holders for miniature fuse-links*

IEC 60127-7, *Miniature fuses – Part 7: Miniature fuse-links for special applications*

IEC 60127-8, (Free for further documents)

IEC 60127-9, (Free for further documents)

IEC 60127-10, *Miniature fuses – Part 10: User guide for miniature fuses*

This part of IEC 60127 covers additional requirements, test equipment and standard sheets.

The SI system of units is used throughout this standard.

## MINIATURE FUSES –

### Part 3: Sub-miniature fuse-links

#### 1 Scope

This part of IEC 60127 is applicable to sub-miniature fuse-links adapted to printed circuits and used for the protection of electric appliances, electronic equipment and component parts thereof, normally intended to be used indoors.

It does not apply to sub-miniature fuse-links for appliances intended to be used under special conditions, such as in a corrosive or explosive atmosphere.

This standard applies in addition to the requirements of IEC 60127-1.

The object of this standard is to define special and additional test methods for sub-miniature fuse-links applying in addition to the requirements of IEC 60127-1.

#### 2 Normative references

The following documents, in whole or in part, are normatively referenced in this document and are indispensable for its application. For dated references, only the edition cited applies. For undated references, the latest edition of the referenced document (including any amendments) applies.

[IEC 60127-3:2015](#)

IEC 60068-2-21, *Environmental testing – Part 2-21: Tests – Test U: Robustness of terminations and integral mounting devices* 27-3-2015

IEC 60127-1:2006, *Miniature fuses – Part 1: Definitions for miniature fuses and general requirements for miniature fuse-links*  
Amendment 1:2011

IEC 60695-11-5, *Fire hazard testing – Part 11-5: Test flames – Needle-flame test method – Apparatus, confirmatory test arrangement and guidance*

IEC 61249-2-7, *Materials for printed boards and other interconnecting structures – Part 2-7: Reinforced base materials clad and unclad – Epoxide woven E-glass laminated sheet of defined flammability (vertical burning test), copper-clad*

ISO 3, *Preferred numbers – Series of preferred numbers*

#### 3 Terms and definitions

For the purposes of this document, the terms and definitions in Clause 3 of IEC 60127-1:2006 apply.

#### 4 General requirements

Clause 4 of IEC 60127-1:2006 applies.

## 5 Standard ratings

Clause 5 of IEC 60127-1:2006 applies.

## 6 Marking

Clause 6 of IEC 60127-1:2006 applies except as follows:

*Addition:*

**6.4** Sub-miniature fuse-links according to standard sheets 3 and 4 may be provided with markings for the rated current, the rated voltage and the time/current characteristic on the top so that they are visible when the fuse-link is mounted.

*Additional subclause:*

**6.5** Where marking is impractical due to space limitations, the relevant information should appear on the smallest package and in the manufacturer's technical literature.

## 7 General notes on tests

Clause 7 of IEC 60127-1:2006 applies except as follows:

*Addition:*

**7.2.1** For testing individual fuse ratings according to standard sheets 1 and 2, the number of sub-miniature fuse-links required is 66, of which 12 are kept as spares. The testing schedule is shown in Table 1.

For testing individual fuse ratings according to standard sheets 3 and 4, the number of fuse-links required is 51, of which 12 are kept as spares. The testing schedule is shown in Table 2.

For the maximum ampere rating of a homogeneous series, the number of fuse-links required in the case of fuse-links in accordance with standard sheets 1 and 2 is 56, of which 22 are kept as spares. The testing schedule is shown in Table 3. The number of fuse-links required in the case of fuse-links in accordance with standard sheets 3 and 4 is 51, of which 22 are kept as spares. The testing schedule is shown in Table 4.

For the minimum ampere rating of a homogeneous series the number of fuse-links required is 38, of which 16 are kept as spares. The test schedule is shown in Table 5.

In addition to the test mentioned in 7.2.1 of IEC 60127-1:2006, sub-miniature fuse-links shall be taken and shall be tested or inspected in accordance with the following item e):

e) Sub-miniature fuse-link terminations (8.3)

*Replacement:*

### 7.3 Fuse-bases for testing

Fuse-links shall be mounted upon the appropriate test board (see Figure 1) by soldering.

This test board shall then be mounted on the test fuse-base (Figure 2). The test board shall be made of epoxide woven glass fabric copper-clad laminated sheet, as defined in IEC 61249-2-7.

The nominal sheet thickness shall be 1,6 mm.

The nominal thickness of the cooper layer shall be 0,035 mm (0,070 mm above 5 A).

Metal parts of the fuse-base shall be made of brass with copper content between 58 % and 70 %. Contact parts shall be silver-plated.

When two or more sub-miniature fuse-links are tested in series, the fuse-bases shall be located so that there will be a spacing of not less than 50 mm between any two sub-miniature fuse-links under test. The conductor connecting the fuse-bases together and connecting the fuse-bases to the ammeter and the source of supply shall be insulated copper wire. The length of each conductor shall be 250 mm and the cross-sectional area of the wire shall be approximately 1 mm<sup>2</sup>.

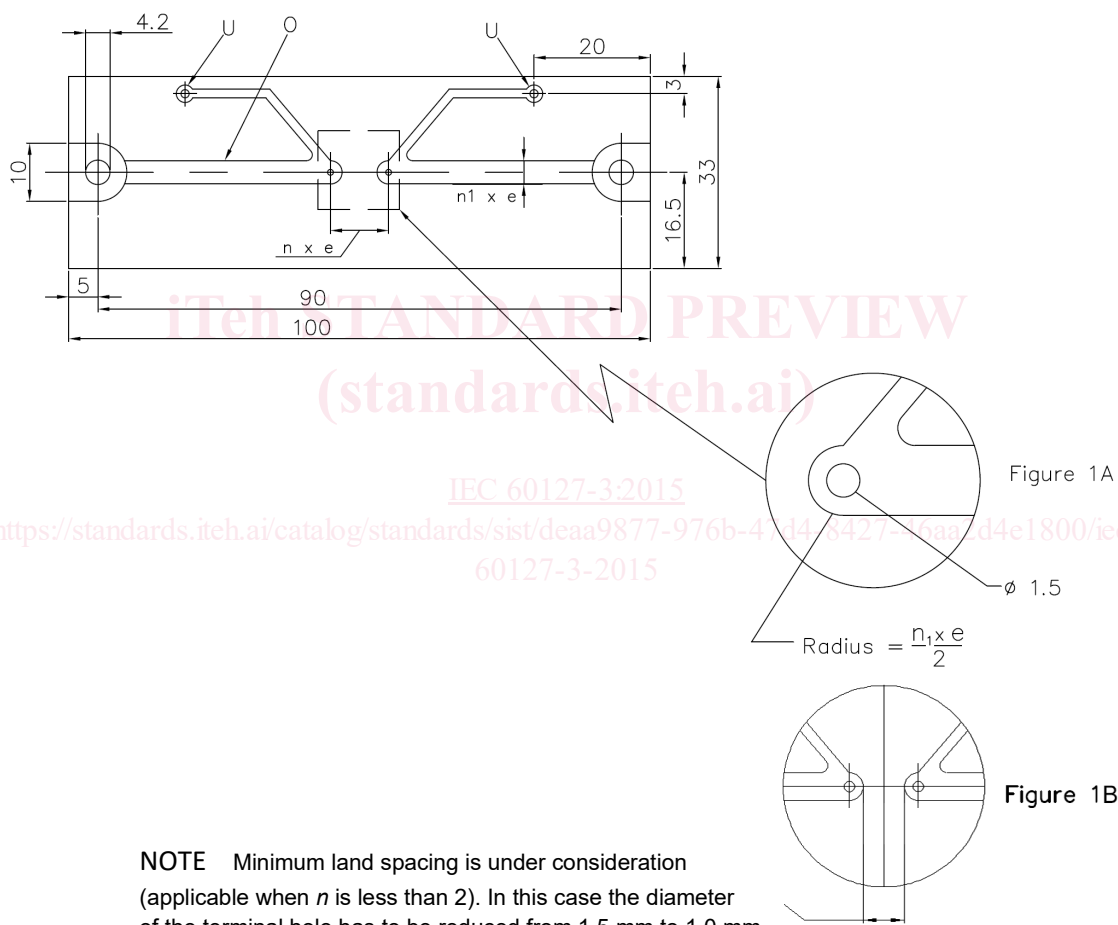

IEC

*Dimensions in millimetres*

**Key**

- O copper layer, thickness 0,035 mm (0,070 mm for rated currents above 5 A)
- U connection for voltage drop measurement
- e 2,54 mm
- n 1,2,3 ... (to be adapted depending on the length of the fuse-link)
- n<sub>1</sub> 1 for fuse-links up to and including 5 A  
2 for fuse-links above 5 A

**Figure 1 – Standard test board (see 7.3)**

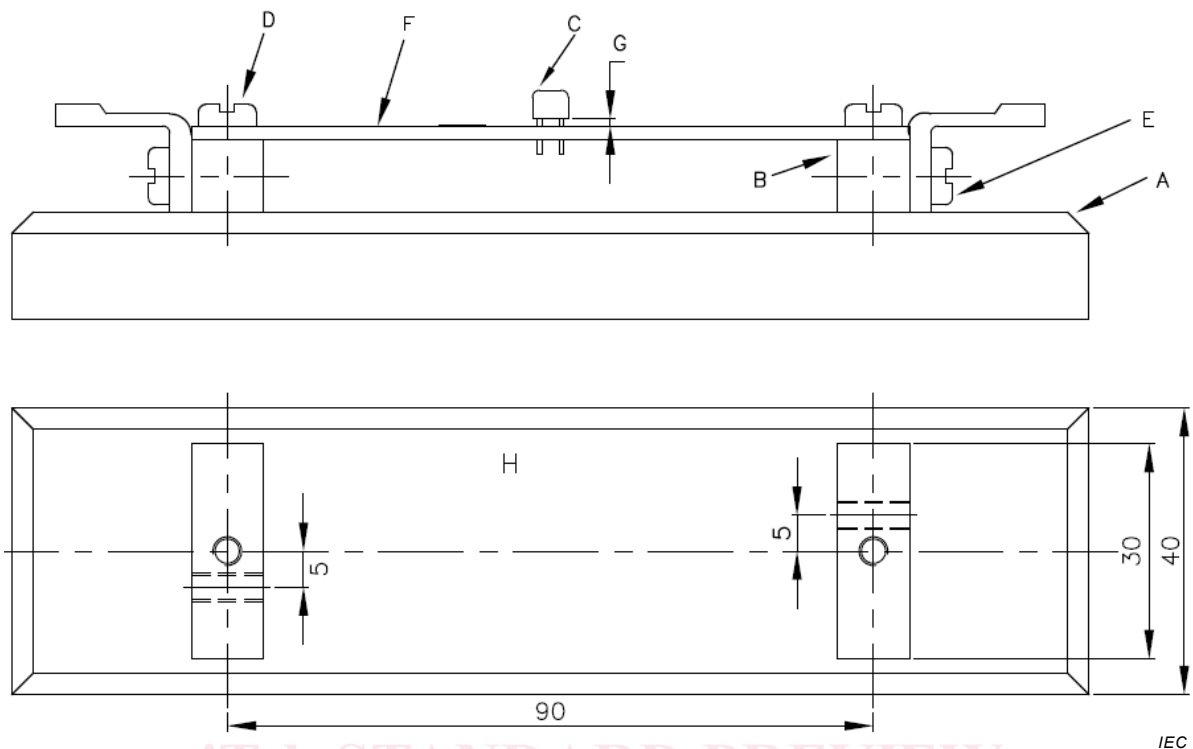

IEC

Dimensions in millimetres

**Key**

- A base of low heat conducting material, thickness 10 mm
- B brass electrodes 10 mm square
- C sub-miniature fuse-link soldered in place
- D fixing screws
- E contact screws holding solder terminal
- F printed circuit board (see Figure 1)
- G space between sub-miniature fuse-link enclosure and board equals  $(0,5 \pm 0,25)$  mm or for tubular fuse-link 1 mm
- H top view of base with 10 mm square brass electrodes

**Figure 2 – Standard test base for test board (see 7.3)**

**8 Dimensions and construction**

Clause 8 of IEC 60127-1:2006 applies except as follows.

**8.2 Construction**

*Addition:*

The sub-miniature fuse-link shall be resistant to heat according to 9.7 of IEC 60127-1:2006 and to fire in accordance with IEC 60695-11-5 (needle-flame test).

The duration of the application of the test flame is 10 s.

Not required for glass or ceramic.

Compliance is checked by inspection.

This standard is based on the assumption that the case of the sub-miniature fuse-link is made of glass, ceramic or similar non-combustible material. For other material, such as the optional insulating sleeve or epoxy coating or similar material shown on standard sheet 2, 3 or 4 additional tests are under consideration.

*Addition:*

### 8.3 Sub-miniature fuse-link terminations

The sub-miniature fuse-link terminations should be firmly attached so that it is not possible to remove them without damaging the sub-miniature fuse-link.

The samples are pre-conditioned by immersion in water for 24 h at a temperature between 15 °C and 35 °C.

Terminations shall withstand the mechanical forces likely to be encountered during normal use. With the sub-miniature fuse-link held in a fixed position, each terminal in turn is subjected at ambient temperature to the forces laid down in this standard. These forces shall be exerted in the direction of the axis of the terminal and applied progressively without jerks. Test sample groups shall be equally divided among the specific termination tests stipulated in the relevant standard sheets.

Present test methods are to be performed in accordance with IEC 60068-2-21.

- For the tensile test ( $U_{a1}$ ), the force applied shall be 10 N.
- For the thrust test ( $U_{a2}$ ), the force applied shall be 2 N.
- For the bending test ( $U_b$ ), if applicable, the force applied shall be 5 N and the number of bends shall be one.

At the conclusion of testing, the sub-miniature fuse-link terminations shall remain firmly attached and the voltage drop shall not exceed the maximum allowed in the relevant standard sheet.

### 8.4 Alignment and configuration of terminations

*Replacement:*

The sub-miniature fuse-link terminations shall be designed to permit easy installation on printed circuit wiring boards having a grid system of holes located on 2,54 mm centres, or into fuse-bases having a spacing between the terminations which is compatible with the 2,54 mm grid system.

NOTE Attention is drawn to the fact that in some parts of the world the value  $e = 2,54$  mm is still in use by printed circuit designers. (See IEC 60127-4:2012, 8.4, NOTE 1.)

## 9 Electrical requirements

Clause 9 of IEC 60127-1:2006 applies except as follows.

### 9.1 Voltage drop

*Addition:*

The use of a high impedance voltmeter is recommended for measuring the voltage drop. Voltage drop shall be measured at the points marked with U in Figure 1.

### 9.3 Breaking capacity

#### 9.3.1 Operating conditions

*Addition:*

Typical test circuits for a.c. and d.c. are given in Figure 3.

When alternating current is stipulated by the relevant standard sheets, the circuit power factor shall be larger than 0,95. To obtain this result, the circuit shall be adjusted by the use of resistors with negligible inductance.

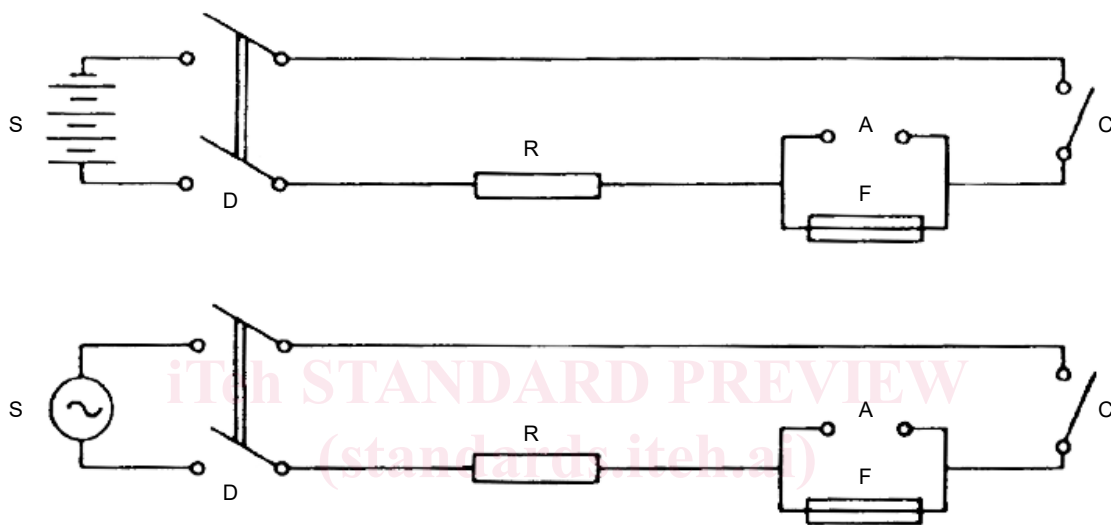

IEC 60127-3:2015

IEC

<https://standards.iteh.ai/catalog/standards/sist/deaa9877-976b-47d4-8427-46aa2d4e1800/iec-60127-3-2015>

#### Key

A = removable link used for calibration

C = contactor that makes the circuit

D = switch to disconnect the source of supply

F = fuse-link under test

S – source of supply, impedance less than 10 % of total impedance of the circuit

R = series resistor, adjusted to obtain correct prospective current

**Figure 3 – Typical circuit for breaking capacity tests for low breaking capacity sub-miniature fuse-links (see 9.3)**

#### 9.3.2 Criteria for satisfactory performance

*Addition:*

In addition to the criteria of failure prescribed in IEC 60127-1, in each of the tests, the subminiature fuse-link shall operate satisfactorily without any of the following phenomena:

- fusing together of the contacts or terminations;
- illegibility of marking after test;
- piercing of the external surfaces visible to the naked eye.

The following phenomena are neglected:

- black spots on the sub-miniature fuse-link terminations;
- small deformations of the sub-miniature fuse-link terminations;