



Designation: D 6767 – 02

Standard Test Method for Pore Size Characteristics of Geotextiles by Capillary Flow Test¹

This standard is issued under the fixed designation D 6767; the number immediately following the designation indicates the year of original adoption or, in the case of revision, the year of last revision. A number in parentheses indicates the year of last reapproval. A superscript epsilon (ϵ) indicates an editorial change since the last revision or reapproval.

1. Scope

1.1 This test method covers the determination of the pore size distribution of geotextile filters with pore sizes ranging from 1 to 500 μm .

NOTE 1—The accuracy of this procedure has been verified up to a maximum pore size of 200 μm . Above this value accuracy has been found to be equipment dependent and should be verified by the user through checks on materials with known opening sizes.

1.2 The test method measures the entire pore size distribution in terms of a surface analysis of specified pore sizes in a geotextile, defined in terms of the limiting diameters.

1.3 The analyst should be aware that adequate collaborative data for bias statements as required by Practice D 2777 is not provided. See the precision and bias section for details.

1.4 *This standard may involve hazardous materials, operations, and equipment. This standard does not purport to address all of the safety concerns, if any, associated with its use. It is the responsibility of the user of this standard to establish appropriate safety and health practices and determine the applicability of regulatory limitations prior to use.*

2. Referenced Documents

- 2.1 *ASTM Standards:*
D 1129 Definition of Terms Relating to Water²
D 2777 Practice for Determination of Precision and Bias of Applicable Methods of Committee D-19 on Water²
D 4354 Practice for Sampling Geosynthetics (for Testing)³
D 4439 Terminology Relating to Geosynthetics³
E 128 Test Method for Maximum Pore Diameter and Permeability of Rigid Porous Filters for Laboratory Use⁴
F 316 Pore Size Characteristics of Membrane Filter by Bubble Point and Mean Flow Pore Test⁴

3. Terminology

3.1 *Definitions*—For definitions of other terms used in these test methods, refer to Definitions D 4439 and D 1129.

¹ This test method is under the jurisdiction of ASTM Committee D35 on Geosynthetics and is the direct responsibility of Subcommittee D35.03 on Hydraulic Properties.

Current edition approved Feb 10, 2002. Published August 2002.

² *Annual Book of ASTM Standards*, Vol 11.01.

³ *Annual Book of ASTM Standards*, Vol 04.02.

⁴ *Annual Book of ASTM Standards*, Vol 14.02.

3.2 Definitions of Terms Specific to This Standard:

3.2.1 *bubble point pore size (O_{08})*, n —the largest effective pore diameter detected by the sudden increase of flow rate at the beginning of the wet test.

3.2.2 *pore constriction (O)*, n —diameter of a circle having the same area as the smallest section of a given pore.

3.2.3 *pore size (O_i)*, n —capillary equivalent pore diameter for which the percent of total pore diameters i in a given geotextile based on the surface occupied by the pores are smaller than or equal to that diameter.

3.2.4 *pore size distribution (PSD)*, n —percent cumulative distribution of the complete range of pore sizes with in a given geotextile based on the surface occupied by the pores.

3.2.5 *wetting liquid*, n —liquid used to submerge the geotextile specimen prior to beginning the test.

4. Summary of Test Method

4.1 Geotextile filters have discrete pores from one side to the other of the geotextile. The bubble point test is based on the principle that a wetting liquid is held in these continuous pores by capillary attraction and surface tension, and the minimum pressure required to force liquid from these pores is a function of pore diameter.

4.2 A fluid-wet geotextile will pass air when the applied air pressure exceeds the capillary attraction of the fluid in the pore constriction. Smaller pore constrictions will exhibit similar behavior at higher pressures. The relationship between pore size and pressure has been established for water.

4.3 By comparing the gas flow rates of both a wet and dry geotextile at the same pressures, the percentage of the flow passing through the filter pores larger than or equal to the specified size may be calculated from the pressure-size relationship. By increasing pressure in small steps, it is possible to determine the flow contribution of very small pore size increments by difference.

5. Significance and Use

5.1 This test method may be used to:

- 5.1.1 Determine the pore size distribution of a geotextile,
- 5.1.2 Determine the maximum pore size of a geotextile,
- 5.1.3 Determine the mean flow pore size of a geotextile,
- 5.1.4 Determine the effect of processes such as calendaring or needle punching upon the pore size distribution,

5.1.5 Determine the effect of compression upon the pore size distribution of a geotextile, and

5.1.6 Determine the gas flow rate of a geotextile, and thereby its gas flow capability.

5.2 The pore size distribution test is significant not only for indicating pore sizes, but may also indicate a damaged, contaminated, or clogged geotextile.

6. Apparatus⁵

6.1 *Clean Gas Pressure Source*, with regulation (filtered air or nitrogen).

6.2 *Pressure Transducer, U-tube Manometer or Gage*, (or set of gages), covering the necessary pressure range for the pore sizes under study (see Table 1).

NOTE 2—Pressure measurements must be installed immediately upstream (for example, within 5 mm) of the sample holder.

6.3 *Closed Filter Holder*, (see Fig. 1).

NOTE 3—The filter holder should be checked for leaks by placing a geomembrane in the holder and increasing the pressure to 70 kN/m² and holding it for a period of one minute.

6.4 *Metal Punch*, used to cut a suitable size geotextile from the test sheet to fit the test filter holder.

6.5 *Set of Flowmeters*, covering the range from 0 to 100 L/min.

NOTE 4—Four flowmeters with flow rates of 0 to 0.4, 0 to 2.5, 0 to 25, and 0 to 100 L/min, placed in a parallel arrangement to cover the range of flow rates anticipated are recommended for geotextiles. The smallest flow rate that could be measured by the flowmeters is typically reported to be 0.02 L/min. The manufacturer-rated precision of each flowmeter is typically reported to be 0.25 percent of the maximum reading.

6.6 *In-Line Fluid Trap*, to protect the flowmeters from the fluid.

6.7 *Appropriate Fittings, Hose, Connectors, Piping*, to assemble apparatus as shown in Figs. 2 and 3.

6.8 *x-y Recorder*, to assist in graphing results of mean flow pore test.

7. Sampling

7.1 *Lot Sample*—For routine Quality Control testing, divide the product into lots and take the lot sample as directed in Practice D 4354, Section 7 “Procedure B Sampling for Quality Assurance Testing.” For Specification Conformance testing,

⁵ Different equipment is available for obtaining pore size measurements including commercially available equipment from Porous Materials Inc. (PMI) (with special modifications for geotextiles) and Beckman Coulter, Inc. The equipment developers should be contacted for limitation specifically in relation to measuring the larger opening sizes of geotextiles.

TABLE 1 Pressure Ranges Required

Fluid Used	Pore Size Range to be Investigated				Surface Tension dynes/cm at 25°C
	≥ 100 μm	≥ 50 μm	≥ 10 μm	≥ 1 μm	
Water	0 to 2.5 kPa	0 to 7.5 kPa	0 to 25 kPa	0 to 200 kPa	72
Petroleum distillate				0 to 100 kPa	30
Mineral oil				0 to 75 kPa	34.7

sample as directed in Practice D 4354, Section 6 “Procedure A-Sampling for Specification Conformance.”

7.2 *Laboratory Sample*—As a laboratory sample for acceptance testing, take a full width swatch 1 m long from the end of each roll of fabric in the lot sample, after first discarding a minimum of 1 m of fabric from the very outside of the roll.

7.3 *Test Specimens*—Cut five specimens from each swatch in the laboratory sample with each specimen being cut to fit the appropriate sieve pan. Cut the specimens from a single swatch spaced along a diagonal line on the swatch.

8. Specimen Preparation

8.1 Weigh the specimens and then submerge them in distilled water for 1 h and allow to air dry at the standard atmosphere for testing.

9. Wetting Liquids

9.1 *Purity of Reagents*—Reagent grade chemicals shall be used for wetting liquids in all tests. Unless otherwise indicated, it is intended that all reagents shall conform to the specifications of the Committee on Analytical Reagents of the American Chemical Society where such specifications are available.⁶ Other grades may be used provided it is first ascertained that the reagent is of sufficient high purity to permit its use without lessening the accuracy of the determination.

9.2 *Water*, conforming to Specification D 1193, Type IV or higher purity.

9.3 *Denatured Alcohol*.

9.4 *Petroleum Distillate*, with surface tension of 30 dynes/cm at 25°C.

9.5 *Mineral Oil*, such as USP liquid petrolatum heavy, with surface tension of 34.7 dynes/cm at 25°C.

9.6 *1,1,2-trichloro-1,2,2-trifluoroethane (Freon TF®)*, available from commercial chemical supply houses.

9.7 *Clean Gas Pressure Source*, with regulation (filtered air or nitrogen).

NOTE 5—Table 1 lists the nominal surface tension of these liquids at 25°C. There is a potential influence of the liquid on a measurement of pore size, which should be taken into account by users through verification tests on materials with known pore size. Other liquids can be used and several are currently under evaluation

10. Procedure for One Holder (see Fig. 2)

10.1 Place a dry geotextile sample disk in the geotextile holder.

10.2 Close the holder and apply gas pressure in increments.

10.3 Plot gas flow versus gas pressure over the intended range of use.

10.4 Reduce gas pressure and remove the geotextile from the holder.

10.5 Completely wet the geotextile by submerging it in wetting liquids (for example, water) for a period of 30 min. Replace the wet geotextile in the holder, and apply a slight

⁶ Reagent Chemicals, American Chemical Society Specifications, Am. Chemical Soc., Washington, DC. For suggestions on the testing of reagents not listed by the American Chemical Society, see “Reagent Chemicals and Standards,” by Joseph Rosin, D. Van Nostrand Co., Inc., New York, NY, and the “United States Pharmacopeia.”

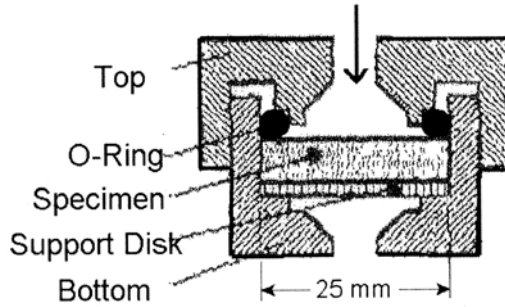

FIG. 1 Closed Filter Holder

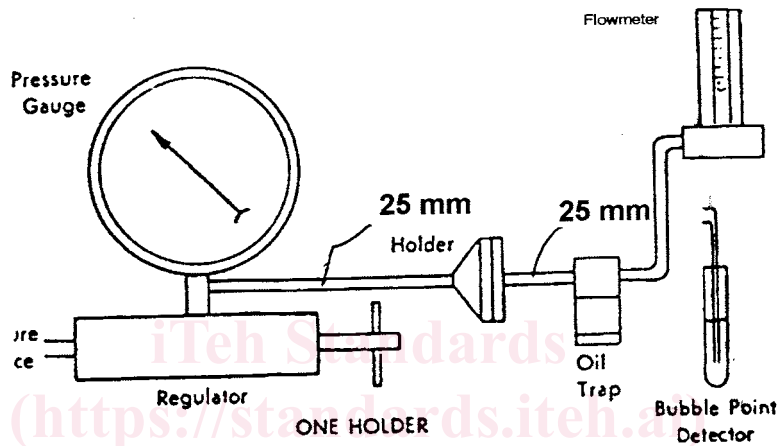

FIG. 2 Setup for One Holder

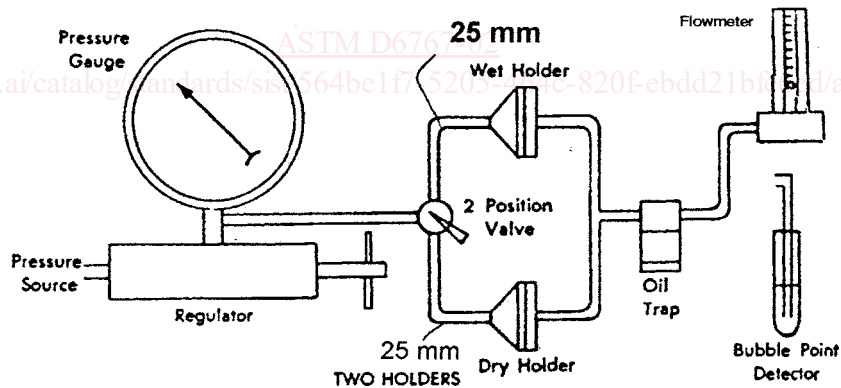

FIG. 3 Setup for Two Holders

pressure, checking to see that a tight seal exists. This pressure must not exceed the bubble point pore size.

10.6 Plot the fluid-wet filter gas flow versus pressure on the same coordinates as for the plot made in accordance with 10.3.

10.7 Reduce the pressure, remove the filter, and clean the holder for the next test.

11. Procedure for Two Holders (see Fig. 3)

11.1 Place a dry geotextile in the holder to be used exclusively for dry geotextiles.

11.2 Wet a geotextile of the same type and lot as the geotextile used in 11.1, in reagent and place it in a holder to be used exclusively for wet geotextiles.