



# SLOVENSKI STANDARD

## SIST EN 300 744 V1.5.1:2005

01-november-2005

---

**Digitalna videoradiodifuzija (DVB) – Struktura okvirov, kodiranje kanalov in modulacija za digitalno prizemno televizijo (DVB-T)**

Digital Video Broadcasting (DVB); Framing structure, channel coding and modulation for digital terrestrial television

**iTeh STANDARD PREVIEW**  
**(standards.iteh.ai)**

[SIST EN 300 744 V1.5.1:2005](https://standards.iteh.ai/catalog/standards/sist/6751d60e-ad92-4fe8-8995-86cafef79679/sist-en-300-744-v1-5-1-2005)

[https://standards.iteh.ai/catalog/standards/sist/6751d60e-ad92-4fe8-8995-](https://standards.iteh.ai/catalog/standards/sist/6751d60e-ad92-4fe8-8995-86cafef79679/sist-en-300-744-v1-5-1-2005)

[86cafef79679/sist-en-300-744-v1-5-1-2005](https://standards.iteh.ai/catalog/standards/sist/6751d60e-ad92-4fe8-8995-86cafef79679/sist-en-300-744-v1-5-1-2005)

**Ta slovenski standard je istoveten z: EN 300 744 Version 1.5.1**

---

**ICS:**

33.170

Televizijska in radijska  
difuzija

Television and radio  
broadcasting

**SIST EN 300 744 V1.5.1:2005**

**en**

**iTeh STANDARD PREVIEW**  
**(standards.iteh.ai)**

[SIST EN 300 744 V1.5.1:2005](https://standards.iteh.ai/catalog/standards/sist/6751d60e-ad92-4fe8-8995-86cafe79679/sist-en-300-744-v1-5-1-2005)

<https://standards.iteh.ai/catalog/standards/sist/6751d60e-ad92-4fe8-8995-86cafe79679/sist-en-300-744-v1-5-1-2005>

# ETSI EN 300 744 V1.5.1 (2004-11)

European Standard (Telecommunications series)

## Digital Video Broadcasting (DVB); Framing structure, channel coding and modulation for digital terrestrial television

European Broadcasting Union (standards.iteh.ai) Union Européenne de Radio-Télévision  
EBU-UER



SIST EN 300 744 V1.5.1

<https://standards.iteh.ai/catalog/standards/sist/6751d60e-ad92-4fe8-8995-86cafe79679/sist-en-300-744-v1-5-1-2005>



---

**Reference**

REN/JTC-DVB-156

---

**Keywords**audio, broadcasting, data, digital, DVB, MPEG,  
terrestrial, TV, video**ETSI**650 Route des Lucioles  
F-06921 Sophia Antipolis Cedex - FRANCE

Tel.: +33 4 92 94 42 00 Fax: +33 4 93 65 47 16

Siret N° 348 623 562 00017 - NAF 742 C  
Association à but non lucratif enregistrée à la  
Sous-Préfecture de Grasse (06) N° 7803/88

**iTeh STANDARD PREVIEW**  
**(standards.iteh.ai)**

SIST EN 300 744 V1.5.1:2005<https://standards.iteh.ai/catalog/standards/sist/6751d60e-ad92-4fe8-8995-86cafe79673d/ETSI-EN-300-744-v1-5-1-2005>**Important notice**

Individual copies of the present document can be downloaded from:

<http://www.etsi.org>

The present document may be made available in more than one electronic version or in print. In any case of existing or perceived difference in contents between such versions, the reference version is the Portable Document Format (PDF). In case of dispute, the reference shall be the printing on ETSI printers of the PDF version kept on a specific network drive within ETSI Secretariat.

Users of the present document should be aware that the document may be subject to revision or change of status. Information on the current status of this and other ETSI documents is available at

<http://portal.etsi.org/tb/status/status.asp>

If you find errors in the present document, please send your comment to one of the following services:

[http://portal.etsi.org/chaicor/ETSI\\_support.asp](http://portal.etsi.org/chaicor/ETSI_support.asp)

---

**Copyright Notification**

No part may be reproduced except as authorized by written permission.  
The copyright and the foregoing restriction extend to reproduction in all media.

© European Telecommunications Standards Institute 2004.

© European Broadcasting Union 2004.

All rights reserved.

**DECT™**, **PLUGTESTS™** and **UMTS™** are Trade Marks of ETSI registered for the benefit of its Members.  
**TIPHON™** and the **TIPHON logo** are Trade Marks currently being registered by ETSI for the benefit of its Members.  
**3GPP™** is a Trade Mark of ETSI registered for the benefit of its Members and of the 3GPP Organizational Partners.

# Contents

Intellectual Property Rights .....	5
Foreword.....	5
1 Scope .....	6
2 References .....	6
3 Definitions, symbols and abbreviations .....	7
3.1 Definitions .....	7
3.2 Symbols.....	7
3.3 Abbreviations .....	8
4 Baseline system .....	9
4.1 General considerations .....	9
4.2 Interfacing .....	10
4.3 Channel coding and modulation.....	11
4.3.1 Transport multiplex adaptation and randomization for energy dispersal.....	11
4.3.2 Outer coding and outer interleaving.....	11
4.3.3 Inner coding .....	14
4.3.4 Inner interleaving.....	14
4.3.4.1 Bit-wise interleaving .....	15
4.3.4.2 Symbol interleaver .....	19
4.3.5 Signal constellations and mapping.....	21
4.4 OFDM frame structure .....	25
4.5 Reference signals.....	27
4.5.1 Functions and derivation.....	27
4.5.2 Definition of reference sequence .....	27
4.5.3 Location of scattered pilot cells.....	28
4.5.4 Location of continual pilot carriers.....	29
4.5.5 Amplitudes of all reference information.....	29
4.6 Transmission Parameter Signalling (TPS) .....	29
4.6.1 Scope of the TPS .....	30
4.6.2 TPS transmission format.....	31
4.6.2.1 Initialization .....	31
4.6.2.2 Synchronization .....	31
4.6.2.3 TPS length indicator.....	31
4.6.2.4 Frame number .....	32
4.6.2.5 Constellation .....	32
4.6.2.6 Hierarchy information.....	32
4.6.2.7 Code rates.....	32
4.6.2.8 Guard Intervals.....	33
4.6.2.9 Transmission mode .....	33
4.6.2.10 Cell identifier .....	34
4.6.2.11 Error protection of TPS.....	34
4.6.3 TPS modulation .....	34
4.7 Number of RS-packets per OFDM super-frame.....	35
4.8 Spectrum characteristics and spectrum mask .....	35
4.8.1 Spectrum characteristics .....	35
4.8.2 Out-of-band spectrum mask (for 8 MHz channels) .....	36
4.8.3 Centre frequency of RF signal (for 8 MHz UHF channels).....	39
<b>Annex A (informative): Simulated system performance for 8 MHz channels .....</b>	<b>40</b>
<b>Annex B (informative): Definition of <math>P_1</math> and <math>F_1</math> .....</b>	<b>42</b>
<b>Annex C (informative): Interleaving example .....</b>	<b>44</b>
<b>Annex D (informative): Guidelines to implementation of the emitted signal.....</b>	<b>45</b>

D.1	Use of the FFT.....	45
D.2	Choice of "baseband" centre frequency .....	46
D.3	Other potential difficulties.....	46
<b>Annex E (normative):</b>	<b>Values for 6 MHz and 7 MHz channels .....</b>	<b>47</b>
<b>Annex F (normative):</b>	<b>Additional features for DVB Handheld terminals (DVB-H) .....</b>	<b>50</b>
F.1	General Considerations .....	50
F.2	Additional features overview .....	50
<b>Annex G (normative):</b>	<b>5 MHz channel bandwidth operation.....</b>	<b>61</b>
History	.....	64

## iTeh STANDARD PREVIEW (standards.iteh.ai)

[SIST EN 300 744 V1.5.1:2005](https://standards.iteh.ai/catalog/standards/sist/6751d60e-ad92-4fe8-8995-86cafef79679/sist-en-300-744-v1-5-1-2005)

<https://standards.iteh.ai/catalog/standards/sist/6751d60e-ad92-4fe8-8995-86cafef79679/sist-en-300-744-v1-5-1-2005>

## Intellectual Property Rights

IPRs essential or potentially essential to the present document may have been declared to ETSI. The information pertaining to these essential IPRs, if any, is publicly available for **ETSI members and non-members**, and can be found in ETSI SR 000 314: "*Intellectual Property Rights (IPRs); Essential, or potentially Essential, IPRs notified to ETSI in respect of ETSI standards*", which is available from the ETSI Secretariat. Latest updates are available on the ETSI Web server (<http://webapp.etsi.org/IPR/home.asp>).

Pursuant to the ETSI IPR Policy, no investigation, including IPR searches, has been carried out by ETSI. No guarantee can be given as to the existence of other IPRs not referenced in ETSI SR 000 314 (or the updates on the ETSI Web server) which are, or may be, or may become, essential to the present document.

## Foreword

This European Standard (Telecommunications series) has been produced by Joint Technical Committee (JTC) Broadcast of the European Broadcasting Union (EBU), Comité Européen de Normalisation ELECtrotechnique (CENELEC) and the European Telecommunications Standards Institute (ETSI).

NOTE: The EBU/ETSI JTC Broadcast was established in 1990 to co-ordinate the drafting of standards in the specific field of broadcasting and related fields. Since 1995 the JTC Broadcast became a tripartite body by including in the Memorandum of Understanding also CENELEC, which is responsible for the standardization of radio and television receivers. The EBU is a professional association of broadcasting organizations whose work includes the co-ordination of its members' activities in the technical, legal, programme-making and programme-exchange domains. The EBU has active members in about 60 countries in the European broadcasting area; its headquarters is in Geneva.

European Broadcasting Union  
 CH-1218 GRAND SACONNEX (Geneva)  
 Switzerland  
 Tel: +41 22 717 21 11  
 Fax: +41 22 717 24 81

SIST EN 300 744 V1.5.1:2005  
[standards.iteh.ai/catalog/standards/sist/6751d60e-ad92-4fe8-8995-86cafe79679/sist-en-300-744-v1-5-1-2005](http://standards.iteh.ai/catalog/standards/sist/6751d60e-ad92-4fe8-8995-86cafe79679/sist-en-300-744-v1-5-1-2005)

Founded in September 1993, the DVB Project is a market-led consortium of public and private sector organizations in the television industry. Its aim is to establish the framework for the introduction of MPEG-2 based digital television services. Now comprising over 200 organizations from more than 25 countries around the world, DVB fosters market-led systems, which meet the real needs, and economic circumstances, of the consumer electronics and the broadcast industry.

### National transposition dates

Date of adoption of this EN:	29 October 2004
Date of latest announcement of this EN (doa):	31 January 2005
Date of latest publication of new National Standard or endorsement of this EN (dop/e):	31 July 2005
Date of withdrawal of any conflicting National Standard (dow):	31 July 2005

---

# 1 Scope

The present document describes a baseline transmission system for digital terrestrial TeleVision (TV) broadcasting. It specifies the channel coding/modulation system intended for digital multi-programme LDTV/SDTV/EDTV/HDTV terrestrial services.

The scope is as follows:

- it gives a general description of the Baseline System for digital terrestrial TV;
- it identifies the global performance requirements and features of the Baseline System, in order to meet the service quality targets;
- it specifies the digitally modulated signal in order to allow compatibility between pieces of equipment developed by different manufacturers. This is achieved by describing in detail the signal processing at the modulator side, while the processing at the receiver side is left open to different implementation solutions. However, it is necessary in this text to refer to certain aspects of reception.

In order to address Handheld terminals (DVB-H) in annexes are provided:

- an additional 4K Mode offering supplementary options for network planning (annex F);
- an optional in-depth inner interleaver, to mitigate the effects of the high level of man-made noise affecting the reception of DVB-H services (annex F);
- an extension of the Transmission Parameter Signalling (TPS) information for signalling DVB-H Services (annex F);
- the transmission parameters to operate the transmission system in 5 MHz channel bandwidth, even outside of the traditional broadcasting bands (annex G).

iTeh STANDARD PREVIEW  
(standards.iteh.ai)

SIST EN 300 744 V1.5.1:2005

[https://standards.iteh.ai/catalog/standards/sist/6751d60e-ad92-4fe8-8995-](https://standards.iteh.ai/catalog/standards/sist/6751d60e-ad92-4fe8-8995-86cafef79679/sist-en-300-744-v1-5-1-2005)

[86cafef79679/sist-en-300-744-v1-5-1-2005](https://standards.iteh.ai/catalog/standards/sist/6751d60e-ad92-4fe8-8995-86cafef79679/sist-en-300-744-v1-5-1-2005)

---

# 2 References

The following documents contain provisions which, through reference in this text, constitute provisions of the present document.

- References are either specific (identified by date of publication and/or edition number or version number) or non-specific.
- For a specific reference, subsequent revisions do not apply.
- For a non-specific reference, the latest version applies.

Referenced documents which are not found to be publicly available in the expected location might be found at <http://docbox.etsi.org/Reference>.

- [1] ISO/IEC 13818 (Parts 1 to 3): "Information technology - Generic coding of moving pictures and associated audio information".
- [2] ETSI EN 300 421: "Digital Video Broadcasting (DVB); Framing structure, channel coding and modulation for 11/12 GHz satellite services".
- [3] ETSI EN 300 429: "Digital Video Broadcasting (DVB); Framing structure, channel coding and modulation for cable systems".
- [4] ETSI EN 300 468: "Digital Video Broadcasting (DVB); Specification for Service Information (SI) in DVB systems".



## 3 Definitions, symbols and abbreviations

### 3.1 Definitions

For the purposes of the present document, the following definition applies:

**constraint length:** number of delay elements +1 in the convolutional coder

### 3.2 Symbols

For the purposes of the present document, the following symbols apply:

$A(e)$	output vector from inner bit interleaver $e$
$a_{e,w}$	bit number $w$ of inner bit interleaver output stream $e$
$\alpha$	constellation ratio which determines the QAM constellation for the modulation for hierarchical transmission
$B(e)$	input vector to inner bit interleaver $e$
$b_{e,w}$	bit number $w$ of inner bit interleaver input stream $e$
$b_{e,d_0}$	output bit number $d_0$ of demultiplexed bit stream number $e$ of the inner interleaver demultiplexer
$b_i$	bit number $i$ of the cell identifier
$c_{m,l,k}$	complex cell for frame $m$ in OFDM symbol $l$ at carrier $k$
$C'_k$	Complex modulation for a reference signal at carrier $k$
$C'_{l,k}$	Complex modulation for a TPS signal at carrier $k$ in symbol $l$
$C/N$	Carrier-to-Noise ratio
$\Delta$	time duration of the guard interval
$d_{\text{free}}$	convolutional code free distance
$f_c$	centre frequency of the emitted signal
$G_1, G_2$	convolutional code Generator polynomials
$g(x)$	Reed-Solomon code generator polynomial
$h(x)$	BCH code generator polynomial
$H(q)$	inner symbol interleaver permutation
$H_e(w)$	inner bit interleaver permutation
$i$	priority stream index
$I$	Interleaving depth of the outer convolutional interleaver
$I_0, I_1, I_2, I_3, I_4, I_5$	inner Interleavers
$j$	branch index of the outer interleaver
$k$	carrier number index in each OFDM symbol
$K$	number of active carriers in the OFDM symbol
$K_{\text{min}}, K_{\text{max}}$	carrier number of the lower and largest active carrier respectively in the OFDM signal
$l$	OFDM symbol number index in an OFDM frame
$m$	OFDM frame number index
$m'$	OFDM super-frame number index
$M$	convolutional interleaver branch depth for $j = 1, M = N/I$
$n$	transport stream sync byte number
$N$	length of error protected packet in bytes
$N_{\text{max}}$	inner symbol interleaver block size
$p$	scattered pilot insertion index
$p(x)$	RS code field generator polynomial
$P_k(f)$	Power spectral density for carrier $k$
$P(n)$	interleaving Pattern of the inner symbol interleaver
$r_i$	code rate for priority level $i$
$s_i$	TPS bit index
$t$	number of bytes which can be corrected by the Reed-Solomon decoder
$T$	elementary Time period
$T_S$	duration of an OFDM symbol

$T_F$	Time duration of a frame
$T_U$	Time duration of the useful (orthogonal) part of a symbol, without the guard interval
$u$	bit numbering index
$v$	number of bits per modulation symbol
$w_k$	value of reference PRBS sequence applicable to carrier $k$
$x_{di}$	input bit number $d_i$ to the inner interleaver demultiplexer
$x'_{di}$	high priority input bit number $d_i$ to the inner interleaver demultiplexer
$x''_{di}$	low priority input bit number $d_i$ to the inner interleaver demultiplexer
$Y$	output vector from inner symbol interleaver
$Y'$	intermediate vector of inner symbol interleaver
$y_q$	bit number $q$ of output from inner symbol interleaver
$y'_q$	bit number $q$ of intermediate vector of inner symbol interleaver
$z$	complex modulation symbol
*	complex conjugate

### 3.3 Abbreviations

For the purposes of the present document, the following abbreviations apply:

ACI	Adjacent Channel Interference
BCH	Bose - Chaudhuri - Hocquenghem code
BER	Bit Error Ratio
CCI	Co-Channel Interference
DBPSK	Differential Binary Phase Shift Keying
DFT	Discrete Fourier Transform
DVB	Digital Video Broadcasting
DVB-H	DVB-Handheld
DVB-T	DVB-Terrestrial
EDTV	Enhanced Definition TeleVision
FFT	Fast Fourier Transform
FIFO	First-In, First-Out shift register
HDTV	High Definition TeleVision
HP	High Priority bit stream
IFFT	Inverse Fast Fourier Transform
LDTV	Limited Definition TeleVision
LP	Low Priority bit stream
MPEG	Moving Picture Experts Group
MSB	Most Significant Bit
MUX	MUltipleX
NICAM	Near-Instantaneous Companded Audio Multiplex
OFDM	Orthogonal Frequency Division Multiplexing
PAL	Phase Alternating Line
PRBS	Pseudo-Random Binary Sequence
QAM	Quadrature Amplitude Modulation
QEF	Quasi Error Free
QPSK	Quaternary Phase Shift Keying
RF	Radio Frequency
RS	Reed-Solomon
SDTV	Standard Definition TeleVision
SECAM	Système Séquentiel Couleur A Mémoire
SFN	Single Frequency Network
TPS	Transmission Parameter Signalling
TV	TeleVision
UHF	Ultra-High Frequency
VHF	Very-High Frequency

## 4 Baseline system

### 4.1 General considerations

The system is defined as the functional block of equipment performing the adaptation of the baseband TV signals from the output of the MPEG-2 transport multiplexer, to the terrestrial channel characteristics. The following processes shall be applied to the data stream (see [1]):

- transport multiplex adaptation and randomization for energy dispersal;
- outer coding (i.e. Reed-Solomon code);
- outer interleaving (i.e. convolutional interleaving);
- inner coding (i.e. punctured convolutional code);
- inner interleaving (either native or in-depth);
- mapping and modulation;
- Orthogonal Frequency Division Multiplexing (OFDM) transmission.

The system is directly compatible with MPEG-2 coded TV signals ISO/IEC 13818 [1].

Since the system is being designed for digital terrestrial television services to operate within the existing VHF and UHF (see note) spectrum allocation for analogue transmissions, it is required that the System provides sufficient protection against high levels of Co-Channel Interference (CCI) and Adjacent Channel Interference (ACI) emanating from existing PAL/SECAM/NTSC services. It is also a requirement that the System allows the maximum spectrum efficiency when used within the VHF and UHF bands; this requirement can be achieved by utilizing Single Frequency Network (SFN) operation.

NOTE: The OFDM system in the present document is specified for 8 MHz, 7 MHz and 6 MHz channel spacing. The basic specification is the same for the three bandwidths except for the parameter *elementary period T*, which is unique for the respective bandwidths. From an implementation point of view the elementary period *T* can normally be seen as the inverse of the nominal system clock rate. By adjusting the system clock rate the bandwidth and bit rate are modified accordingly. The parameters to operate the transmission system in 5 MHz channel, outside the traditional broadcast bands, are given in the annex G.

To achieve these requirements an OFDM system with concatenated error correcting coding is being specified. To maximize commonality with the Satellite baseline specification (see EN 300 421 [2]) and Cable baseline specifications (see EN 300 429 [3]) the outer coding and outer interleaving are common, and the inner coding is common with the Satellite baseline specification. To allow optimal trade off between network topology and frequency efficiency, a flexible guard interval is specified. This will enable the system to support different network configurations, such as large area SFN and single transmitter, while keeping maximum frequency efficiency.

Two modes of operation, a "2K mode" and an "8K mode", are defined for DVB-T and DVB-H transmissions. The "2K mode" is suitable for single transmitter operation and for small SFN networks with limited transmitter distances. The "8K mode" can be used both for single transmitter operation and for small and large SFN networks.

Exclusively for use in DVB-H systems, a third transmission mode the "4K mode" is defined in annex F, addressing the specific needs of Handheld terminals. The "4K mode" aims to offer an additional trade-off between transmission cell size and mobile reception capabilities, providing an additional degree of flexibility for DVB-H network planning.

The system allows different levels of QAM modulation and different inner code rates to be used to trade bit rate versus ruggedness. The system also allows two level hierarchical channel coding and modulation, including uniform and multi-resolution constellation. In this case the functional block diagram of the system shall be expanded to include the modules shown dashed in figure 1. Two independent MPEG transport streams, referred to as the high-priority and the low-priority stream, are mapped onto the signal constellation by the Mapper and the Modulator which therefore has a corresponding number of inputs.

To guarantee that the signals emitted by such hierarchical systems may be received by a simple receiver the hierarchical nature is restricted to hierarchical channel coding and modulation without the use of hierarchical source coding.

A programme service can thus be "simulcast" as a low-bit-rate, rugged version and another version of higher bit rate and lesser ruggedness. Alternatively, entirely different programmes can be transmitted on the separate streams with different ruggedness. In either case, the receiver requires only one set of the inverse elements: inner de-interleaver, inner decoder, outer de-interleaver, outer decoder and multiplex adaptation. The only additional requirement thus placed on the receiver is the ability for the demodulator/de-mapper to produce one stream selected from those mapped at the sending end.

The price for this receiver economy is that reception can not switch from one layer to another (e.g. to select the more rugged layer in the event of reception becoming degraded) while continuously decoding and presenting pictures and sound. A pause is necessary (e.g. video freeze frame for approximately 0,5 seconds, audio interruption for approximately 0,2 seconds) while the inner decoder and the various source decoders are suitably reconfigured and reacquire lock.

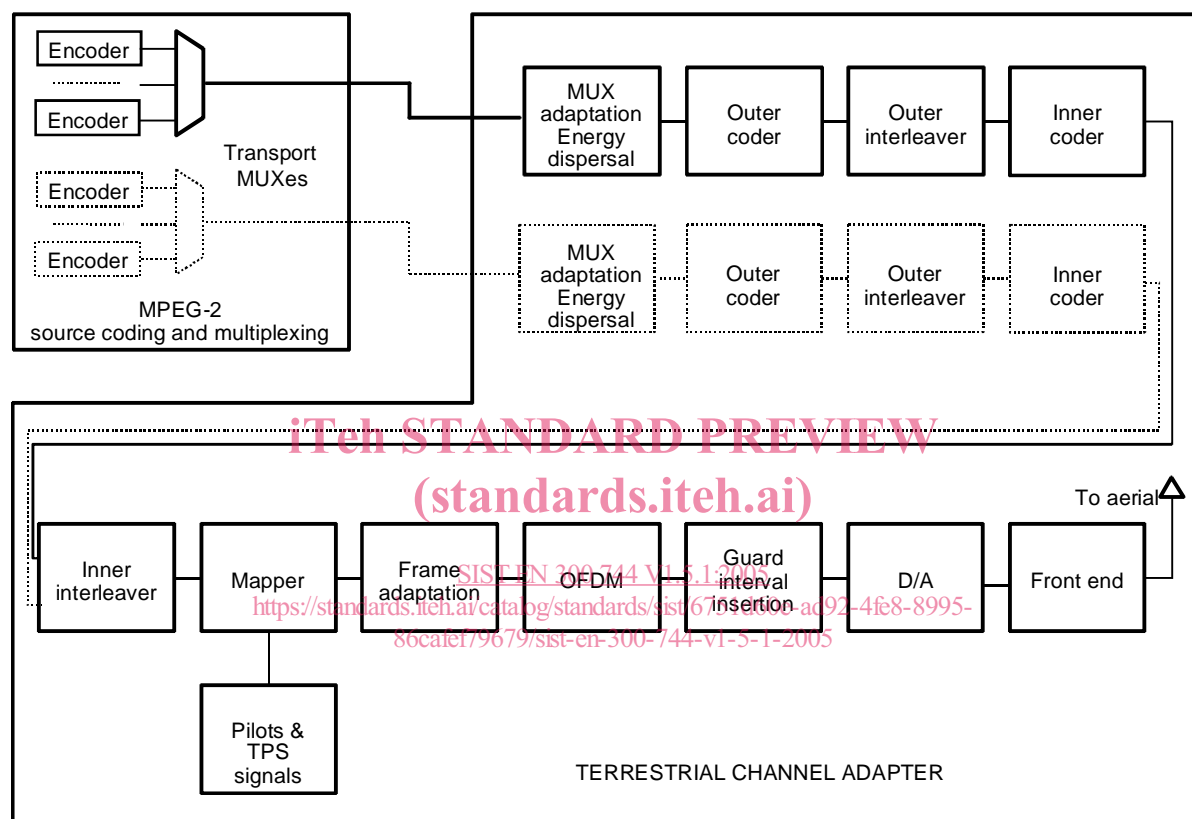

Figure 1: Functional block diagram of the System

## 4.2 Interfacing

The Baseline System as defined in the present document is delimited by the following interfaces:

Table 1: Interfaces for the Baseline System

Location	Interface	Interface type	Connection
Transmit Station	Input	MPEG-2 transport stream(s) multiplex	from MPEG-2 multiplexer
	Output	RF signal	to aerial
Receive Installation	Input	RF	from aerial
	Output	MPEG-2 transport stream multiplex	to MPEG-2 demultiplexer

## 4.3 Channel coding and modulation

### 4.3.1 Transport multiplex adaptation and randomization for energy dispersal

The System input stream shall be organized in fixed length packets (see figure 3), following the MPEG-2 transport multiplexer. The total packet length of the MPEG-2 transport multiplex (MUX) packet is 188 bytes. This includes 1 sync-word byte (i.e.  $47_{\text{HEX}}$ ). The processing order at the transmitting side shall always start from the MSB (i.e. "0") of the sync-word byte (i.e. 01 000 111). In order to ensure adequate binary transitions, the data of the input MPEG-2 multiplex shall be randomized in accordance with the configurations depicted in figure 2.

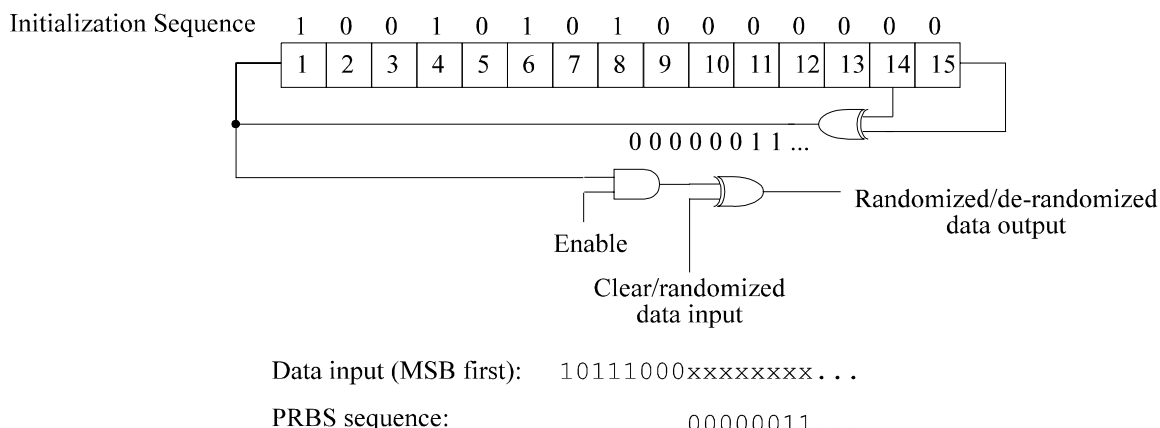

Figure 2: Scrambler/descrambler schematic diagram

The polynomial for the Pseudo Random Binary Sequence (PRBS) generator shall be (see note):

$$1 + X^{14} + X^{15}$$

<https://standards.iteh.ai/catalog/standards/sist/6751d60e-ad92-4fe8-8995-86cafe79679/sist-en-300-744-v1-5-1-2005>

NOTE: The polynomial description given here is in the form taken from the Satellite baseline specification EN 300 421 [2]. Elsewhere, in both the Satellite baseline specification and in the present document, a different polynomial notation is used which conforms with the standard textbook of Peterson and Weldon (Error correcting codes, second edition, MIT Press, 1972).

Loading of the sequence "100101010000000" into the PRBS registers, as indicated in figure 2, shall be initiated at the start of every eight transport packets. To provide an initialization signal for the descrambler, the MPEG-2 sync byte of the first transport packet in a group of eight packets is bit-wise inverted from  $47_{\text{HEX}}$  (SYNC) to  $B8_{\text{HEX}}$  (SYNC). This process is referred to as "transport multiplex adaptation" (see figure 3b).

The first bit at the output of the PRBS generator shall be applied to the first bit (i.e. MSB) of the first byte following the inverted MPEG-2 sync byte (i.e.  $B8_{\text{HEX}}$ ). To aid other synchronization functions, during the MPEG-2 sync bytes of the subsequent 7 transport packets, the PRBS generation shall continue, but its output shall be disabled, leaving these bytes unrandomized. Thus, the period of the PRBS sequence shall be 1 503 bytes.

The randomization process shall be active also when the modulator input bit-stream is non-existent, or when it is non-compliant with the MPEG-2 transport stream format (i.e. 1 sync byte + 187 packet bytes).

### 4.3.2 Outer coding and outer interleaving

The outer coding and interleaving shall be performed on the input packet structure (see figure 3a).

Reed-Solomon RS (204,188, t = 8) shortened code (see note 1), derived from the original systematic RS (255,239, t = 8) code, shall be applied to each randomized transport packet (188 byte) of figure 3b to generate an error protected packet (see figure 3c). Reed-Solomon coding shall also be applied to the packet sync byte, either non-inverted (i.e.  $47_{\text{HEX}}$ ) or inverted (i.e.  $B8_{\text{HEX}}$ ).

NOTE 1: The Reed-Solomon code has length 204 bytes, dimension 188 bytes and allows to correct up to 8 random erroneous bytes in a received word of 204 bytes.

Code Generator Polynomial:  $g(x) = (x+\lambda^0)(x+\lambda^1)(x+\lambda^2)\dots(x+\lambda^{15})$ , where  $\lambda = 02_{\text{HEX}}$

Field Generator Polynomial:  $p(x) = x^8 + x^4 + x^3 + x^2 + 1$

The shortened Reed-Solomon code may be implemented by adding 51 bytes, all set to zero, before the information bytes at the input of an RS (255,239, t = 8) encoder. After the RS coding procedure these null bytes shall be discarded, leading to a RS code word of  $N = 204$  bytes.

Following the conceptual scheme of figure 4, convolutional byte-wise interleaving with depth  $I = 12$  shall be applied to the error protected packets (see figure 3c). This results in the interleaved data structure (see figure 3d).

The convolutional interleaving process shall be based on the Forney approach which is compatible with the Ramsey type III approach, with  $I = 12$ . The interleaved data bytes shall be composed of error protected packets and shall be delimited by inverted or non-inverted MPEG-2 sync bytes (preserving the periodicity of 204 bytes).

The interleaver may be composed of  $I = 12$  branches, cyclically connected to the input byte-stream by the input switch. Each branch  $j$  shall be a First-In, First-Out (FIFO) shift register, with depth  $j \times M$  cells where  $M = 17 = N/I$ ,  $N = 204$ . The cells of the FIFO shall contain 1 byte, and the input and output switches shall be synchronized.

For synchronization purposes, the SYNC bytes and the  $\overline{\text{SYNC}}$  bytes shall always be routed in the branch "0" of the interleaver (corresponding to a null delay).

NOTE 2: The deinterleaver is similar in principle, to the interleaver, but the branch indices are reversed (i.e.  $j = 0$  corresponds to the largest delay). The deinterleaver synchronization can be carried out by routing the first recognized sync (SYNC or  $\overline{\text{SYNC}}$ ) byte in the "0" branch.

ITh STANDARD PREVIEW  
(standards.iteh.ai)

[SIST EN 300 744 V1.5.1:2005](https://standards.iteh.ai/catalog/standards/sist/6751d60e-ad92-4fe8-8995-86cafef79679/sist-en-300-744-v1-5-1-2005)

<https://standards.iteh.ai/catalog/standards/sist/6751d60e-ad92-4fe8-8995-86cafef79679/sist-en-300-744-v1-5-1-2005>

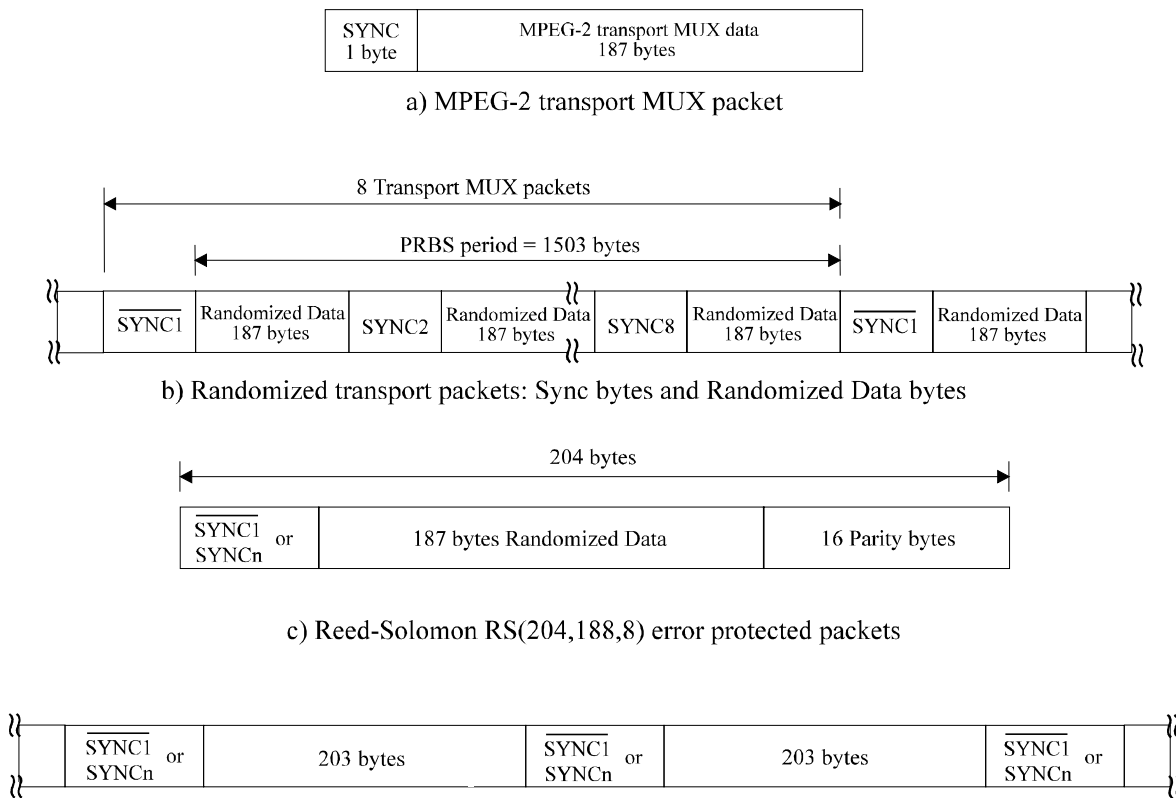

d) Data structure after outer interleaving; interleaving depth I = 12 bytes

(standards.iteh.ai)

SYNC1: Non randomized complemented sync byte  
 SYNCn: Non randomized sync byte, n = 2, 3, ..., 8

Figure 3: Steps in the process of adaptation, energy dispersal, outer coding and interleaving

SYNC1 is the non randomized complemented sync byte and SYNCn is the non randomized sync byte, n = 2, 3, ..., 8.

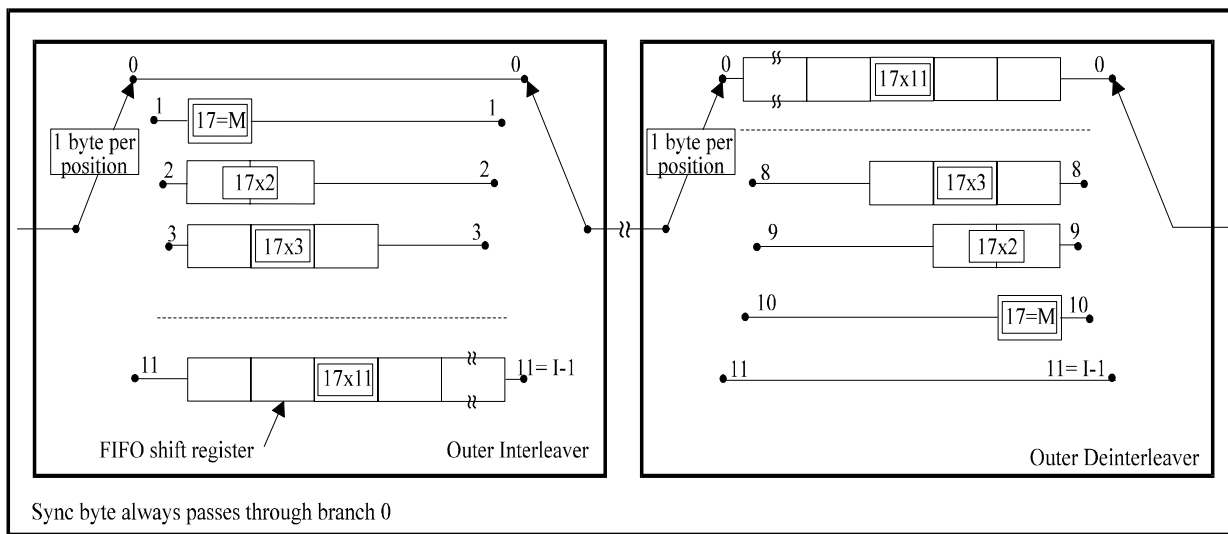

Figure 4: Conceptual diagram of the outer interleaver and deinterleaver