



Designation: D 2168 – 02

Standard Test Methods for Calibration of Laboratory Mechanical-Rammer Soil Compactors¹

This standard is issued under the fixed designation D 2168; the number immediately following the designation indicates the year of original adoption or, in the case of revision, the year of last revision. A number in parentheses indicates the year of last reapproval. A superscript epsilon (ϵ) indicates an editorial change since the last revision or reapproval.

1. Scope *

1.1 These test methods for the calibration of mechanical soil compactors are for use in checking and adjusting mechanical devices used in laboratory compacting of soil and soil-aggregate in accordance with Test Methods D 698, D 1557 and other methods of a similar nature which might specify this method. Calibration for use with one method does not qualify the equipment for use with another method.

1.2 The weight of the mechanical rammer is adjusted as described in 5.4 and 6.5 in order to provide that the mechanical compactor will produce the same result as the manual compactor.

1.3 Two alternative procedures are provided as follows:

	Section
Test Method A Calibration based on the compaction of a selected soil sample	5
Test Method B Calibration based on the deformation of a standard lead cylinder	6

1.4 If a mechanical compactor is calibrated in accordance with the requirements of either Test Method A or Test Method B, it is not necessary for it to meet the requirements of the other method.

1.5 The values stated in inch-pound units are to be regarded as the standard. The values given in parentheses are for information only.

1.6 *This standard does not purport to address all of the safety concerns, if any, associated with its use. It is the responsibility of the user of this standard to establish appropriate safety and health practices and determine the applicability of regulatory limitations prior to use.*

2. Referenced Documents

2.1 ASTM Standards:

D 653 Terminology Relating to Soil, Rock, and Contained Fluids²

D 698 Test Method for Laboratory Compaction Characteristics of Soil Using Standard Effort (12 400 ft-lbf/ft³ (600 kn-m/m³))²

¹ These test methods are under the jurisdiction of ASTM Committee D18 on Soil and Rock and are the direct responsibility of Subcommittee D 18.03 on Texture, Plasticity, and Density Characteristics of Soils.

Current edition approved July 10, 2002. Published September 2002. Originally published as D 2168 – 90. Last previous edition D 2168 – 90(1996).

² Annual Book of ASTM Standards, Vol 04.08.

D 1557 Test Method for Laboratory Compaction Characteristics of Soil Using Modified Effort (56 000 ft-lbf/ft³ (2700 kn-m/m³))²

D 2487 Classification of Soils for Engineering Purposes (Unified Soil Classification System)²

D 3740 Practice for Agencies Engaged in the Testing and/or Inspection of Soil and Rock as Used Engineering Design and Construction²

E 11 Specification for Wire-Cloth Sieves for Testing Purposes³

E 145 Specification for Gravity-Convection and Forced-Ventilation Ovens⁴

3. Significance and Use

3.1 Mechanical compactors are commonly used to replace the hand compactors required for Test Methods D 698 and D 1557 in cases where it is necessary to increase production.

3.2 The design of mechanical compactors is such that it is necessary to have a calibration process that goes beyond determining the mass and drop of the hammer.

NOTE 1—The quality of the result produced by this standard is dependent on the competence of the personnel performing it, and the suitability of the equipment and facilities used. Agencies that meet the criteria in Practice D 3740 are generally considered capable of competent and objective testing/sampling/inspection/and the like. Users of this standard are cautioned that compliance with Practice D 3740 does not in itself assure reliable results. Reliable results depend on many factors; Practice D 3740 provides a means of evaluating some of those factors.

4. Apparatus

4.1 For Test Method A, in addition to the apparatus requirements specified in Test Methods D 698 and D 1557, the following is required:

4.1.1 *Drying Oven*—Thermostatically controlled oven, preferably of the forced-draft type, meeting the requirements for Specification E 145 and capable of maintaining a uniform temperature of 140 ± 5°F (60 ± 12°C) throughout the drying chamber.

4.2 For Test Method B, in addition to the apparatus requirements specified in Test Methods D 698 and D 1557, the following are required:

³ Annual Book of ASTM Standards, Vol 14.02.

⁴ Annual Book of ASTM Standards, Vol 14.04.

*A Summary of Changes section appears at the end of this standard.

ASTM D 2168 – 02

4.2.1 *Lead Deformation Apparatus*—A lead deformation apparatus consisting of an anvil, guide collar, and striking pin, as shown in Fig. 1.

4.2.2 *Micrometer*—A 1-in. or 25-mm outside micrometer caliper reading to 0.001 in. or 0.02 mm, for determining the length of the lead cylinders. As an alternative, a dial comparator of equal accuracy may be used to determine either the length of the lead cylinder, or of the complete lead deformation

apparatus assembly. In order to measure the complete assembly, a dial comparator with a minimum opening of 2 in. (51 mm) and a travel of 1 in. (25 mm) is required (see Fig. 2).

NOTE 2—The use of vernier calipers is not recommended since they can produce erroneous readings if not zeroed correctly or if the vernier caliper is not of high quality.

4.2.3 *Guide Sleeve Pedestal*—A guide sleeve pedestal for

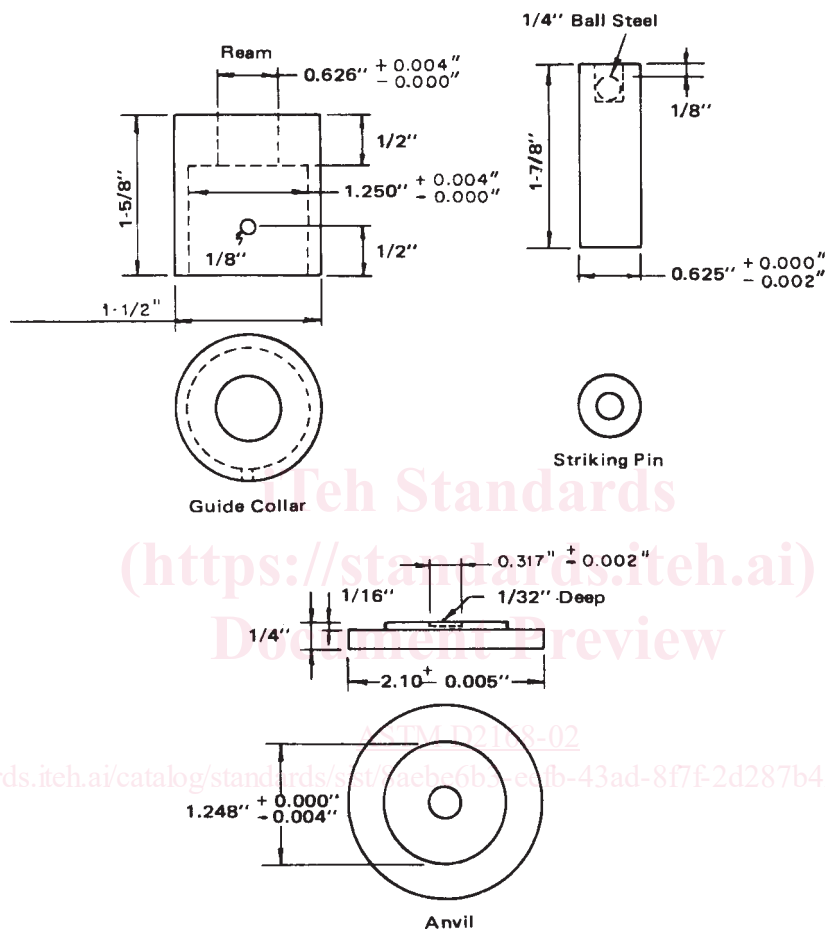

<https://standards.iteh.ai/catalog/standards/sist/6a6be6b3-ec1b-43ad-8f7f-2d287b4208e3/astm-d2168-02>

in.	mm
2.10	53.34
1 7/8	48
1 5/8	41
1 1/2	38
1.250	31.75
1.248	31.70
0.626	15.90
0.625	15.88
1/2	13
0.317	8.05
1/4	6.4
1/8	3.2
1/16	1.6
1/32	0.79
0.005	0.13
0.004	0.10
0.002	0.05
0.001	0.02

NOTE 1—Inside dimension of guide collar should slip easily over raised section of anvil without excessive free play. Anvil should slip easily inside guide sleeve pedestal without excessive free play.

FIG. 1 Lead Deformation Apparatus

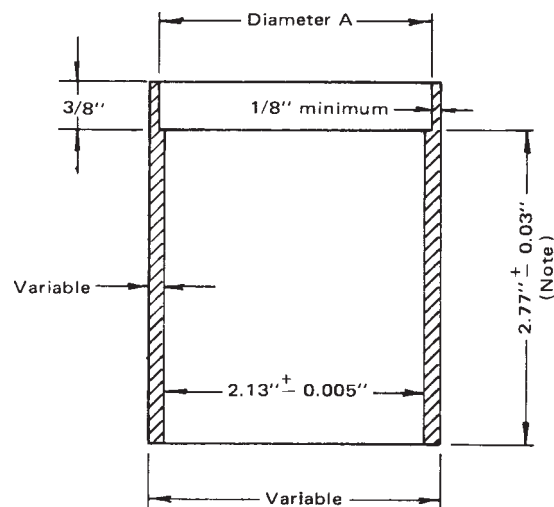
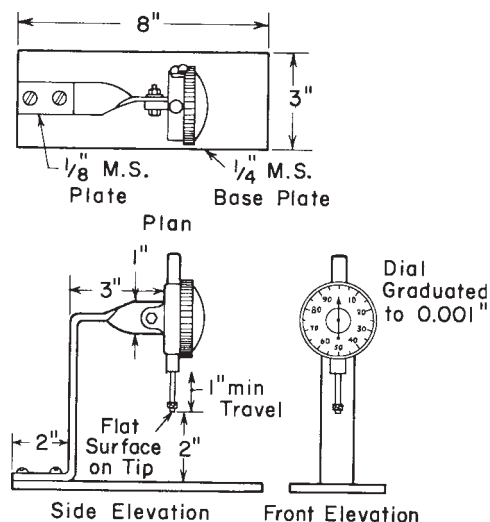

in.	mm
8	203
3	76
2	51
1	25
1/4	6.4
1/8	3.2
0.001	0.02

in.	mm
2.77	70.4
2.13	54.10
3/8	10
1/8	3.2
0.03	0.8
0.005	0.13

FIG. 2 Dial Comparator

FIG. 3 Guide Sleeve Pedestal

use with guide sleeves used to control the drop of the manual rammers in Test Methods D 698 and D 1557 (see Fig. 3).

4.2.4 *Test Cylinders*—A supply of commercially pure lead test cylinders having individual weights such that the lightest cylinder is within 0.06 g of the heaviest, each having a length of 0.675 ± 0.005 in. (17.1 ± 0.1 mm) and a diameter of 0.310 ± 0.002 in. (7.87 ± 0.05 mm).⁵ A minimum of ten test cylinders is required for the calibration of one mechanical compactor. However, depending on circumstances, as many as 100 test cylinders may be required.

5. Procedure—Test Method A

5.1 Thoroughly inspect the mechanical and manual compactors for evidence of wear, malfunction, and need of servicing and adjustment. Clean, adjust, and lubricate the compactors so as to meet all requirements of the manufacturer, and the applicable method under which they will be used and for which the mechanical compactor is to be calibrated. Operate the compactor for a minimum of 25 drops to cause friction in the parts to become constant, allowing the rammer to fall on soil or other soft material.

NOTE 3—In order to provide satisfactory results, mechanical compactors must be in excellent working condition. Improper operation of the raising and release mechanisms can introduce serious errors.

5.2 Obtain approximately 50 lb (23 kg) of soil classified as CL in accordance with Classification D 2487. If excessive moisture is present, dry the soil until it becomes friable. Drying

NOTE 1—This dimension must be equal to the height of the lead deformation apparatus when assembled with the lead cylinder in place, within a tolerance of ± 0.01 in. (± 0.25 mm).

NOTE 2—Diameter A is such that guide sleeve of rammer fits easily into recess without free play.

may be in air or by use of a drying apparatus such that the temperature of the sample does not exceed 140°F (60°C). Pass the soil through a No. 4 (4.75-mm) sieve conforming to the requirements of Specification E 11. Discard any material remaining on the sieve, and thoroughly blend the material passing the sieve until it is uniform. The material shall then be prepared for compaction in accordance with either Methods D 698 or D 1557 as appropriate for the mechanical compactor being calibrated.

NOTE 4—The amount of soil used will vary greatly depending on the number of water content unit mass determinations required.

5.3 Using the soil prepared in accordance with 5.2, determine optimum moisture and maximum dry unit weight by Method A of either Test Methods D 698 or D 1557 or whichever method is appropriate for the mechanical compactor being calibrated. Prepare one curve using the mechanical compactor and another using the manual compactor. Record the values of γ_{max} , the maximum dry unit weight obtained with the manual compactor, and γ'_{max} , the maximum dry unit weight obtained with the mechanical compactor.

5.4 Determine W , the percentage difference of maximum dry unit weight values for a single set of data (see Section 7). If the absolute value of W is equal to or less than 2.0, the mechanical compactor is satisfactory for immediate use. If the absolute value of W is greater than 2.0, then obtain two additional sets of data. Use the same soil sample, prepared in accordance with 5.2, that was used previously. Determine W ,

⁵ Lead test cylinders are available from the Hornady Manufacturing Co., P.O. Box 1848, Grand Island, Nebr. 68801 in lots of 500.