



Designation: C 1541 – 02

Standard Specification for Shielded Transition Couplings Using Flexible Poly Vinyl Chloride (PVC) Gaskets to Connect Dissimilar DWV Pipe and Fittings¹

This standard is issued under the fixed designation C 1541; the number immediately following the designation indicates the year of original adoption or, in the case of revision, the year of last revision. A number in parentheses indicates the year of last reapproval. A superscript epsilon (ϵ) indicates an editorial change since the last revision or reapproval.

1. Scope

1.1 This specification covers the performance of shielded transition couplings using flexible PVC gaskets to join dissimilar DWV pipe and fittings above and below ground up to and including 10-in. pipe and fittings.

1.2 The values stated in inch-pound units are to be regarded as the standard. The SI units given in parenthesis are for information only.

1.3 The committee with jurisdiction over this standard is not aware of any comparable standards of any other organization.

1.4 The following precaution pertains only to the test method portion, Sections 7 and 8 of this specification. *This standard does not purport to address all of the safety concerns, if any, associated with its use. It is the responsibility of the user of this standard to establish appropriate safety and health practices and determine the applicability of regulatory requirements prior to use.*

2. Referenced Documents

2.1 ASTM Standards:

- A 493 Specification for Stainless Steel Wire and Wire Rods for Cold Heading and Cold Forging²
- C 717 Terminology of Building Seals and Sealants³
- D 5926 Specification for Poly Vinyl Chloride (PVC) Gaskets for Drain Waste and Vent (DWV), Sewer, Sanitary, and Storm Plumbing Systems⁴

3. Terminology

3.1 Definitions:

3.1.1 Definitions of the following terms used in this specification are found in Terminology C 717.

3.2 Definitions of Terms Specific to This Standard:

3.2.1 *center stop, n*—an integral part of the gasket centered on the axial length of the gasket intended to limit the insertion depth of the pipe to be coupled.

¹ This specification is under the jurisdiction of ASTM Committee C24 on Building Seals and Sealants and is the direct responsibility of Subcommittee C24.75 on Gaskets and Couplings for Plumbing and Sewer Piping.
Current edition approved July 10, 2002. Published September 2002.

² Annual Book of ASTM Standards, Vol 01.03.

³ Annual Book of ASTM Standards, Vol 04.07.

⁴ Annual Book of ASTM Standards, Vol 08.04.

TABLE 1 Unrestrained Hydrostatic Joint Test

Pipe Size	Test Pressure
1½ to 5 in. (38 to 76 mm)	20 psi (138 kPa)
6 in. (152.4 mm)	18 psi (124 kPa)
8 in. (203.2 mm)	10 psi (69 kPa)
10 in. (254 mm)	6 psi (41.4 kPa)

3.2.2 *clamp assembly, n*—that portion of the coupling excluding the gasket.

3.2.3 *coupling, n*—the complete assembly.

3.2.4 *dissimilar DWV pipe and fittings, n*—pipe and fittings made of different materials or different outside diameters, or both.

3.2.5 *fitting, n*—parts of a pipeline other than straight pipes, valves, or couplings.

3.2.6 *gasket, n*—the elastomeric portion of the coupling.

3.2.7 *joint, n*—the point of assembly consisting of the coupling and the joined pipes or fittings, or both.

3.2.8 *shield, n*—an external metallic protective device designed to protect the sealing gasket from external elements that could cause failure of the sealing assembly.

4. Materials and Manufacture

4.1 Physical properties of Flexible PVC (Poly Vinyl Chloride) gaskets shall comply with Specification D 5926. The gaskets shall be permitted to be spliced or molded.

4.2 All steel parts shall be 300 series stainless steel meeting the requirements of Specification A 493 excluding copper bearing alloys.

5. Requirements

5.1 Couplings shall be supported with suitable hangers or support necessary to support the pipe, fitting, and contents. The support must be located within 18 in. of the center of the coupling.

5.2 The coupling shall not be installed in a location where the expected internal or external temperatures are below -30°F (-34°C) or exceed 130°F (54°C).

6. Elastomeric Gasket Requirements

6.1 The elastomeric gasket shall consist of one piece conforming to the physical requirements of 4.1.

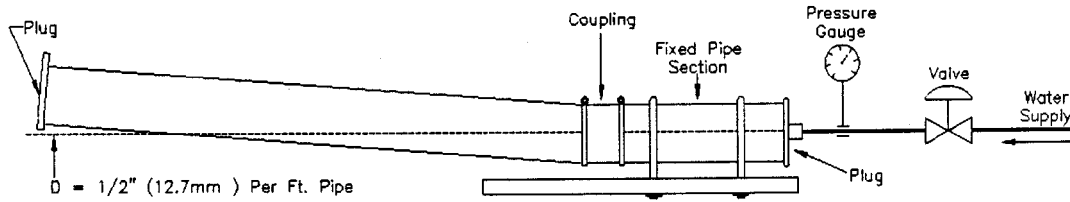

FIG. 1 Deflection Test

6.2 The elastomeric gasket shall have an inside center stop-ring spaced an equal distance from the ends to serve as a stop between the pipe/fitting ends. The center stop ring shall not create an enlargement chamber or recess with a ledge, shoulder or reduction of pipe area or offer an obstruction to flow. A gasket without an inside center stop shall be permitted in tubular transition applications, where telescoping of pipe is necessary.

6.3 The elastomeric gasket shall be free from imperfections and porosity that affects its use and serviceability.

7. Clamp Assembly Requirements

7.1 Stainless steel tension bands shall be tested to withstand 125 % of the manufacturer’s installation torque or a minimum of 60 in.-lbf of applied torque whichever is greater without visible signs of failure. The band shall be tested over a steel mandrel of the appropriate coupling diameter and torque as required.

7.2 Clamp assembly screws or bolts shall not have screw-driver slots.

8. Coupling Requirements and Test Methods

8.1 Assemble each coupling tested according to the manufacturer’s instructions between two sections of randomly selected pipe manufactured to appropriate standards for the type of pipe the couplings are expected to join. The pipe section will not exceed a length of 20 ft (6.1 m). Conduct the following tests:

8.2 *Deflection Test*—Each coupling tested shall be mounted between two pieces of pipe as provided in 8.1. The out bound ends of the pipe shall be closed with test plugs. The assembly shall be filled with water, all air expelled, and hydrostatically pressurized to 4.3 psi (29.6 kPa) for the duration of the test. One pipe shall be rigidly supported and while the assembly is under pressure, the opposite end of the other pipe shall be raised 1/2 in. (12.7 mm) per linear foot of pipe. The pressure shall be maintained for 15 min and leakage shall not be permitted. A test apparatus such as the one shown in Fig. 1 is suggested.

8.3 *Shear Test*—The assembly shall be filled with water, all air expelled, and hydrostatically pressurized to 4.3 psi (29.6 kPa) for the duration of the test. Two joined lengths of pipe selected as provided in 8.1 shall be supported on blocks at three locations. One length shall be supported on two blocks, one near the uncoupled end and the other immediately adjacent to the coupling. This length shall be firmly restrained in position (refer to Fig. 2). The other coupled length shall be supported by a single block 6 in. from (152.4 mm) the end of the pipe. A load of 50 pounds (22.7 kg) per inch of nominal diameter shall be applied at a point 6 in. (152.4 mm) from the edge of the coupling upon a 12 in. (304.8 mm) length of 3 by 3 (76.2 by 76.2 mm) angle iron or load distributing pad located on the top of the pipe immediately adjacent to the coupling of the pipe having one support only. When testing reducing couplings the load shall be applied to the reduced size. Under this loading there shall be no visible leakage or displacement of more than

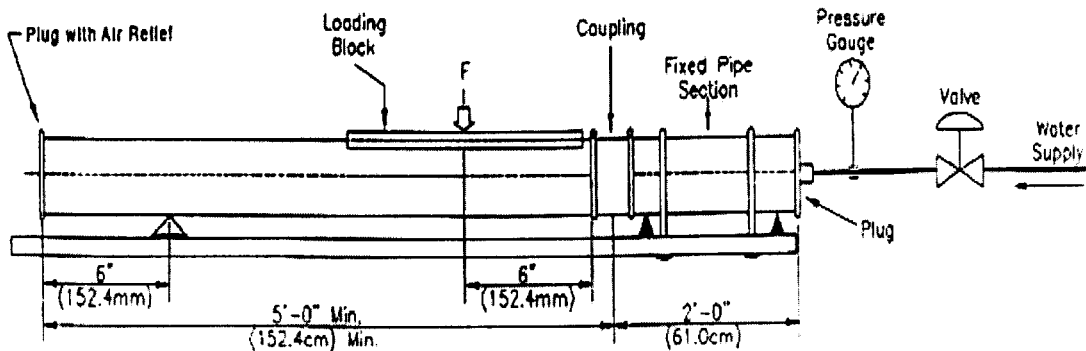

FIG. 2 Shear Testing Apparatus