



## Standard Test Method for Tensile Stress-Strain of Carbon and Graphite<sup>1</sup>

This standard is issued under the fixed designation C 749; the number immediately following the designation indicates the year of original adoption or, in the case of revision, the year of last revision. A number in parentheses indicates the year of last approval. A superscript epsilon ( $\epsilon$ ) indicates an editorial change since the last revision or reapproval.

### 1. Scope

1.1 This test method covers the testing of carbon and graphite in tension to obtain the tensile stress-strain behavior, to failure, from which the ultimate strength, the strain to failure, and the elastic moduli may be calculated as may be required for engineering applications. Table 1 lists suggested sizes of specimens that can be used in the tests.

NOTE 1—The results of about 400 tests, on file at ASTM as RR:C05-1000, show the ranges of materials that have been tested, the ranges of specimen configurations, and the agreement between the testers.

NOTE 2—For safety considerations, it is recommended that the chains be surrounded by suitable members so that at failure all parts of the load train behave predictably and do not constitute a hazard for the operator.

1.2 *This standard does not purport to address all of the safety concerns, if any, associated with its use. It is the responsibility of the user of this standard to establish appropriate safety and health practices and determine the applicability of regulatory limitations prior to use.*

1.3 The values stated in inch-pound units are to be regarded as the standard. The values given in parentheses are for information only.

### 2. Referenced Documents

2.1 *ASTM Standards:*

- E 4 Practices for Force Verification of Testing Machines<sup>2</sup>
- E 6 Terminology Relating to Methods of Mechanical Testing<sup>2</sup>
- E 177 Practice for Use of the Terms Precision and Bias in ASTM Test Methods<sup>3</sup>
- E 691 Practice for Conducting an Interlaboratory Study to Determine the Precision of a Test Method<sup>3</sup>

### 3. Terminology

3.1 *Definitions*—The terms as related to tension testing as given in Terminology E 6 shall be considered as applying to the terms used in this test method.

<sup>1</sup> This test method is under the jurisdiction of ASTM Committee D02 on Petroleum Products and Lubricants and is the direct responsibility of Subcommittee D02.F on Manufactured Carbon and Graphite Products.

Current edition approved Aug. 15, 1992. Published October 1992. Originally published as C 749 – 73. Last previous edition C 749 – 87.

<sup>2</sup> *Annual Book of ASTM Standards*, Vol 03.01.

<sup>3</sup> *Annual Book of ASTM Standards*, Vol 14.02.

### 4. Summary of Test Method

4.1 A tensile specimen (Fig. 1) is placed within a load train assembly made up of precision chains and other machined parts (Fig. 2). A load is applied to the specimen provided with means of measuring strain until it is caused to fracture. This test yields the tensile strength, elastic constants, and strain to failure of carbons and graphites.

### 5. Significance and Use

5.1 This test method is intended to be used for both carbons and graphites whose particle sizes are of the order of 1 mil to 1/4 in. (0.0254 to 6.4 mm) and larger. This wide range of carbons and graphites can be tested with uniform gage diameters with minimum parasitic stresses to provide quality data for use in engineering applications rather than simply for quality control. This test method can be easily adapted to elevated temperature testing of carbons and graphites without changing the specimen size or configuration by simply utilizing elevated temperature materials for the load train. This test method has been utilized for temperatures as high as 4352°F (2400°C). The design of the fixtures (Figs. 2-9 and Table 2) and description of the procedures are intended to bring about, on the average, parasitic stresses of less than 5 %. The specimens for the different graphites have been designed to ensure fracture within the gage section commensurate with experienced variability in machining and testing care at different facilities. The constant gage diameter permits rigorous analytical treatment.

### 6. Apparatus

6.1 *Testing Machine*—The machine used for tensile testing shall conform to the requirements of Practices E 4. The testing machine shall have a load measurement capacity such that the breaking load of the test specimen falls between 10 and 90 % of the scale capacity. This range must be linear to within 1 % over 1 % increments either by design or by calibration.

#### 6.2 *Strain Measurements:*

6.2.1 The axial strain can be measured at room temperature by the use of strain gages, mechanical extensometers, Tucker-man gages, optical systems, or other devices applied diametrically opposite in the gage length portion of the specimen. Two opposing gages provide some compensation for bending and some assurance that it was not severe. Different graphites

TABLE 1 Sample Sizes Used in Round-Robin Tests<sup>A</sup> (Suggested Specimen Size<sup>A</sup>)

| Material <sup>B</sup> | Max Grain Size, in. | Sample, in.                        | Specimen Size, in.  | Recommended Shank and Maximum Gage, in.  |
|-----------------------|---------------------|------------------------------------|---|--|
| AXM-50                | 0.001               | 5 by 5 by 5, molded                | 1/2 by 0.200 <sup>C</sup>   | 1/2 by 3/16<br>3/4 by 1/4                |
| 9326                  | 0.001               | 20 by 10 by 2, molded              | 1/2 by 1/4<br>3/4 by 0.3<br>1/2 by 3/16 <sup>C</sup>                            | 1/2 by 3/16<br>3/4 by 1/4<br>1/2 by 3/16 |
| 9326A                 | 0.001               | 20 by 10 by 2, molded              | 1/2 by 1/4<br>3/4 by 3/8<br>3/4 by 0.3<br>3/4 by 3/8                            | 3/4 by 0.3<br>3/4 by 3/16                |
| ATJ                   | 0.006               | 13, rounds, molded                 | 1/2 by 1/4<br>3/4 by 3/8<br>3/4 by 3/8<br>3/4 by 3/8                            | 1/2 by 1/4<br>3/4 by 1/4<br>3/4 by 1/4   |
| HLM                   | 0.033               | molded, 10 by 18 by 25             | 1/2 by 1/4<br>3/4 by 3/8<br>3/4 by 3/8  | 3/4 by 3/8                               |
| CS                    | 0.030               | 10, rounds, extruded               | 2 by 1<br>3/4 by 3/8<br>1/2 by 1/4<br>1/2 by 1/4                                | 3/4 by 3/8                               |
| AGR                   | 0.250               | 25, rounds, extruded               | 2 by 1<br>2 by 1<br>2 by 1<br>1 1/4 by 5/8                                      | 2 by 1<br>1 1/4 by 5/8                   |
| CGE                   | 0.265               | 14, rounds, extruded               | 2 by 1 1/4<br>3/4 by 1/2<br>3/4 by 1/4<br>1/2 by 1/4 <sup>C</sup><br>1/2 by 1/4 | 2 by 1<br>3/4 by 1/4<br>1/2 by 0.2       |
| Graphitar Grade 86    | ...                 | carbon-graphite, resin impregnated | 1/2 by 1/4 <sup>C</sup><br>1/2 by 1/4   | 3/4 by 1/4<br>1/2 by 0.2                 |
| Purebon P-59          | ...                 | carbon-graphite, copper treated    | 3/4 by 1/4<br>1/2 by 1/4 <sup>C</sup><br>1/2 by 1/4                             | 3/4 by 1/4<br>1/2 by 3/16                |

<sup>A</sup> Based on RR:C5-1000 (see Note 1).

<sup>B</sup> Identity of suppliers available from ASTM Headquarters.

<sup>C</sup> Gas-bearings.

iteh Standards  
(<https://standards.iteh.ai>)  
Document Preview

ASTM C749-92(2002)

<https://standards.iteh.ai/catalog/standards/sist/55dc933e-903d-42da-a578-b153f8889a72/astm-c749-922002>

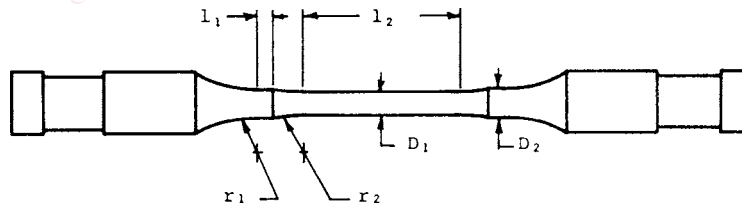

NOTE 1—Standard Specimen:

$r_1 = r_2$ ,

$A_1 = A_2/1.2$ ,

$l_1 = D_2/2$ , and

$l_2 = 2$  in. (51 mm) or  $8 D_1$ , whichever is greater.

FIG. 1 Double Reduction Used to Minimize Radii-Fractures

require different attachment procedures and extreme care is necessary. A proven device for mounting the specimen with minimum damage and for enabling the specimen to receive different extensometers is shown in Fig. 10. When attaching strain gages, the modification of the surface may result in a glue-graphite composite at the skin and thus the resulting strain values may be erroneous and typically low. When using clip-on extensometers, the knife edges can initiate fracture. Record, but do not include the fractures at the attachments in the

averages. If more than 20 % of the failures occur at the attachment location, change the strain monitoring system or attachment device.

6.2.2 The circumferential strain can be measured at room temperature by use of strain gages applied circumferentially. Knowledge of the anisotropy in the billet and orientation of the specimen is necessary in order to properly place the strain-measuring device. Generally, one can expect three values of Poisson's ratio for a nonisotropic material. Hence, the strain

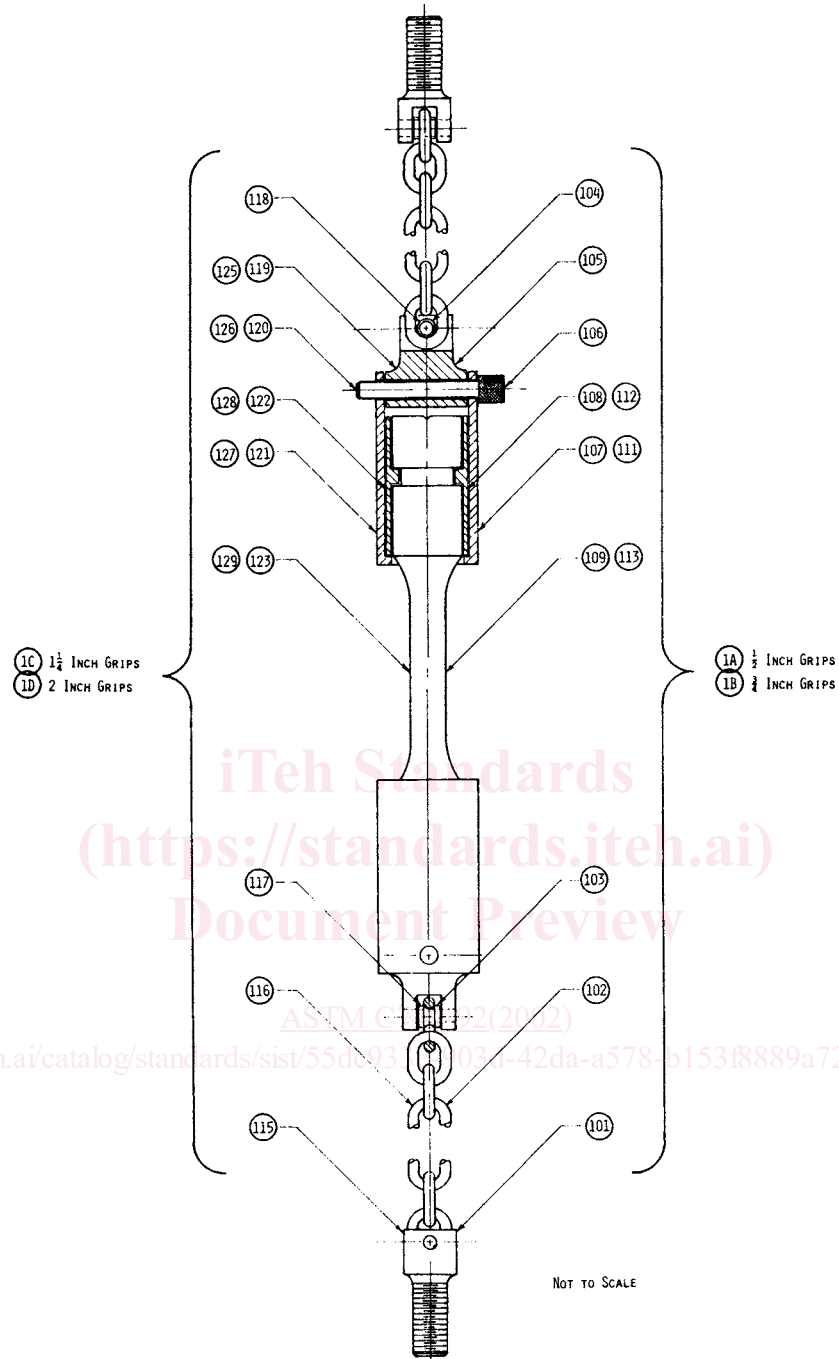

FIG. 2 Tensile Load Train Assembly

sensing devices must be sized and positioned carefully. Note the limitations on strain gages mentioned in 6.2.1.

6.2.3 The diametral strains can be measured by most of the devices with limitations mentioned in 6.2.1 and 6.2.2.

6.3 *Parasitic Stress Monitor*—An optional parasitic stress monitor can be inserted as an extension of one of the grips. It shall be a steel rod about 4 in. long with strain gages mounted at 90° angles to monitor axial bending moments on the rod and thus on the specimen. The rod shall be sized so that the bending moment applied to the specimen being used can be detected to

within a 5 % parasitic stress in the outer fiber of the specimen. The parasitic stress shall be calculated elastically by translating the moment and assuming that the specimen is a free-end beam.

6.4 *Gripping Devices*—Gripping devices that conform to those shown in Fig. 2 shall be used. The centerlines of all connections must align to within the tolerances shown throughout the test.

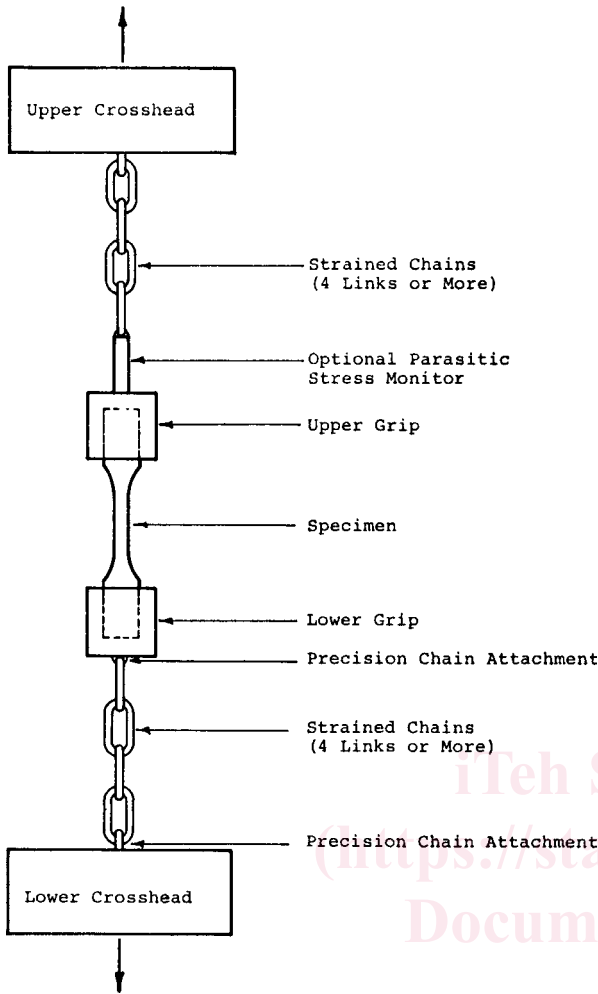

FIG. 3 Schematic of Tensile System for Carbon and Graphite

6.5 *General Test Arrangement*—The general arrangement of the specimen, flexible linkages, and crossheads shall be as shown in the schematic of Fig. 3.

7. Test Specimens

7.1 Test specimens shall be produced to the general configurations shown in Fig. 9. The selection of the proper ratio of shank to gage diameter is important to prevent excessive head-pops or fracture of the specimen at the groove in the shanks. The ratios shown in Table 1 have been found satisfactory for this use. It is acceptable to double reduce gage diameters as necessary (see Fig. 1) to eliminate head pops (or out-of-gage fractures) or reduce them to an acceptable 20 % maximum of the total fractures. However, the reducing radius must be maintained near the values shown or excessive radii breaks will be obtained. Also, the gage diameter should not be reduced to less than three to five times the maximum particles size in the material, or the failure mode may be atypical.

7.2 Improperly prepared test specimens often cause unsatisfactory test results. It is important, therefore, that care be exercised in the preparation of specimens both in minimizing end and side thrusts and in providing a quality surface. Stresses induced during preparation should not exceed 10 % of ultimate

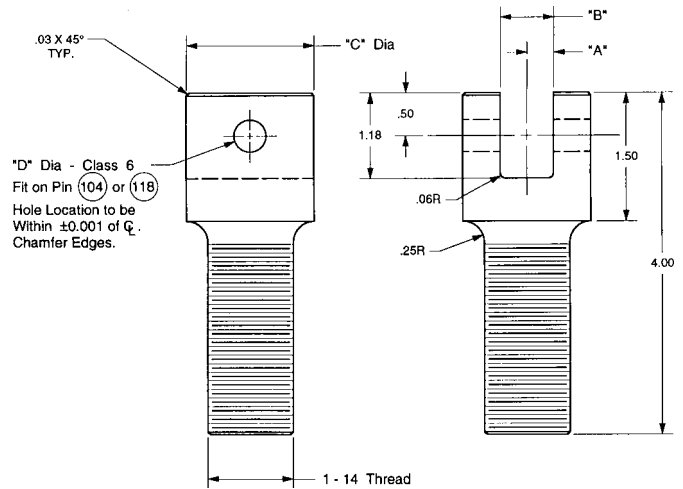

| Dimensions,<br>in. (mm) | Item                            |                                 |
|-------------------------|---------------------------------|---------------------------------|
|                         | 101                             | 115                             |
| A                       | 0.250 ± 0.001<br>(6.35 ± 0.03)  | 0.312 ± 0.001<br>(7.92 ± 0.03)  |
| B                       | 0.500 ± 0.001<br>(12.70 ± 0.03) | 0.625 ± 0.001<br>(15.88 ± 0.03) |
| C                       | 1.000<br>(25.40)                | 1.500<br>(38.10)                |
| D                       | 3/16<br>(4.76)                  | 3/8<br>(9.52)                   |

NOTE 1—Refer to Fig. 2, Items 101 and 115.

FIG. 4 Crosshead Attachment Yoke

fracture stress. Either tool cutting or grinding is acceptable, but the latter is preferred. Surface roughness should be no greater than the maximum particle or void size, whichever is greater. Usually, they are about equal.

7.3 The gage length of the specimen will be measured from the axial center of the specimen. Gage marks can be applied with ink or layout dope but no scratching, punching, or notching of the specimen is permissible. The gage length is to be used in referencing the point of fracture within 0.1 in. (2.5 mm). The total gage length is defined as that section with the smaller uniform diameter extending from radius tangent to radius tangent plus 10 %. The additional 10 % is intended to accommodate the normal statistics of fracture for a material like graphite. However, at least 50 % of the specimens should fracture within the uniform diameter or the specimen should be redesigned and the system checked. Acceptable fractured are shown in Fig. 11.

7.4 To determine the cross-sectional area, the diameter of the specimen at the smaller or constant diameter region shall be used. The dimension shall be recorded to the nearest 0.001 in. (0.254 mm).

8. Procedure

8.1 *Calibration*—Calibrate the micrometres that are to be used for measurement of diameters by measuring the dimensions of blocks provided by the NBS that are accurate within ±0.0001 in. (0.00254 mm). Calibrate all instrumentation and establish shunt calibration for each recorded and each parameter. Zero all recorders.

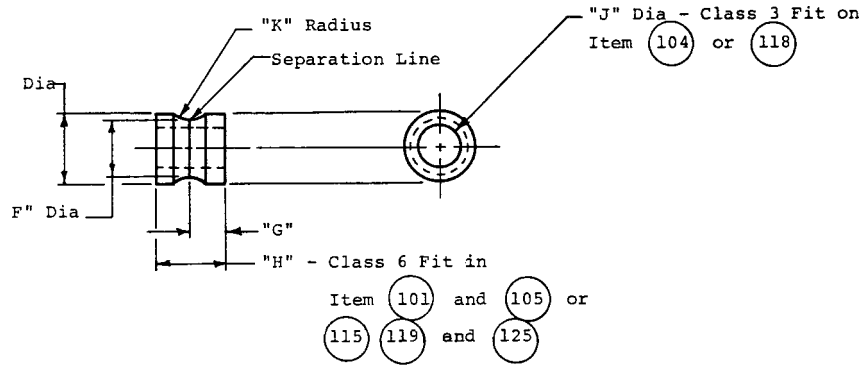

Not to Scale

| Dimensions<br>in. (mm) | 103                            | Item | 117                            |
|------------------------|--------------------------------|------|--------------------------------|
| E                      | 9/16<br>(14.29)                |      | 5/8<br>(15.88)                 |
| F                      | 5/16<br>(7.94)                 |      | 1/2<br>(12.7)                  |
| G                      | 0.250 ± 0.001<br>(6.35 ± 0.03) |      | 0.312 ± 0.001<br>(7.92 ± 0.03) |
| H                      | 0.500<br>(12.70)               |      | 0.625<br>(15.88)               |
| J                      | 3/16<br>(4.76)                 |      | 3/8<br>(9.52)                  |
| K                      | 1/8<br>(3.18)                  |      | 3/16<br>(4.76)                 |

NOTE 1—Refer to Fig. 2, Items 103 and 117.

FIG. 5 Chain Journal

8.2 *Specimen*—Adapt to the specimen the appropriate strain instrumentation by bonding strain gages to its surface, adapting, or any other strain measuring system so that strain can be measured during the test. Place the specimen within the load train. Make sure all instrumentation is properly calibrated and zeroed.

8.3 *Loading*—Apply the load at a predetermined constant stress rate by following the appropriate load time curve either manually or automatically. Continuously apply the load until fracture is induced.

8.4 *Recording*—During the entire load application duration, record the output of the load cell on the vertical axis of an X-Y recorder and the strain on the horizontal axis, and obtain a permanent record of the stress-strain curve for the specimen being tested during the entire test.

8.5 *Post Test*—Observed the specimen fracture surface. If the specimen failed outside the gage length as defined in 6.3 (including head pops), the strength value measured must be reported but not included in the average.

9. Calculation

9.1 Calculate the strength as follows:

$$\sigma_{ult} = \frac{P_{max}}{A} \tag{1}$$

where:

- $\sigma_{ult}$  = tensile strength, psi (Pa),
- $P_{max}$  = maximum load, lbf (N), and
- $A$  = cross-sectional area of the specimen in the constant diameter region or gage section, in.<sup>2</sup>(m<sup>2</sup>).

9.1.1 The cross-sectional area is given by the equation:

$$A = \frac{\pi D^2}{4} \tag{2}$$

where:

- $D$  = average diameter of the constant diameter region (gage section) of the specimen, in. (m).

9.2 Calculate modulus of elasticity of the specimen from the stress-strain curve as follows:

$$E = \text{initial slope of stress-strain curve} = \frac{\Delta\sigma}{\Delta\epsilon} \tag{3}$$

where:

- $E$  = modulus of elasticity, psi (Pa),
- $\Delta\sigma$  = incremental stress corresponding to the incremental strain, psi (Pa), and
- $\Delta\epsilon$  = incremental strain corresponding to the incremental stress, in./in. (m/m).

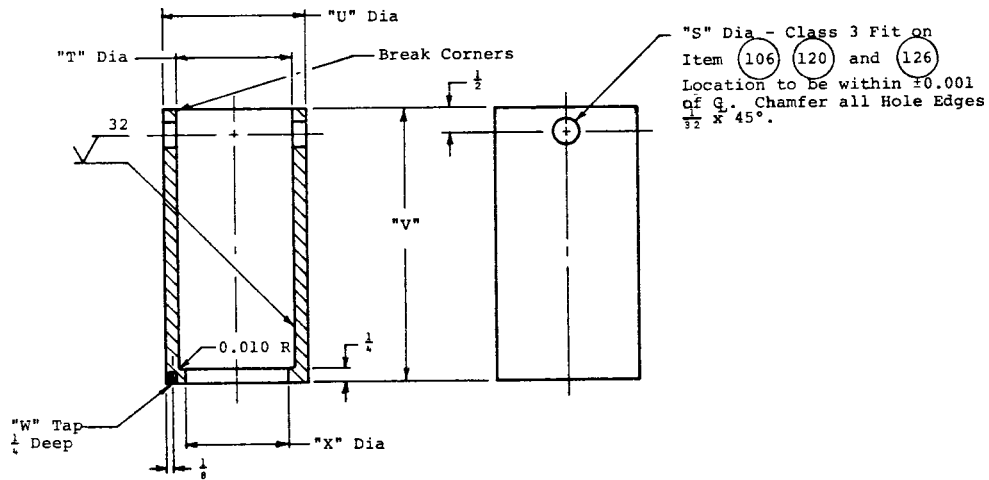

Not to Scale

| Dimensions,<br>in. (mm) | Item   |  |  |  |
|-------------------------|--|--|--|--|
|                         | 107  | 111  | 121  | 127  |
| S                       | $\frac{1}{4}$<br>(6.35)                                | $\frac{1}{4}$<br>(6.35)                                | $\frac{1}{2}$<br>(12.7)                                | $\frac{1}{2}$<br>(12.7)                                |
| T                       | $1.000 \pm 0.001$<br>(25.40 $\pm$ 0.03)                | $1.000 \pm 0.001$<br>(25.40 $\pm$ 0.03)                | $1.500 \pm 0.001$<br>(38.10 $\pm$ 0.03)                | $2.250 \pm 0.001$<br>(57.15 $\pm$ 0.03)                |
| U                       | 1.500<br>(38.10)                                       | 1.500<br>(38.10)                                       | 1.875<br>(47.62)                                       | 2.750<br>(69.85)                                       |
| V                       | $2\frac{5}{16}$<br>(58.74)                             | $2\frac{5}{16}$<br>(58.74)                             | $3\frac{3}{8}$<br>(92.07)                              | $5\frac{1}{2}$<br>(139.70)                             |
| W <sup>A</sup>          | 6-32   | 6-32   | 10-32  | 10-32  |
| X                       | $0.500 + 0.002$<br>- 0.000<br>(12.70 + 0.05<br>- 0.00) | $0.750 + 0.002$<br>- 0.000<br>(19.05 + 0.05<br>- 0.00) | $1.250 + 0.002$<br>- 0.000<br>(31.75 + 0.05<br>- 0.00) | $2.000 + 0.002$<br>- 0.000<br>(50.80 + 0.05<br>- 0.00) |

<sup>A</sup> Screw size.

NOTE 1—Refer to Fig. 2, Items 107, 111, 121, and 127.

FIG. 6 Grip Sleeve

<https://standards.iteh.ai/catalog/standards/sist/55dc933e-903d-42da-a578-b153f8889a72/astm-c749-922002>

9.3 Calculate the strain-to-failure from the stress-strain curve as the strain where the maximum stress was obtained and the specimen failed.

**10. Report**

10.1 Report the following information:

10.1.1 Method of testing, load rate, load calibrations, and other general testing information,

10.1.2 Material identification: manufacturer, grade number, lot number, original billet size, grain size, and other data, where available,

10.1.3 Description of the specimen including orientation and position in billet,

10.1.4 Description of procedures and other environmental exposures,

10.1.5 All individual and average ultimate tensile strength values,

10.1.6 Individual and average strain-to-failure values and details on the method of attachment of the strain sensing device. If elastic constants are given, the method of determining them should be reported,

10.1.7 Data for all samples tested including the monitored parasitic moment and calculated parasitic stress,

10.1.8 A record of all specimens that broke during machining or subsequent handling after they had been reduced to the nominal diameter used in the grips,

10.1.9 Standard deviation, coefficient of variation of all properties, or both. Usually, at least five to ten values are required for these numbers to have significance, and

10.1.10 Axial fracture location (see Fig. 11).

**11. Precision and Bias**

11.1 *Precision*—The precision statements given in this section are based on the comparison of the mean strength by the student *t* test and carrying out the statistical analysis of the data obtained on materials tested in a round-robin as recommended by Practice E 691.

11.1.1 *Comparison of the Means*—The comparison of the means by the student *t* test leads to the conclusion that the average of the strength values measured by each laboratory for each material can be considered statistically equal at a 95 % confidence level.

11.1.2 *Repeatability (Single Instrument)*—The precision within laboratory of two single values of measured strength using the Practice E 177 definition with the pooled standard