



Designation: D 92 – 02a

An American National Standard
American Association State
Highway and Transportation Officials Standard
AASHTO No.: T48
DIN 51 376



Designation: 36/84 (89)

Standard Test Method for Flash and Fire Points by Cleveland Open Cup Tester¹

This standard is issued under the fixed designation D 92; the number immediately following the designation indicates the year of original adoption or, in the case of revision, the year of last revision. A number in parentheses indicates the year of last reapproval. A superscript epsilon (ϵ) indicates an editorial change since the last revision or reapproval.

This standard has been approved for use by agencies of the Department of Defense.

INTRODUCTION

This flash point and fire point test method is a dynamic method and depends on definite rates of temperature increases to control the precision of the test method. Its primary use is for viscous materials having flash point of 79°C (175°F) and above. It is also used to determine fire point, which is a temperature above the flash point, at which the test specimen will support combustion for a minimum of 5 s. Do not confuse this test method with Test Method D 4206, which is a sustained burning test, open cup type, at a specific temperature of 49°C (120°F).

1. Scope *

1.1 This test method describes the determination of the flash point and fire point of petroleum products by a manual Cleveland open cup apparatus or an automated Cleveland open cup apparatus.

NOTE 1—The precisions for fire point were not determined in the current interlaboratory program. Fire point is a parameter that is not commonly specified, although in some cases, knowledge of this flammability temperature may be desired.

1.2 This test method is applicable to all petroleum products with flash points above 79°C (175°F) and below 400°C (752°F) except fuel oils.

NOTE 2—This test method may occasionally be specified for the determination of the fire point of a fuel oil. For the determination of the flash points of fuel oils, use Test Method D 93. Test Method D 93 should also be used when it is desired to determine the possible presence of small, but significant, concentrations of lower flash point substances that may escape detection by Test Method D 92. Test Method D 1310 can be employed if the flash point is known to be below 79°C (175°F).

1.3 The values stated in SI units are to be regarded as the standard. The values given in parentheses are for information only.

1.4 *This standard does not purport to address all of the safety concerns, if any, associated with its use. It is the responsibility of the user of this standard to establish appropriate safety and health practices and determine the applicability of regulatory limitations prior to use.* For specific hazard statements, see 6.4, 7.1, 11.1.3, and 11.2.4.

2. Referenced Documents

2.1 ASTM Standards:

- D 93 Test Methods for Flash Point by Pensky-Martens Closed Cup Tester²
 - D 140 Practice for Sampling Bituminous Materials³
 - D 1310 Test Method for Flash Point and Fire Points of Liquids by Tag Open-Cup Apparatus⁴
 - D 4057 Practice for Manual Sampling of Petroleum and Petroleum Products⁵
 - D 4177 Practice for Automatic Sampling of Petroleum and Petroleum Products⁵
 - D 4206 Test Method for Sustained Burning of Liquid Mixtures by the Setaflash Tester (Open-Cup)⁶
 - E 1 Specification for ASTM Thermometers⁷
 - E 300 Practice for Sampling Industrial Chemicals⁸
- ##### 2.2 IP Standard:⁹

¹ This test method is under the joint jurisdiction of ASTM Committee D02 on Petroleum Products and Lubricants and is the direct responsibility of Subcommittee D02.08 on Volatility. In the IP, this test method is under the jurisdiction of the Standardization Committee. This test method was adopted as a joint ASTM-IP standard in 1965. This test method has been adopted for use by government agencies to replace Method 1103.7 of Federal Test Method Standard No. 791b, and Method 4294 of Federal Test Method Standard No. 141A.

Current edition approved Sept. 10, 2002. Published October 2002. Originally published as D 92–21. Last previous edition D 92–02.

² *Annual Book of ASTM Standards*, Vol 05.01.

³ *Annual Book of ASTM Standards*, Vol 04.03.

⁴ *Annual Book of ASTM Standards*, Vol 06.01.

⁵ *Annual Book of ASTM Standards*, Vol 05.02.

⁶ *Annual Book of ASTM Standards*, Vol 06.01.

⁷ *Annual Book of ASTM Standards*, Vol 14.03.

⁸ Discontinued—See 2000 *Annual Book of ASTM Standards*, Vol 15.05.

⁹ Available from the Institute of Petroleum, 61 New Cavendish St., London, W1M 8AR, U.K.

***A Summary of Changes section appears at the end of this standard.**



Specifications for IP Standard Thermometers

2.3 ISO Standards:¹⁰

Guide 34 Quality Systems Guidelines for the Production of Reference Materials

Guide 35 Certification of Reference Material—General and Statistical Principles

3. Terminology

3.1 Definitions:

3.1.1 *dynamic, adj*—in petroleum products, the condition where the vapor above the test specimen and the test specimen are not in temperature equilibrium at the time that the ignition source is applied.

3.1.1.1 *Discussion*—This is primarily caused by the heating of the test specimen at the constant prescribed rate with the vapor temperature lagging behind the test specimen temperature.

3.1.2 *fire point, n*—in petroleum products, the lowest temperature corrected to a barometric pressure of 101.3 kPa (760 mm Hg), at which application of an ignition source causes the vapors of a test specimen of the sample to ignite and sustain burning for a minimum of 5 s under specified conditions of test.

3.1.3 *flash point, n*— in petroleum products, the lowest temperature corrected to a barometric pressure of 101.3 kPa (760 mm Hg), at which application of an ignition source causes the vapors of a specimen of the sample to ignite under specified conditions of test.

3.1.3.1 *Discussion*—The test specimen is deemed to have flashed when a flame appears and instantaneously propagates itself over the entire surface of the test specimen.

3.1.3.2 *Discussion*—When the ignition source is a test flame, the application of the test flame can cause a blue halo or an enlarged flame prior to the actual flash point. This is not a flash point and shall be ignored.

4. Summary of Test Method

4.1 Approximately 70 mL of test specimen is filled into a test cup. The temperature of the test specimen is increased rapidly at first and then at a slower constant rate as the flash point is approached. At specified intervals a test flame is passed across the cup. The flash point is the lowest liquid temperature at which application of the test flame causes the vapors of the test specimen of the sample to ignite. To determine the fire point, the test is continued until the application of the test flame causes the test specimen to ignite and sustain burning for a minimum of 5 s.

5. Significance and Use

5.1 The flash point is one measure of the tendency of the test specimen to form a flammable mixture with air under controlled laboratory conditions. It is only one of a number of properties that should be considered in assessing the overall flammability hazard of a material.

5.2 Flash point is used in shipping and safety regulations to define flammable and combustible materials. Consult the particular regulation involved for precise definitions of these classifications.

5.3 Flash point can indicate the possible presence of highly volatile and flammable materials in a relatively nonvolatile or nonflammable material. For example, an abnormally low flash point on a test specimen of engine oil can indicate gasoline contamination.

5.4 This test method shall be used to measure and describe the properties of materials, products, or assemblies in response to heat and a test flame under controlled laboratory conditions and shall not be used to describe or appraise the fire hazard or fire risk of materials, products, or assemblies under actual fire conditions. However, results of this test method may be used as elements of a fire risk assessment that takes into account all of the factors that are pertinent to an assessment of the fire hazard of a particular end use.

5.5 The fire point is one measure of the tendency of the test specimen to support combustion.

6. Apparatus

6.1 *Cleveland Open Cup Apparatus (manual)*—This apparatus consists of the test cup, heating plate, test flame applicator, heater, and supports described in detail in the Annex A1. The assembled manual apparatus, heating plate, and cup are illustrated in Figs. 1-3, respectively. Dimensions are listed with the figures.

6.2 *Cleveland Open Cup Apparatus (automated)*—This apparatus is an automated flash point instrument that shall perform the test in accordance with Section 11 Procedure. The apparatus shall use the test cup with the dimensions as described in Annex A1 and the application of the test flame shall be as described in Annex A1.

6.3 *Temperature Measuring Device*—A thermometer having the range as shown below and conforming to the requirements prescribed in Specification E 1 or in the Specifications for IP Standard Thermometers, or an electronic temperature measuring device, such as a resistance thermometer or thermocouple. The device shall exhibit the same temperature response as the mercury thermometers.

Temperature Range	Thermometer Number
-6 to +400°C	ASTM IP
20 to 760°F	11C 28C
	11F

6.4 *Test Flame*—Natural gas (methane) flame and bottled gas (butane, propane) flame have been found acceptable for use as the ignition source. The gas flame device is described in detail in Annex A1. (**Warning**—Gas pressure supplied to the apparatus must not be allowed to exceed 3 kPa (12 in.) of water pressure.)

NOTE 3—A shield, of the approximate dimensions 460 mm (18 in.) square and 610 mm (24 in.) high, or other suitable dimensions, and having an open front is recommended to prevent drafts from disturbing the vapors above the test cup.

7. Reagents and Materials

7.1 *Cleaning Solvents*—Use suitable technical grade solvent capable of cleaning out the test specimen from the test cup and

¹⁰ Available from American National Standards Institute (ANSI), 25 W. 43rd St., 4th Floor, New York, NY 10036.

ASTM D 92 - 02a

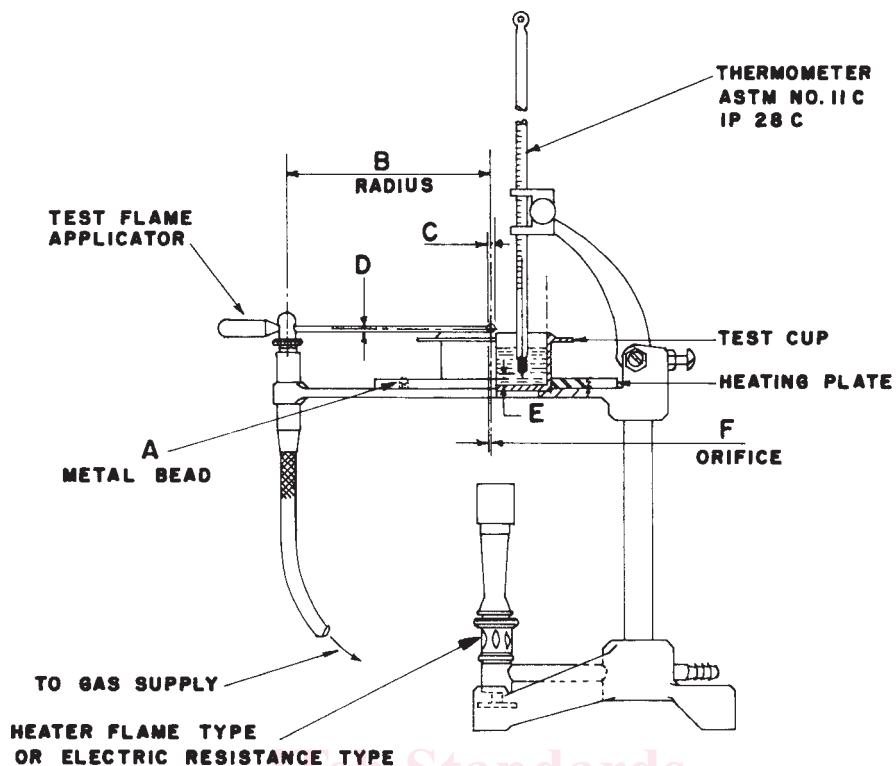

	millimetres		inches	
	min	max	min	max
A—Diameter	3.2	4.8	0.126	0.189
B—Radius	152	nominal	6	nominal
C—Diameter	1.6	nominal	0.063	nominal
D	2		0.078	
E	6	7	0.236	0.276
F—Diameter	0.8	nominal	0.031	nominal

FIG. 1 Cleveland Open Cup Apparatus

<https://standards.iteh.ai/catalog/standards/sist/566064d6-d53b-464e-9145-d21d572387b/astm-d92-02a>

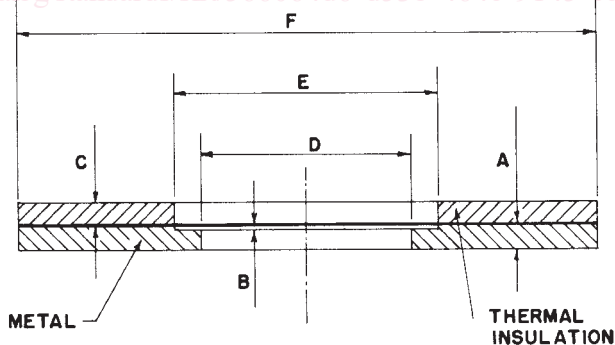

	millimetres		inches	
	min	max	min	max
A	6	7	0.26	0.276
B	0.5	1.0	0.020	0.039
C	6	7	0.236	2.276
D—Diameter	55	56	2.165	2.205
E—Diameter	69.5	70.5	2.736	2.776
F—Diameter	146	159	5.748	6.260

FIG. 2 Heating Plate

drying the test cup. Some commonly used solvents are toluene and acetone. (**Warning**—Toluene, acetone, and many solvents

are flammable. Health hazard. Dispose of solvents and waste material in accordance with local regulations.)

ASTM D 92 – 02a

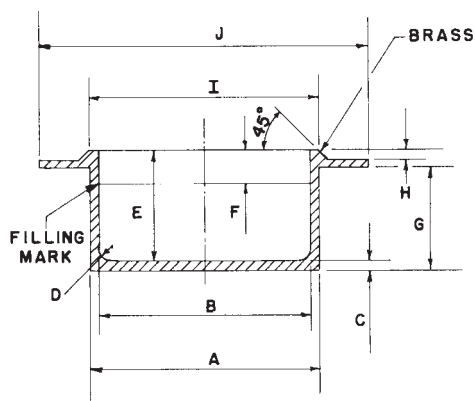

	millimetres		inches	
	min	max	min	max
A	67.5	69	2.658	2.717
B	63	64	2.480	2.520
C	2.8	3.5	0.110	0.138
D—Radius	4	nominal	0.157	nominal
E	32.5	34	1.280	1.339
F	9	10	0.354	0.394
G	31	32.5	1.221	1.280
H	2.8	3.5	0.110	0.138
I	67	70	2.638	2.756
J	97	100	3.819	3.937

FIG. 3 Cleveland Open Cup

8. Sampling

8.1 Obtain a sample in accordance with the instructions given in Practices D 140, D 4057, D 4177 or E 300.

8.2 At least 70 mL of sample is required for each test. Refer to Practice D 4057.

8.3 Erroneously high flash points may be obtained if precautions are not taken to avoid the loss of volatile material. Do not open containers unnecessarily; this will prevent loss of volatile material and possible introduction of moisture. Do not make a transfer of the sample unless the sample temperature is at least 56°C (100°F) below the expected flash point. When possible, flash point should be the first test performed on a sample and the sample should be stored at low temperature.

NOTE 4—Typical sample storage temperature is normal room temperature or lower.

8.4 Do not store samples in gas-permeable containers since volatile material may diffuse through the walls of the enclosure. Samples in leaky containers are suspect and not a source of valid results.

8.5 Light hydrocarbons may be present in the form of gases, such as propane or butane, and may not be detected by testing because of losses during sampling and filling of the test cup. This is especially evident on heavy residuums or asphalts from solvent extraction processes.

8.6 Samples of very viscous materials can be warmed until they are reasonably fluid before they are tested. However, no sample shall be heated more than is absolutely necessary. It shall never be heated above a temperature of 56°C (100°F) below its expected flash point. When the sample has been heated above this temperature, allow the sample to cool until it is at least 56°C (100°F) below the expected flash point before transferring.

NOTE 5—Typically, the sample containers for these types of samples

will remain closed during the warming process.

8.7 Samples containing dissolved or free water can be dehydrated with calcium chloride or by filtering through a qualitative filter paper or a loose plug of dry absorbent cotton. Samples of very viscous materials can be warmed until they are reasonably fluid before they are filtered, but they shall not be heated for prolonged periods or above a temperature of 56°C (100°F) below its expected flash point.

NOTE 6—If the sample is suspected of containing volatile contaminants, the treatment described in 8.6 and 8.7 should be omitted.

9. Preparation of Apparatus

9.1 Support the manual or automated apparatus on a level steady surface, such as a table.

9.2 Tests are to be performed in a draft-free room or compartment. Tests made in a laboratory hood or in any location where drafts occur are not to be relied upon.

NOTE 7—A shield, of the approximate dimensions 460 mm (18 in.) square and 610 mm (24 in.) high, or other suitable dimensions, and having an open front is recommended to prevent drafts from disturbing the vapors above the test cup.

NOTE 8—With some samples whose vapors or products of pyrolysis are objectionable, it is permissible to place the apparatus along with a shield into a hood, the draft of which is adjusted so that the vapors may be withdrawn without causing air currents over the test cup during the final 56°C (100°F) rise in temperature prior to the flash point.

9.3 Wash the test cup with the cleaning solvent to remove any test specimen or traces of gum or residue remaining from a previous test. If any deposits of carbon are present, they should be removed with a material such as a very fine grade of steel wool. Ensure that the test cup is completely clean and dry before using again. If necessary, flush the test cup with cold water and dry for a few minutes over an open flame or a hot

plate to remove the last traces of solvent and water. Cool the test cup to at least 56°C (100°F) below the expected flash point before using.

9.4 Support the temperature measuring device in a vertical position with the bottom of the device located 6.4 ± 0.1 mm ($1/4 \pm 1/50$ in.) up from the bottom of the inside of the test cup and located at a point halfway between the center and the side of the test cup on a diameter perpendicular to the arc (or line) of the sweep of the test flame and on the side opposite to the test flame applicator mounting position.

NOTE 9—The immersion line engraved on the ASTM or IP thermometer will be 2 ± 0.1 mm ($5/64 \pm 1/50$ in.) below the level of the rim of the cup when the thermometer is properly positioned.

NOTE 10—Some automated apparatus is capable of positioning the temperature measuring device automatically. Refer to the manufacturer's instructions for proper installation and adjustment.

9.5 Prepare the manual apparatus or the automated apparatus for operation according to the manufacturer's instructions for calibrating, checking, and operating the equipment.

10. Calibration and Standardization

10.1 Adjust the automated flash point detection system, when used, according to the manufacturer's instructions.

10.2 Calibrate the temperature measuring device according to the manufacturer's instructions.

10.3 Verify the performance of the manual apparatus or the automated apparatus at least once per year by determining the flash point of a certified reference material (CRM), such as those listed in Annex A2, which is reasonably close to the expected temperature range of the samples to be tested. The material shall be tested according to the procedure of this test method and the observed flash point obtained in 11.1.10 or 11.2.5 shall be corrected for barometric pressure (see Section 12). The flash point obtained shall be within the limits stated in Table A2.1 for the identified CRM or within the limits calculated for an unlisted CRM (see Annex A2).

10.4 Once the performance of the apparatus has been verified, the flash point of secondary working standards (SWSs) can be determined along with their control limits. These secondary materials can then be utilized for more frequent performance checks (see Annex A2).

NOTE 11—The verification fluid is a material with a predetermined, interlaboratory tested, flash point temperature that is used to verify proper operation of the apparatus. Calibration is undertaken by the operator according to the apparatus manufacturers' instructions should the result of the verification be outside the stated reproducibility.

10.5 When the flash point obtained is not within the limits stated in 10.3 or 10.4, check the condition and operation of the apparatus to ensure conformity with the details listed in Annex A1, especially in regard to the position of the temperature measuring device, the application of the test flame, and the heating rate. After adjustment of the apparatus, repeat the test with a fresh test specimen (see 10.3) with special attention to the procedural details prescribed in Section 11.

11. Procedure

11.1 Manual Apparatus:

11.1.1 Fill the test cup with the sample so that the top of the meniscus of the test specimen is exactly at the filling mark, and

place the test cup on the center of the heater. The temperature of the test cup and the sample shall not exceed 56°C (100°F) below the expected flash point. If too much test specimen has been added to the cup, remove the excess using a syringe or similar device for withdrawal of fluid. However, if there is test specimen on the outside of the test cup, empty, clean, and refill it. Destroy any air bubbles or foam on the surface of the test specimen with a sharp knife or other suitable device and maintain the required level of test specimen. If a foam persists during the final stages of the test, terminate the test and disregard any results.

11.1.2 Solid material shall not be added to the test cup. Solid or viscous samples shall be heated until they are fluid before being poured into the test cup; however, the temperature of the sample during heating shall not exceed 56°C (100°F) below the expected flash point.

11.1.3 Light the test flame and adjust it to a diameter of 3.2 to 4.8 mm ($1/8$ to $3/16$ in.) or to the size of the comparison bead, if one is mounted on the apparatus (see Annex A1). (**Warning**—Gas pressure supplied to the apparatus must not be allowed to exceed 3 kPa (12 in.) of water pressure.) (**Warning**—Exercise care when using a gas test flame. If it should be extinguished it will not ignite the vapors in the test cup, and the gas for the test flame that then enters the vapor space can influence the result.) (**Warning**—The operator shall exercise care and take appropriate safety precautions during the initial application of the test flame since test specimens containing low-flash material can give an abnormally strong flash when the test flame is first applied.) (**Warning**—The operator shall exercise care and take appropriate safety precautions during the performance of this test method. The temperatures attained during this test, up to 400°C (752°F), are considered hazardous.)

11.1.4 Apply heat initially at such a rate that the temperature as indicated by the temperature measuring device increases 14 to 17°C (25 to 30°F)/min. When the test specimen temperature is approximately 56°C (100°F) below the expected flash point, decrease the heat so that the rate of temperature rise during the last 28°C (50°F) before the flash point is 5 to 6°C (9 to 11°F)/min.

11.1.5 Apply the test flame when the temperature of the test specimen is approximately 28°C below the expected flash point and each time thereafter at a temperature reading that is a multiple of 2°C. Pass the test flame across the center of the test cup at right angles to the diameter, which passes through the temperature measuring device. With a smooth, continuous motion, apply the test flame either in a straight line or along the circumference of a circle having a radius of at least 150 ± 1 mm (6.00 ± 0.039 in.). The center of the test flame shall move in a horizontal plane not more than 2 mm ($5/64$ in.) above the plane of the upper edge of the test cup and passing in one direction only. At the time of the next test flame application, pass the test flame in the opposite direction of the preceding application. The time consumed in passing the test flame across the test cup in each case shall be approximately 1 ± 0.1 s.

NOTE 12—When determining the flash point of asphalt, it is recommended to carefully move fully to one side, such as with a spatula, any surface film formed before each application of the ignition source.

Available data indicate that higher flash point is observed for asphalt samples when surface film formed is not moved aside, compared to the flash point observed when the surface film is moved aside prior to the application of the ignition source.

NOTE 13—An alternative to the moving aside of the formed surface film can be found in Appendix X1.

11.1.6 During the last 28°C (50°F) rise in temperature prior to the expected flash point, care shall be taken to avoid disturbing the vapors in the test cup with rapid movements or drafts near the test cup.

11.1.7 When a foam persists on top of the test specimen during the last 28°C (50°F) rise in temperature prior to the expected flash point, terminate the test and disregard any results.

11.1.8 Meticulous attention to all details relating to the test flame, size of the test flame, rate of temperature increase, and rate of passing the test flame over the test specimen is required for proper results.

11.1.9 When testing materials where the expected flash point temperature is not known, bring the material to be tested and the test cup to a temperature no greater than 50°C (122°F), or when the material required heating to be transferred into the test cup, bring the material to that temperature. Apply the test flame, in the manner described in 11.1.5, beginning at least 5°C (9°F) above the starting temperature. Continue heating the test specimen at 5 to 6°C (9 to 11°F)/min and testing the material every 2°C (5°F) as described in 11.1.5 until the flash point is obtained.

NOTE 14—Flash point results determined in an unknown expected flash point mode should be considered approximate. This value can be used as the expected flash point when a fresh specimen is tested in the standard mode of operation.

11.1.10 Record, as the observed flash point, the reading on the temperature measuring device at the time the test flame causes a distinct flash in the interior of the test cup.

11.1.10.1 The sample is deemed to have flashed when a large flame appears and instantaneously propagates itself over the entire surface of the test specimen.

11.1.11 The application of the test flame can cause a blue halo or an enlarged flame prior to the actual flash point. This is not a flash point and shall be ignored.

11.1.12 When a flash point is detected on the first application of the test flame, the test shall be discontinued, the result discarded, and the test repeated with a fresh test specimen. The first application of the test flame with the fresh test specimen shall be at least 28°C (50°F) below the temperature found when the flash point was detected on the first application.

11.1.13 When the apparatus has cooled down to a safe handling temperature, less than 60°C (140°F), remove the test cup and clean the test cup and the apparatus as recommended by the manufacturer.

NOTE 15—Exercise care when cleaning the apparatus so as not to damage or dislocate the automated flash detection system, when used, or temperature measuring device. See the manufacturer's instructions for proper care and maintenance.

11.1.14 To determine the fire point, continue heating the test specimen after recording the flash point such that the test specimen temperature increases at a rate of 5 to 6°C (9 to

11°F)/min. Continue the application of the test flame at 2°C (5°F) intervals until the test specimen ignites and sustains burning for a minimum of 5 s. Record the temperature of the test specimen when the test flame, which caused the test specimen to ignite was applied. Sustain burning as the observed fire point of the test specimen.

11.1.15 When the apparatus has cooled down to a safe handling temperature, less than 60°C (140°F), remove the test cup and clean the test cup and the apparatus as recommended by the manufacturer.

11.2 Automated Apparatus:

11.2.1 The automated apparatus shall be capable of performing the procedure as described in 11.1, including control of the heating rate, application of the test flame, detection of the flash point, or fire point, or both, and recording the flash point or fire point, or both.

11.2.2 Fill the test cup with the sample so that the top of the meniscus of the test specimen is exactly at the filling mark, and place the test cup on the center of the heater. The temperature of the test cup and the sample shall not exceed 56°C (100°F) below the expected flash point. If too much test specimen has been added to the cup, remove the excess using a syringe or similar device for withdrawal of fluid; however, if there is test specimen on the outside of the test cup, empty, clean, and refill it. Destroy any air bubbles or foam on the surface of the test specimen with a sharp knife or other suitable device, and maintain the required level of test specimen. If a foam persists during the final stages of the test, terminate the test, and disregard any results.

11.2.3 Solid material shall not be added to the test cup. Solid or viscous samples shall be heated until they are fluid before being poured into the test cup; however, the temperature of the sample during heating shall not exceed 56°C (100°F) below the expected flash point.

11.2.4 Light the test flame, when necessary, and adjust it to a diameter of 3.2 to 4.8 mm ($\frac{1}{8}$ to $\frac{3}{16}$ in.) or to the size of the comparison bead, if one is mounted on the apparatus. (**Warning**—Gas pressure supplied to the apparatus must not be allowed to exceed 3 kPa (12 in.) of water pressure.) (**Warning**—Exercise care when using a gas test flame. If it should be extinguished it will not ignite the vapors in the test cup, and the gas for the test flame that then enters the vapor space can influence the result.) (**Warning**—The operator shall exercise care and take appropriate safety precautions during the initial application of the test flame since test specimens containing low-flash material can give an abnormally strong flash when the test flame is first applied.) (**Warning**—The operator shall exercise care and take appropriate safety precautions during the performance of this test method. The temperatures attained during this test, up to 400°C (752°F), are considered hazardous.)

NOTE 16—Some automated apparatus can light the test flame automatically and the size of the flame is preset.

11.2.5 Start the automated apparatus according to the manufacturer's instructions. The apparatus shall follow the procedural details described in 11.1.4 through 11.1.15.