



Standard Specification for Motorized Treadmills¹

This standard is issued under the fixed designation F 2115; the number immediately following the designation indicates the year of original adoption or, in the case of revision, the year of last revision. A number in parentheses indicates the year of last reapproval. A superscript epsilon (ϵ) indicates an editorial change since the last revision or reapproval.

INTRODUCTION

The goal of this specification is to promote proper mechanical design and manufacturing practices for motorized treadmills. Through these practices, this specification aims to assist designers and manufacturers in producing functional, safe machines under proper operational conditions. The equipment user must recognize, however, that a standard alone will not necessarily prevent injuries. Like other physical activities, exercise involving treadmills involves the risk of injury, particularly if the equipment is used improperly. The designers and manufacturers of treadmills should also consider other standards including, but not limited to, those listed below. This specification does not apply to treadmills designed for underwater use.

1. Scope

1.1 This specification covers the establishment of parameters for the design and manufacture of motorized treadmills.

2. Referenced Documents

2.1 ASTM Standards:

F 1749 Specification for Fitness Equipment and Facility Safety Signage and Labels²

F 2106 Test Method for Evaluating Design and Performance Characteristics of Motorized Treadmills²

2.2 UL Standards:³

UL 1647 Motor Operated Massage and Exercise Machines

UL 961 Electric Hobby and Sports Equipment

UL 1439 Test for Sharpness of Edges on Equipment

UL 2111 Thermal Protectors for Motors

2.3 European Standards:⁴

EN 957-1 Stationary Training Equipment—Part 1: General Safety Requirements and Test Methods

pr EN 957-6 Stationary Training Equipment—Part 6: Treadmills, Additional Specific Safety Requirements and Test Methods

3. Terminology

3.1 Definitions:

3.1.1 For treadmill terminology, see Fig. 1.

3.1.2 *accessible areas, n*—area accessible to the user or third party when the equipment is in normal use, during setting up, grasping, or correcting pieces of equipment or position of the body. This does not include areas that are accessible during the initial assembly.

3.1.3 *adjustable incline system, n*—components that allow the user to vary the angle of the moving surface relative to the floor.

3.1.4 *catch point, n*—location at which edges, protrusions, or surfaces allow a body part to become injured or clothing to be damaged.

3.1.5 *consumer treadmill, n*—treadmill intended exclusively for use by one person or a family unit in a home environment.

3.1.6 *folding treadmill, n*—a treadmill that is designed with some components that can be moved to allow a more compact, nonusable storage position.

3.1.7 *institutional treadmill, n*—treadmill intended for use by numerous persons in a commercial facility or institution as opposed to home environment.

3.1.8 *intended use, n*—operation in a manner consistent with use described in the owner's manual.

3.1.9 *owner's/user's manual, n*—documentation supplied and intended by the manufacturer to convey information to the owner/user about the treadmill.

3.1.10 *pinch point, n*—location between two moving components or the location between a moving and fixed component that, when entered, causes a portion of the body to become entrapped.

3.1.11 *pull in point, n*—the location between two moving components or the location between a moving and fixed component that, when entered, causes a portion of the body to be pulled into and trapped between the components.

¹ This specification is under the jurisdiction of ASTM Committee F08 on Sports Equipment and Facilities and is the direct responsibility of Subcommittee F08.30 on Fitness Products.

Current edition approved June 10, 2002. Published September 2002. Originally published as F 2115 – 01. Last previous edition F 2115 – 01.

² *Annual Book of ASTM Standards*, Vol 15.07.

³ Available from Underwriters Laboratories Inc., 333 Pfingsten Rd., Northbrook, IL 60062–2096.

⁴ Available from CEN Management Centre, 36 rue de Stassart, B-1050, Brussels, Belgium.

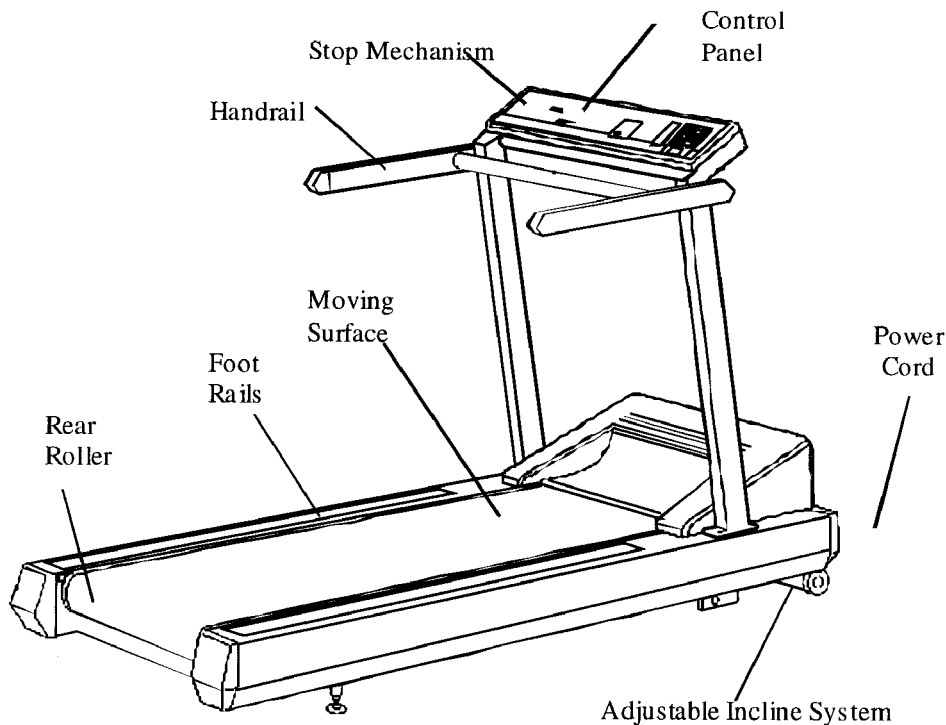

FIG. 1 Treadmill Terminology

3.1.12 *shear point, n*—location at which parts move past one another, a fixed point, or belt/pulley interfaces, so as to cause a body part to become caught in a scissors action.

3.1.13 *stop mechanism, n*—the device on the treadmill that, when actuated, removes power from the system that drives the moving surface or initiates a controlled stop.

3.1.14 *user support means, n*—see *hand rails*.

3.2 *Definitions of Terms Specific to This Standard:*

3.2.1 *control panel, n*—machine/user interface device for controlling the operation of or displaying information about the operational state of the treadmill.

3.2.2 *corner, n*—the intersection of three planes or surfaces on a single component.

3.2.3 *cycle, n*—refers to one application of load to specifications required in the standard followed by removal of that load.

3.2.4 *deck, n*—component that supports the moving surface.

3.2.5 *edge, n*—the intersection of two planes or surfaces on a single component.

3.2.6 *foot rail, n*—the area beside the moving surface intended for the user to stand on when mounting or dismounting or during a pause.

3.2.7 *handrail, n*—the means that are provided for a user to enhance balance and stability by partially or totally supporting the user's weight with the user's arms.

3.2.8 *motorized drive, n*—a system that causes motion in the moving surface—utilizing a power source other than the user.

3.2.9 *moving surface, n*—component(s) on which the user walks or runs.

3.2.10 *roller, n*—the cylindrical component of the treadmill used to tension or support the moving surface.

3.2.11 *steady state unloaded condition, n*—the operational state of the treadmill in which no user or other externally applied load has been applied to the treadmill and the moving surface speed has been allowed to stabilize as commanded by the user interface.

3.2.12 *treadmill, n*—a motorized stationary exercise device that allows the user to walk, jog, or run by means of traversing a continuous moving surface.

3.2.13 *usable moving surface, n*—the area of the moving surface that is clear of any obstructions that would impede normal foot motion including the portion of the stride prior to initial foot fall and therefore accessible for normal use. Where no obstructions exist, the tangency point of the roller and the belt is considered the end of the usable surface.

3.2.14 *user weight (maximum), n*—the mass of the exerciser that the treadmill was designed to safely accommodate. The manufacturer defines this value.

4. Design Requirements

4.1 Tests for conformance to design and loading requirements shall be performed in accordance with Test Method F 2106.

4.2 *Stability:*

4.2.1 The treadmill shall be stable during intended use.

4.3 *Exterior Design:*

4.3.1 *Edges*—All edges in accessible areas shall be free of burrs and sharp edges.

4.3.2 *Corners*—All corners in accessible areas shall be radiused or chamfered.

4.3.3 *Tube Ends*—Tube ends in the exposed accessible areas shall be closed off either by other components or plugs, caps, or covers.

4.3.4 The design of rotating parts shall avoid shear, pinch, or catch points by guarding, shielding, spacing, or other appropriate means.

4.3.5 The rear roller of the treadmill shall be designed or guarded to reduce the risk of finger entrapment. The guard or design shall function through the full range of inclination possible and through the full range of belt tension adjustment. The guard configurations shown in Fig. 2 are suggestions that may reduce the risks associated with this area. Fig. 2 assumes that the treadmill is maintained and adjusted per manufacturer's recommendations.

4.3.5.1 *Discussion*—The intention of Fig. 2 is to show some possible alternatives that have been used previously on treadmills to guard the rear roller area. This figure is not intended to limit alternatives that may more effectively address the hazard that is present at the rear roller. The function of the guard is to minimize the possibility of finger entrapment between the roller and the moving surface and between the frame and the end of the roller without introducing an undo tripping hazard to the user of the treadmill.

4.3.6 Electrical elements shall be guarded so as to meet or exceed UL 1647.

4.3.7 All treadmills shall be equipped with foot rails to facilitate user mounting and dismounting.

4.3.7.1 Foot rails shall be constructed to minimize foot slippage. A coefficient of friction of at least 0.5 must exist between the foot rail and a standard rubber test surface.

4.3.7.2 Foot rails shall be a minimum of 610 mm (24 in.) long and adjacent to the moving surface. They shall cover, as a minimum, from within 460 mm (18 in.) of the forward edge of the usable moving surface and at least 150 mm (6 in.) beyond the center of the usable moving surface. See Fig. 3.

4.3.7.3 For foot rail lateral spacing of 950 mm (37.5 in.) or

less, the minimum foot rail surface width dimension shall be 75 mm (3 in.). For foot rails spaced greater than 950 mm (37.5 in.), the minimum foot rail surface width dimension shall be 150 mm (6 in.). See Fig. 3.

4.3.8 *Moving Surface:*

4.3.8.1 The moving surface shall be constructed to minimize foot slippage. A coefficient of friction of at least 0.5 must exist between the side of the moving surface presented to the user and a standard rubber test surface.

4.3.8.2 The minimum dimensions of the usable moving surface shall meet the following requirements (maximum speed determined from test method for 4.8.3):

For Institutional Treadmills:

Maximum Speed	Minimum Width	Minimum Length
0 to 9.7 kph (0 to 6 mph)	400 mm (15.75 in.)	815 mm (32 in.)
>9.7 to 13 kph (>6 to 8 mph)	400 mm (15.75 in.)	965 mm (38 in.)
>13 to 16 kph (>8 to 10 mph)	400 mm (15.75 in.)	1090 mm (43 in.)
>16 kph (>10 mph)	400 mm (15.75 in.)	1270 mm (50 in.)

For Consumer Treadmills:

Maximum Speed	Minimum Width	Minimum Length
0 to 9.7 kph (0 to 6 mph)	325 mm (12.75 in.)	815 mm (32 in.)
>9.7 to 13 kph (>6 to 8 mph)	350 mm (13.75 in.)	965 mm (38 in.)
>13 to 16 kph (>8 to 10 mph)	350 mm (13.75 in.)	1090 mm (43 in.)
>16 kph (>10 mph)	400 mm (15.75 in.)	1270 mm (50 in.)

4.3.9 All treadmills shall be equipped with a handrail for user support during use and to assist in dismount. The handrail shall have a total grip length of at least 405 mm (16 in.), and at least one segment shall be a minimum of 200 mm (8 in.) long.

4.3.9.1 If the treadmill is not equipped with a front handrail, side handrails shall be included on both sides and have a maximum width of 965 mm (38 in.) measured centerline to centerline.

4.3.9.2 All handrails shall be a minimum of 800 mm (31.5

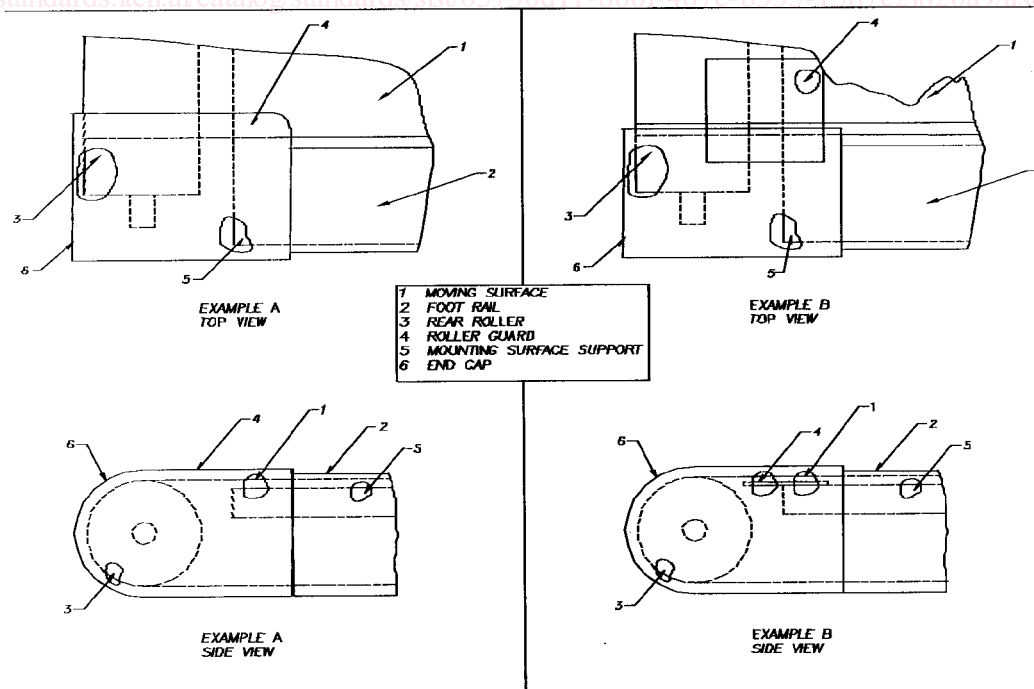

FIG. 2 Examples of Rear Roller Guarding