



Designation: F 606 – 02

Standard Test Methods for Determining the Mechanical Properties of Externally and Internally Threaded Fasteners, Washers, and Rivets¹

This standard is issued under the fixed designation F 606; the number immediately following the designation indicates the year of original adoption or, in the case of revision, the year of last revision. A number in parentheses indicates the year of last reapproval. A superscript epsilon (ϵ) indicates an editorial change since the last revision or reapproval.

This standard has been approved for use by agencies of the Department of Defense.

1. Scope

1.1 These test methods cover establishment of procedures for conducting tests to determine the mechanical properties of externally and internally threaded fasteners, washers, and rivets.

1.2 Property requirements and the applicable tests for their determination are specified in individual product standards. In those instances where the testing requirements are unique or at variance with these standard procedures, the product standard shall specify the controlling testing requirements.

1.3 These test methods describe mechanical tests for determining the following properties:

	Section
For Externally Threaded Fasteners:	3
Product Hardness	3.1
Proof Load	3.2.1
Method 1, Length Measurement	3.2.3
Method 2, Yield Strength	3.2.4
Method 3, Uniform Hardness	3.2.5
Axial Tension Testing of Full-Size Product	3.4
Wedge Tension Testing of Full-Size Product	3.5
Tension Testing of Machined Test Specimens	3.6
Total Extension at Fracture Test	3.7
Single Shear Test	3.8
For Internally Threaded Fasteners:	4
Product Hardness	4.1
Proof Load Test	4.2
Cone Proof Load Test	4.3
For Washers and Direct Tension Indicators:	5
General Requirements	5.1
Through Hardened Washers	5.2
Carburized Washers	5.3
For Rivets:	6
Product Hardness	6.1
Test for Embrittlement of Metallic-Coated Externally Threaded Fasteners	7

1.4 *This standard does not purport to address all of the safety concerns, if any, associated with its use. It is the responsibility of the user of this standard to establish appropriate safety and health practices and determine the applicability of regulatory limitations prior to use.*

NOTE 1—A complete metric companion to Test Methods F 606 has

¹ These test methods are under the jurisdiction of ASTM Committee F16 on Fasteners and are the direct responsibility of Subcommittee F16.01 on Test Methods.

Current edition approved Aug. 10, 2002. Published October 2002. Originally published as F 606 – 79. Last previous edition F 606 – 00.

been developed—F 606M; therefore, no metric equivalents are shown in these test methods.

2. Referenced Documents

2.1 ASTM Standards:

- A 394 Specification for Steel Transmission Tower Bolts, Zinc-Coated and Bare²
 - E 4 Practices for Force Verification of Testing Machines³
 - E 8 Test Methods of Tension Testing of Metallic Materials³
 - E 10 Test Method for Brinell Hardness of Metallic Materials³
 - E 18 Test Methods for Rockwell Hardness and Rockwell Superficial Hardness of Metallic Materials³
 - E 83 Practice for Verification and Classification of Extensometers³
 - F 436 Specification for Hardened Steel Washers²
 - F 606M Test Methods for Determining the Mechanical Properties of Externally and Internally Threaded Fasteners, Washers, and Rivets [Metric]²
 - F 959 Specification for Compressible-Washer-Type Direct Tension Indicators for Use With Structural Fasteners²
 - F 1624 Test Method for Measurement of Hydrogen Embrittlement in Steel by the Incremental Loading Technique⁴
- ### 2.2 Military Standard⁵:
- MIL STD 1312, Test 13 and Test 20

3. Test Methods for Externally Threaded Fasteners

3.1 *Product Hardness*—Tests shall be conducted after the removal of any surface oxide, decarburization, plating or other coating. All readings shall be within the hardness values listed in the product specification. The average of all readings on the same part shall be considered as the product hardness. Test results shall conform to the product specification for the lot represented by the test specimens to be considered conforming. Test specimen preparation and hardness tests shall be conducted in accordance with Test Method E 18 for Rockwell

² Annual Book of ASTM Standards, Vol 01.08.

³ Annual Book of ASTM Standards, Vol 03.01.

⁴ Annual Book of ASTM Standards, Vol 15.03.

⁵ Available from Standardization Documents Order Desk, Bldg. 4 Section D, 700 Robbins Ave., Philadelphia, PA 19111-5094, Attn: NPODS.

tests, Test Method E 10 for Brinell tests, Test Method E 92 for Vickers tests, or Test Method E 384 for Microhardness tests. The method used is at the option of the manufacturer, with regards to the size and grade of the products.

3.1.1 *Routine Test Locations*—For testing the hardness of the finished product, the following test locations can be used:

3.1.1.1 For hex and square head bolts; test shall be conducted on the wrench flats, top of head, unthreaded shank, end of bolt or at the arbitration location.

3.1.1.2 For studs, products without parallel wrench flats and for head styles other than hex and square; tests shall be conducted on the unthreaded shank, end of the bolt or stud or at the arbitration location.

3.1.1.3 Stress relieved products (3.1.1.1 and 3.1.1.2) are measured anywhere on the surface or through the cross section. Refer to the product specification for particular test location or use the arbitration location.

3.1.1.4 The Rockwell Hardness Scale may be used for all product diameters; however, the Brinell hardness is limited to products over 1½-in. nominal diameter.

3.1.2 *Laboratory Inspection*—After observing 3.1 and 3.1.1, a minimum of three readings shall be taken on each sample of finished product.

3.1.3 *Arbitration Test Location*—For purposes of arbitration between the purchaser and seller over reported test results, hardness tests shall be conducted at the mid-radius ($r/2$) of a transverse section through the threads taken at a distance of approximately one diameter from the point end of the bolt or one end of the stud. Four readings shall be taken from the point end of the bolt or one end of the stud. Four readings shall be taken approximately 90° to one another on the same plane, if product size permits. Smaller diameter products may also use the opposite parallel surface area of the bolt head end as sectioned above. (See Fig. 1). The use of Brinell hardness is limited to product sizes greater than 2¼-in. nominal diameter.

3.2 *Tension Tests*—It is preferred that bolts and studs be tested full size, and it is customary, when so testing, to specify a minimum ultimate load (or stress) in pounds-force (or pounds-force per square inch.) Paragraphs 3.2 through 3.5

apply when testing externally threaded fasteners full size. Paragraph 3.6 shall apply where the individual product specifications permit the use of machined specimens. (See Test Methods E 8.)

3.2.1 *Proof Load*—The proof-load test consists of stressing the product with a specified load that the product must withstand without measurable permanent set. Alternative tests for determining the ability of a fastener to pass the proof-load test are the yield strength test and the uniform hardness test. Either Method 1 (3.2.3), Method 2 (3.2.4), or Method 3 (3.2.5) may be used, but Method 1 shall be the arbitration method in case of any dispute as to acceptance of the product. (See Test Methods E 8.)

3.2.2 In both Methods 1 and 2, assemble the product in the fixture of the tension testing machine so that six complete threads (except for heavy hex structural bolts, which shall be based on four threads) are exposed between the grips. This is obtained by freely running the nut or fixture to the thread runout of the specimen and then unscrewing the specimen six full turns. For continuous thread bolts, at least six full threads shall be exposed between the fixture ends; however, for referee purposes, six full threads shall be exposed.

3.2.3 *Method 1, Length Measurement*—To ensure consistent and repetitive length measurements of the fastener, the threaded end and top of the bolt head shall have conical depressions made at the approximate axis or center line of the fastener. If raised or depressed markings on the head interfere with the placement of the measuring depressions, the head shall be carefully ground. The measuring instrument shall have pointed anvils which mate with the center line depressions and be capable of measuring changes in length of 0.0001 in. with an accuracy of 0.0001 in. in any 0.001 in. range. Place the fastener between the measuring anvils and rotate it approximately ¼ turn to the left center, right then center again to assure sound seating. Zero the instrument or record indicated measurement. If using a bolt extensometer, the bolt with attached extensometer may be assembled into the tension testing machine. If not, mark the fastener so it may be placed as close as possible to the same position for the second reading.

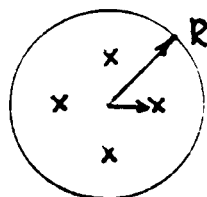
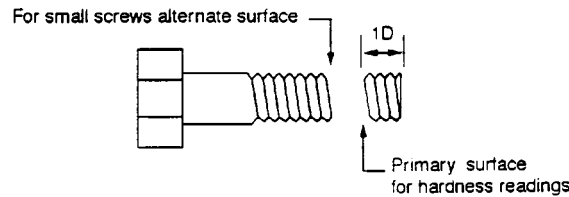

R = Radius
X = R/2

FIG. 1 Hardness Arbitration Test Location

Remove and assemble the fastener into the tension testing machine as outlined in 3.4. With a test speed which shall not exceed 0.12 in./min, as determined with a free-running cross head, axially load the fastener to the proof load value specified in the product specification. This load shall be maintained for a period of 10 s before releasing the load. Replace the fastener between the measuring anvils and rotate as before, stopping the mark at the same approximate position as the first reading. The measurement shall show no permanent elongation. A tolerance of ± 0.0005 in. shall be allowed (for measurement error only) between the measurement made before loading and that made after loading. Variables such as straightness, thread alignment, or measurement error could result in apparent elongation of the product when the specified proof load is initially applied. In such cases, the product may be retested using a 3 % greater load, and shall be considered acceptable if there is no difference in the length measurement after this loading within a 0.0005 in. measurement tolerance as outlined.

3.2.4 Method 2, Yield Strength—Assemble the product in the testing equipment as outlined in 3.4. As the load is applied, measure and record the total elongation of the product or any part of it that includes the exposed threads to produce a load-elongation diagram. Determine the load or stress at an offset equal to 0.2 % of the length of bolt occupied by six full threads as shown in Fig. 2 (except for heavy hex structural bolts, which shall be based on four threads) by the method described in 3.6.3.1.

3.2.4.1 Method 2A, Yield Strength for Austenitic Stainless Steel and Non-ferrous Materials—Assemble the product in the testing equipment as outlined in 3.4. As the load is applied, measure and record the total elongation of the product in order to produce a load elongation diagram. Determine the load or stress at an offset equal to 0.2 % strain based on the length of the bolt between the holders as shown in Fig. 2, which will be subject to elongation under load by using the method described in 3.6.3.1.

3.2.5 Method 3, Uniform Hardness—The fasteners shall be tested for hardness as described in 3.1, and in addition, the hardness shall also be determined in the core. The difference between the mid-radius and core hardness shall be not more than 3 points on a Rockwell C Scale; and both readings must be within product specification. This test is valid for fasteners up to and including 1 in. in diameter.

3.3 Bolts or Studs Too Short for Tension Testing—Product lengths less than those shown in Table 1 for product $\frac{1}{4}$ through $\frac{3}{4}$ in. in diameter and less than three diameters in length for product above $\frac{3}{4}$ in. in diameter, or that do not have sufficient threads for proper engagement and still leave the specified number of complete threads exposed between the grips, shall be deemed too short for tension testing, and acceptance shall be based on a hardness test performed in accordance with 3.1. If tests other than product hardness are required, their requirements should be referenced in the product specification.

3.4 Axial Tension Testing of Full-Size Products:

3.4.1 Test bolts in a holder with the load axially applied between the head and a nut or suitable fixture (Fig. 2), either of which shall have sufficient thread engagement to develop the full strength of the product. Assemble the nut or fixture on the product, leaving a minimum of six complete bolt threads exposed between the grips except for heavy hex structural bolts, which shall have four complete threads exposed between the grips.

3.4.2 Test studs by assembling one end in the threaded fixture to the thread runout. For studs having unlike threads, this shall be the end with the finer pitch thread, or with the larger minor diameter. Likewise, assemble the other end of the stud in a threaded fixture, leaving six complete threads exposed between the grips. For continuous thread studs, at least six complete threads shall be exposed between the fixture ends. The maximum speed of the free-running cross head shall not exceed 1 in./min. When reporting the tensile strength of

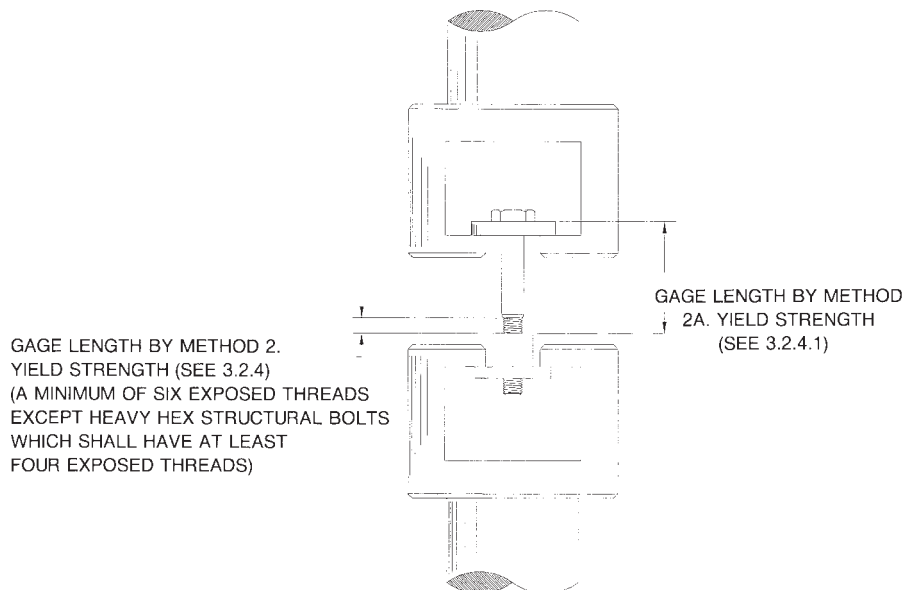

FIG. 2 Tension Testing of Full-Size Bolt (Typical Set-Up)

TABLE 1 Minimum Length of Product Requiring Tension Testing

Nominal Product Size, in.	Minimum Length, in.
1/4	5/8
5/16	3/4
3/8	7/8
7/16	1
1/2	1 1/8
9/16	1 1/4
5/8	1 1/2
3/4	1 3/4
7/8 and larger	3 dia

product, in pounds-force per square inch, calculate the thread stress area as follows:

$$A_s = 0.7854 [D - (0.9743)/n]^2 \quad (1)$$

where:

- A_s = thread stress area, in.²,
- D = nominal diameter of bolt or stud, in., and
- n = number of threads per inch.

3.4.3 To meet the requirements of the test described in 3.4.1 and 3.4.2, the product shall support a load prior to fracture not less than the minimum tensile strength specified in the product specification for its size, strength, and thread series. In addition, the tensile fracture shall occur in the body or threaded section with no fracture at the junction of head and shank.

3.5 *Wedge Tension Testing of Full-Size Product*—The wedge tensile strength of a hex or square-head fastener, socket-head cap screw (with the exception of socket button or flat countersunk head products) or stud is the tensile load that the product is capable of sustaining when stressed with a wedge under the head. The purpose of this test is to obtain the tensile strength and demonstrate the “head quality” and ductility of the product.

3.5.1 *Wedge Tension Testing of Bolts*—Determine the ultimate load of the bolt as described in 3.4 except place a wedge under the bolt head. When both wedge tension and proof load testing are required by the product specification use the proof load-tested bolts for wedge testing. The wedge shall have a minimum hardness of 45 HRC. Additionally, the wedge shall have a minimum thickness of one half the nominal bolt diameter (measured at the thin side of the hole, see Fig. 3). The wedge shall have an included angle as shown in Table 2 for the product type being tested. The hole in the wedge shall have a clearance over the nominal size of the bolt, and its edges top and bottom shall be rounded as specified in Table 3. The minimum outside dimension of the wedge shall be such that during the test no corner loading of the product head (adjacent to the wedge) shall occur. (See head (adjacent to the wedge) shall occur. (See head orientation in Fig. 3). The bolt shall be tension tested to fracture. To meet the requirements of this test, the bolt shall support a load prior to fracture not less than the minimum tensile strength specified in the product specification for the applicable size, grade, and thread series. In addition, the tensile fracture shall occur in the body or threaded section with no fracture at the junction of head and shank.

NOTE 2—Fracture at the junction of the head and shank is prohibited at any load, including those above the minimum requirements.

3.5.2 *Wedge Tension Testing of Studs*—When both wedge tension and proof load testing are required by the product specifications, assemble one end of the same stud previously used for proof load testing in a threaded fixture to the thread runout. For studs having unlike threads, this shall be the end with the finer pitch thread or with the larger minor diameter. Assemble the other end of the stud in a threaded wedge to the runout and then unscrew six full turns, thus leaving six complete threads exposed between the grips, as illustrated in Fig. 4. For continuous thread studs, at least six complete threads shall be exposed between the fixture ends. The angle of the wedge for the stud size and grade shall be as specified in Table 2. Assemble the stud in the testing machine and tension test to fracture, as described in 3.4. The minimum hardness of the threaded wedge shall be 45 HRC. The length of the threaded section of the wedge shall be equal to at least the diameter of the stud. To facilitate removal of the broken stud, counterbore the wedge. The thickness of the wedge at the thin side of the hole shall equal the diameter of the stud plus the depth of counterbore. The thread in the wedge shall have Class 3B tolerances, except when testing studs having an interference fit thread, in which case the wedge shall be threaded to provide a finger-free fit. The supporting fixture, as shown in Fig. 4, shall have a hole clearance over the nominal size of the stud, and shall have its top and bottom edges rounded or chamfered to the same limits specified for the hardened wedge in Table 3. To meet the requirements of this test, the stud shall support a load prior to fracture not less than the minimum tensile strength specified in the product specification for its size, grade, and thread series.

NOTE 3—Dimensional tolerances for all test fixtures used in this test method, unless otherwise noted, shall conform to standard machining practices.

3.6 *Tension Testing of Machined Test Specimens:* 02

3.6.1 Where bolts and studs cannot be tested full size, conduct tests using test specimens machined from the bolt or stud (see Test Methods E 8).

3.6.1.1 Bolts and studs 1/16 in. in diameter and smaller may be machined concentric with the axis of the bolt or stud. The specimen shall have a turned section as large as feasible and shall have a gage length four times the diameter of the specimen. See Fig. 5 and Fig. 6.

3.6.1.2 Bolts and studs 5/8 in. in diameter through 1 1/4 in. in diameter may have their shanks machined concentric with the axis of the bolt or stud, leaving the bolt head and threaded section intact as shown in Fig. 5. Alternatively, bolts and studs 5/8 in. in diameter through 1 1/4 in. in diameter may have their shanks machined to a test specimen with the axis of the specimen located midway between the axis and outside surface of the bolt or stud as shown in Fig. 7. Bolts of a small cross section that will not permit taking the 0.500-in. round, 2-in. gage length test specimen shall have a turned section as large as feasible and concentric with the axis of the bolt or stud. The gage length for measuring the elongation shall be four times the diameter of the specimen. Fig. 6 illustrates an example of these small-size specimens. For arbitration purposes, machined test specimens for bolts and studs 5/8 in. in diameter through

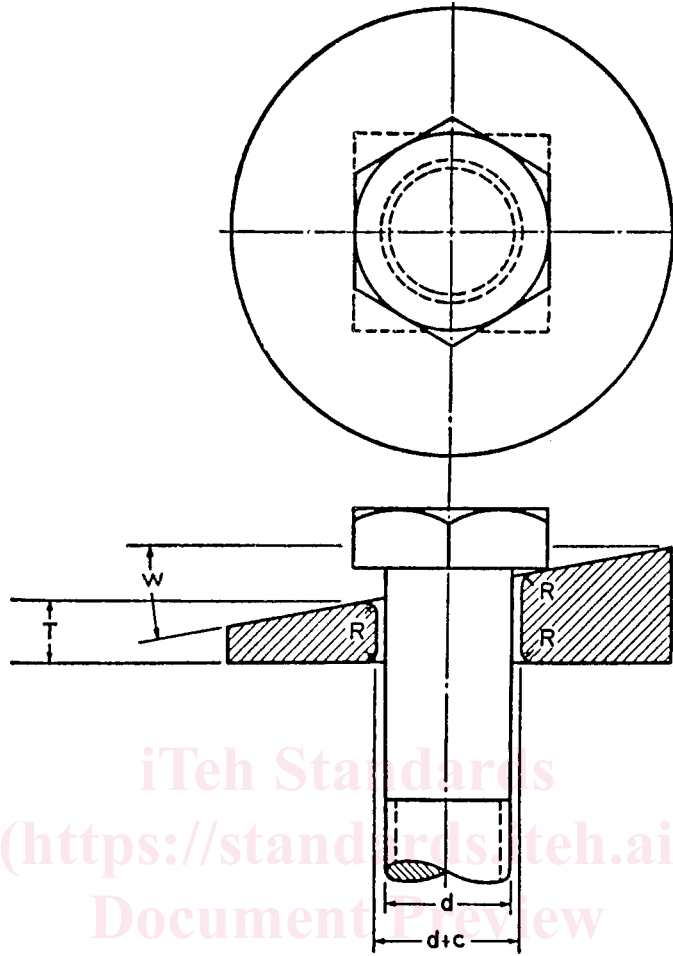

c = clearance of hole
 D = diameter of bolt or screw
 R = radius or chamfer
 T = reference thickness of wedge at thin side of hole equals one half diameter of bolt or screw
 W = wedge angle (see Table 2)

FIG. 3 Wedge Test Details—Bolts

TABLE 2 Tension Test Wedge Angles

Nominal Product Size, in.	Degrees	
	Bolts ^A	Studs and Flange Bolts
1/4 – 1	10	6
Over 1	6	4

^A Heat-treated bolts that are threaded one diameter or closer to the underside of the head, shall use a wedge angle of 6° for sizes 1/4 through 3/4 in. and 4° for sizes over 3/4 in.

TABLE 3 Tensile Test Wedge Hole Clearance—Details

Nominal Product Size, in.	Nominal Clearance in Hole, in.	Nominal Radius on Corners of Hole, in.
1/4 – 1/2	0.030	0.030
9/16 – 3/4	0.050	0.060
7/8 – 1	0.060	0.060
1 1/8 – 1 1/4	0.060	0.125
1 3/8 – 1 1/2	0.094	0.125
1 3/4 – 2	0.094	0.225
2 1/4 – 3	0.125	0.256

1 1/4 in. in diameter shall be machined with the axis of the specimen located midway between the center and outside surface.

3.6.1.3 Bolts and studs 1 3/8 in. in diameter and larger may have their shanks machined to the dimensions of a 0.500-in. round, 2-in. gage length test specimen with the axis of the specimen located midway between the center and outside surface of the bolt or stud as shown in Fig. 7.

3.6.1.4 Machined test specimens shall exhibit tensile strength, yield strength (or yield point), elongation, and reduction of area equal to or greater than the values of these properties specified for the product size in the applicable product specification when tested in accordance with this section.

3.6.2 Determination of Tensile Properties:

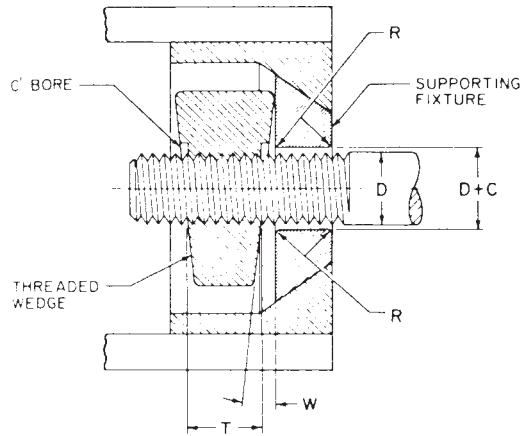

- C = clearance of hole (see Table 3)
- D = diameter of stud
- R = radius or chamfer (see Table 3)
- T = E plus depth of counterbore
- W = wedge angle (see Table 2)
- E = length of threaded section of wedge = D

FIG. 4 Wedge Test Details—Studs

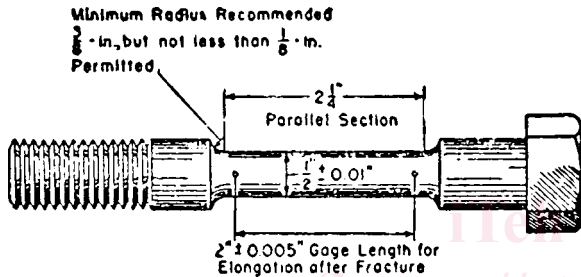

FIG. 5 Tension Test Specimen for Bolt with Turned-Down Shank

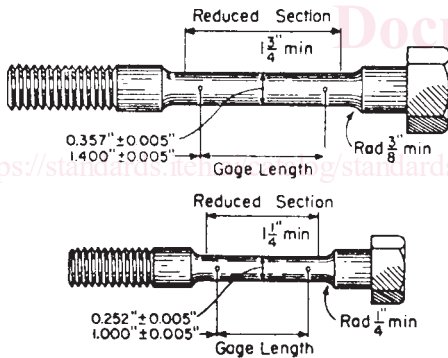

FIG. 6 Examples of Small-Size Specimens Proportional to Standard 2-in. Gage Length Specimen

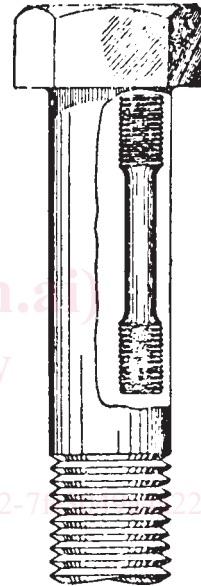

FIG. 7 Location of Standard Round 2-in. Gage Length Tension Test Specimen When Turned from Large Size Bolt

3.6.2.1 *Yield Point*—Yield point is the first stress in a material, less than the maximum obtainable stress, at which an increase in strain occurs without an increase in stress. Yield point is intended for application only for materials that may exhibit the unique characteristic of showing an increase in strain without an increase in stress. The stress-strain diagram is characterized by a sharp knee or discontinuity. Determine yield point by one of the following methods:

3.6.2.2 *Drop of the Beam or Halt of the Pointer Method*—In this method apply an increasing load to the specimen at a uniform rate. When a lever and poise machine is used, keep the beam in balance by running out the poise at approximately a steady rate. When the yield point of the material is reached, the increase of the load will stop, but run the poise a trifle beyond

the balance position, and the beam of the machine will drop for a brief but appreciable interval of time. When a machine equipped with a load-indicating dial is used, there is a halt or hesitation of the load-indicating pointer corresponding to the drop of the beam. Note the load at the “drop of the beam” or the “halt of the pointer” and record the corresponding stress as the yield point.

3.6.2.3 *Autographic Diagram Method*—When a sharp-kneed stress-strain diagram is obtained by an autographic recording device, take the stress corresponding to the top of the knee (Fig. 8), or the stress at which the curve drops as the yield point (Fig. 9).

3.6.2.4 *Total Extension Under Load Method*—When testing material for yield point and the test specimens may not exhibit a well-defined disproportionate deformation that characterizes a yield point as measured by the drop of the beam, halt of the pointer, or autographic diagram methods described in 3.6.2.2 and 3.6.2.3, a value equivalent to the yield point in its practical