



Designation: D 6113 – 02

## Standard Test Method for Using a Cone Calorimeter to Determine Fire-Test-Response Characteristics of Insulating Materials Contained in Electrical or Optical Fiber Cables<sup>1</sup>

This standard is issued under the fixed designation D 6113; the number immediately following the designation indicates the year of original adoption or, in the case of revision, the year of last revision. A number in parentheses indicates the year of last reapproval. A superscript epsilon ( $\epsilon$ ) indicates an editorial change since the last revision or reapproval.

### 1. Scope

- 1.1 This is a fire-test-response standard.
- 1.2 Several fire-test-response characteristics, including the time to sustained flaming, heat release rate, total heat released, effective heat of combustion, and specific extinction area; are measured or calculated by this test method at a constant radiant heating flux. For specific limitations see also 5.7 and Section 6.
- 1.3 The tests are conducted by burning the electrical insulating materials contained in electrical or optical fiber cables when the cable test specimens, excluding accessories, are subjected to radiant heat.
- 1.4 *This standard measures and describes the response of materials, products, or assemblies to heat and flame under controlled conditions, but does not by itself incorporate all factors required for fire hazard or fire risk assessment of the materials, products or assemblies under actual fire conditions.*
- 1.5 The values stated in SI units are to be regarded as the standard. The values given in parentheses are for information only.
- 1.6 *This standard does not purport to address all of the safety concerns, if any, associated with its use. It is the responsibility of the user of this standard to establish appropriate safety and health practices and determine the applicability or regulatory limitations prior to use.* For specific precautionary statements, see Section 7.

### 2. Referenced Documents

- 2.1 *ASTM Standards:*
  - D 618 Practice for Conditioning Plastics for Testing<sup>2</sup>
  - D 1711 Terminology Relating to Electrical Insulation<sup>3</sup>
  - D 5424 Test Method for Smoke Obscuration of Insulating Materials Contained in Electrical or Optical Fiber Cables When Burning in a Vertical Cable Tray Configuration<sup>4</sup>
  - D 5485 Test Method for Determining the Corrosive Effect

- of Combustion Products Using the Cone Calorimeter<sup>4</sup>
- D 5537 Test Method for Heat Release, Flame Spread and Mass Loss Testing of Insulating Materials Contained in Electrical or Optical Fiber Cables When Burning in a Vertical Cable Tray Configuration<sup>4</sup>
- E 176 Terminology of Fire Standards<sup>5</sup>
- E 691 Practice for Conducting an Interlaboratory Study to Determine the Precision of a Test Method<sup>6</sup>
- E 906 Test Method for Heat and Visible Smoke Release Rates for Materials and Products<sup>5</sup>
- E 1354 Test Method for Heat and Visible Smoke Release Rates for Material and Products Using an Oxygen Consumption Calorimeter<sup>5</sup>
- E 1474 Test Method for Determining the Heat Release Rate of Upholstered Furniture and Mattress Components or Composites Using a Bench Scale Oxygen Consumption Calorimeter<sup>5</sup>
- 2.2 *CSA Standard:*
  - CSA C22.2 No. 0.3, FT4, Vertical Flame Tests: Cables in Cable Trays, Section 4.11.4 in C22.2 No. 0.3, Test Methods for Electrical Wires and Cables<sup>7</sup>
- 2.3 *IEC Standards:*
  - IEC 695-4 Fire Hazard Testing. Part 4: Terminology Concerning Fire Tests<sup>8</sup>
  - IEC 695-5-2 Fire Hazard Testing. Part 5: Guidance for Assessing Smoke Corrosivity from Burning of Electro-technical Products, Section 2: Test Methods<sup>8</sup>
- 2.4 *IEEE Standard:*
  - IEEE 1202: Standard for Flame Testing of Cables for Use in Cable Tray in Industrial and Commercial Occupancies, IEEE Standard 1202<sup>9</sup>
- 2.5 *ISO Standards:*

<sup>1</sup> This test method is under the jurisdiction of ASTM Committee D09 on Electrical and Electronic Insulating Materials and is the direct responsibility of Subcommittee D09.21 on Fire Performance Standards.

Current edition approved Sept. 10, 2002. Published October 2002. Originally published as D 6113 – 97. Last previous edition D 6113 – 99.

<sup>2</sup> *Annual Book of Standards*, Vol 08.01.

<sup>3</sup> *Annual Book of Standards*, Vol 10.01.

<sup>4</sup> *Annual Book of Standards*, Vol 10.02.

<sup>5</sup> *Annual Book of Standards*, Vol 04.07.

<sup>6</sup> *Annual Book of Standards*, Vol 14.02.

<sup>7</sup> Available from Canadian Standards Association, 178 Rexdale Blvd., Rexdale, Ontario, Canada, M9W 1R3.

<sup>8</sup> Available from International Electrotechnical Commission (IEC), 3 Rue de Varembe, Geneva, Switzerland.

<sup>9</sup> Available from Institute of Electrical and Electronic Engineers, 345 East 47th Street, New York, NY 10017.

ISO 13943 Fire Safety: Vocabulary<sup>10</sup>  
ISO CD 11907-4 Dynamic Method for Measuring Smoke  
Corrosivity Using a Radiant Conical Heater<sup>10</sup>

2.6 *NFPA Standard:*

NFPA 262 Standard Method of Test for Flame Travel and  
Smoke of Wires and Cables for Use in Air-Handling  
Spaces<sup>11</sup>

2.7 *OSHA Standard:*

OSHA 191.1450 Occupational Exposure to Hazardous  
Chemicals in Laboratories<sup>12</sup>

2.8 *UL Standards:*

ANSI/UL 910 Standard Test Method for Fire and Smoke  
Characteristics of Electrical and Optical Fiber Cables  
Used in Air Handling Spaces<sup>13</sup>

ANSI/UL 1581 Reference Standard for Electrical Wires,  
Cables, and Flexible Cords<sup>13</sup>

UL 1666 Standard Test for Flame Propagation Height of  
Electrical and Optical-Fiber Cables Installed Vertically in  
Shafts<sup>13</sup>

UL 1685 Standard Vertical Tray Fire Propagation and  
Smoke Release Test for Electrical and Optical Fiber  
Cables<sup>13</sup>

### 3. Terminology

3.1 *Definitions:*

3.1.1 For definitions of terms used in this test method and associated with fire issues use Terminology E 176, ISO 13943 and IEC 695-4. Where differences exist in definitions, those contained in Terminology E 176 shall be used. Use Terminology D 1711 for definitions of terms used in this test method and associated with electrical insulation materials.

3.2 *Definitions of Terms Specific to This Standard:*

3.2.1 *cone calorimeter, n*—the apparatus which is used in Test Method E 1354 to determine heat release rate, by the principle of oxygen consumption calorimetry, and other fire-test-response characteristics.

3.2.2 *effective heat of combustion, n*—the ratio of the measured heat release to the mass loss, under specified test conditions.

3.2.2.1 *Discussion*—The effective heat of combustion is a function of the test conditions, including heating flux, exposure time and test specimen geometry.

3.2.3 *heat release rate, n*—the calorific energy released per unit time by the combustion of a material under specified test conditions.

3.2.4 *heating flux, n*—the prescribed incident power per unit area of test specimen, the power being imposed externally from the heater onto the test specimen at the initiation of the test.

3.2.4.1 *Discussion*—The test specimen, once ignited, is also heated by its own flame.

3.2.5 *ignitability, n*—the measure of the ease with which a specimen can be ignited due to the influence of an external energy source, under specified test conditions.

3.2.6 *net heat of combustion, n*—the quantity of heat released by the complete combustion of a unit mass of the material, the water produced being in the vapor state.

3.2.7 *orientation, n*—the plane in which the exposed face of the test specimen is located during testing, which is horizontal facing up for this test.

3.2.8 *oxygen consumption principle, n*—the expression of the relationship between the mass of oxygen consumed during combustion and the heat released.

3.2.9 *smoke obscuration, n*—the reduction in visibility due to the smoke.

3.2.10 *specific extinction area, n*—a measure of smoke obscuration potential per unit mass lost, determined as the product of the extinction coefficient and the volumetric mass flow rate, divided by the mass loss rate.

3.2.11 *sustained flaming, n*—existence of flame on or over the surface of the test specimen for periods of 4 s or more.

3.2.11.1 *Discussion*—Flaming of less than 4 s duration is identified as flashing or transitory flaming.

3.2.12 *total heat released, n*—integrated value of the rate of heat release, for a specified time period.

### 4. Summary of Test Method

4.1 All fire-test-response characteristics in this test method are determined using the apparatus and procedures described in Test Method E 1354.

4.2 The oxygen consumption principle, used in this test method, is based on the observation that, generally, the net heat of combustion is directly related to the amount of oxygen required for combustion (1).<sup>14</sup> Approximately 13.1 MJ of heat are released per 1 kg of oxygen consumed. Test specimens in this test method are burned in ambient air conditions, while being subjected to a prescribed external heating flux. (See also X5.1).

4.3 The heat release is determined by the measurement of the oxygen consumption, as determined by the oxygen concentration and the flow rate in the combustion product stream, as described in Test Method E 1354.

4.4 The primary measurements are oxygen concentration and exhaust gas flow rate. Additional measurements include the time to sustained flaming, the smoke obscuration generated, the mass loss rate, and the effective heat of combustion. Ignitability is determined by measuring the time from initial exposure to time of sustained flaming of the test specimen.

4.5 A cone calorimeter is used to measure the consumption of oxygen during this test; heat release is then calculated, based on the oxygen consumption principle. The test specimen is mounted horizontally and a spark ignition source is employed.

### 5. Significance and Use

5.1 This test method is used to determine the heat release rate and a number of other fire-test-response characteristics as

<sup>10</sup> Available from International Organization for Standardization (ISO), PO Box 56, Geneva 20, CH 1211, Switzerland.

<sup>11</sup> Available from National Fire Protection Association (NFPA), 1 Batterymarch Park, Quincy, MA 02269-9101.

<sup>12</sup> Available from Occupational Health and Safety Administration, 200 Constitution Avenue NW, Washington, DC, 20210.

<sup>13</sup> Available from Underwriters Laboratories, Inc., 333 Pfingsten Rd, Northbrook, IL, 60062.

<sup>14</sup> The boldface numbers given in parentheses refer to a list of references at the end of this test method.

a result of exposing insulating materials contained in electrical or optical cables to a prescribed heating flux in the cone calorimeter apparatus.

5.2 Quantitative heat release measurements provide information that is potentially useful for design of electrical or optical cables, and product development.

5.3 Heat release measurements provide useful information for product development by giving a quantitative measure of specific changes in fire performance caused by component and composite modifications. Heat release data from this test method will not be predictive of product behavior if the product will not spread flame over its surface under the fire exposure conditions of interest.

5.4 The fire-test-response characteristics determined by this test method are affected by the thickness of the material used as test specimen, whether as a plaque or as coating on a wire or cable. The diameter of the wire or cable used will also affect the test results.

5.5 A radiant exposure is used as an energy source for this test method. This type of source has been used for comparison with heat release rate and flame spread studies of insulating materials constructed into cables when burning in a vertical cable tray configuration (Test Methods D 5424 and D 5537) (2-9). No definitive relationships have been established.

5.6 The value of heat release rate corresponding to the critical limit between propagating cable fires and non-propagating fires is not known.

5.7 This test method does not determine the net heat of combustion.

5.8 It has not been demonstrated that this test method is capable of predicting the response of electrical or optical fiber cables in a full scale fire. In particular, this test method does not address the self-extinguishing characteristics of the cables in a full scale fire.

## 6. Test Limitations

6.1 If during the test of one or more of the three replicate test specimens, any of the following unusual behavior occurs: molten material overflows the specimen holder trough; a test specimen is displaced from the zone of controlled irradiance (explosive spalling); or the test specimen swells sufficiently prior to ignition to touch the spark plug or swells up to the plane of the heater base during combustion; then test an additional specimen of the identical preconditioned test specimens in the test mode in which the unusual behavior occurred. Do not incorporate data obtained from the tests noted above, yielding inadequate results, in the averaged data but report the occurrence. This test method is not suitable if more than three out of six test specimens tested show any of the above characteristics.

6.2 The applicability of this test method to smoldering ignition of cables has not been demonstrated. This test method is not suitable for incident heat fluxes below 10 kW/m<sup>2</sup>.

6.3 The validity of the results of this test method for a particular scenario depends on the conditions under which the tests are conducted. In particular, it has been established that the use of a different heating flux will change relative results.

## 7. Safety Precautions

7.1 The test procedures involve high temperatures and combustion processes. Hazards therefore exist for burns, ignition of extraneous objects or clothing, and inhalation of combustion products. The operator must take appropriate precautions during the insertion and removal of the test specimens, for example, by using protective gloves. Do not touch either the cone heater or the associated fixtures while hot, except with the use of appropriate protective gear.

7.2 Vent the combustion products flowing through the exposure chamber through a properly designed exhaust system. An adequate method of venting the combustion products captured in the exposure chamber during the test is through an OSHA approved smoke hood<sup>15</sup> at the end of a test.

7.3 Check the exhaust system for proper operation before testing and discharge into a building exhaust system with adequate capacity. Make provisions for collecting and venting any combustion products that for whatever reason are not collected by the exhaust system of the apparatus.

## 8. Test Specimen

### 8.1 Size and Preparation:

8.1.1 The types of test specimens permitted are (a) materials in the form of a flat plaque, or (b) electrical insulating materials contained in electrical or optical cables. The test specimen shall be 100 ± 2 by 100 ± 2 mm (approximately 4 ± 0.08 by 4 ± 0.08 in.) in size, or as close to that as possible. Fill the specimen holder as completely as possible with the cable pieces. Make the thickness of a material test specimen in a flat plaque the same as that of the end use of the material in cable construction. If the end use thickness is not known, or if the test is conducted for other purposes, use a thickness of 6.3 ± 0.5 mm (approximately 0.25 ± 0.02 in.). Ensure that the overall characteristics of the test specimens are those of the wire or cable in its end use (wall thickness and overall diameter).

NOTE 1—Overall test specimen thicknesses of less than 2 mm (approximately 0.08 in.) are not recommended, because potential testing errors become larger.

8.1.2 For test specimens of materials in flat plaques, cut the test specimen to a size of 100 ± 2 by 100 ± 2 mm (approximately 4 ± 0.08 by 4 ± 0.08 in.). Wrap the test specimen in a single layer of aluminum foil (0.03 to 0.04 mm (1.2 to 1.6 × 10<sup>-3</sup> in.) thick), shiny side towards the test specimen. Place the edge frame over the test specimen and cut the aluminum foil along the open edges at the top of the edge frame to expose the test specimen. Remove the test specimen from the edge frame, place a grid on the exposed face of the test specimen and insert both the test specimen and the grid into the edge frame.

8.1.3 For test specimens of electrical insulating materials contained in electrical or optical fiber cables, cut the cables to 100 ± 2 mm (approximately 4 ± 0.08 in.) lengths to fill the

<sup>15</sup> Use a smoke hood in compliance with OSHA regulations for Occupational Exposure to Hazardous Chemicals in Laboratories - 191.1450.

specimen holder. Seal the ends using an adhesive cement.<sup>16</sup> Apply the adhesive cement to the cable ends such that there are no visible air holes in the coating and that the cement does not overlap the cable ends. Wrap the cable lengths in a single layer of aluminum foil. Place the edge frame over the cable test specimens and cut the aluminum foil along the open edges at the tip of the edge frame and expose the test specimens. Remove the test specimens from the edge frame, place a grid on the exposed face of the test specimens and insert both the test specimen and the grid into the edge frame.

8.1.4 Optionally, for test specimens of electrical insulating materials contained in electrical or optical fiber cables, cut the cables to  $100 \pm 2$  mm (approximately  $4 \pm 0.08$  in.) lengths to fill the specimen holder, without sealing the ends. Wrap the cable lengths in a single layer of aluminum foil. Place the edge frame over the cable test specimens and cut the aluminum foil along the open edges at the tip of the edge frame and expose the test specimens. Remove the test specimens from the edge frame, place a grid on the exposed face of the test specimens and insert both the test specimen and the grid into the edge frame.

NOTE 2—The objective of sealing the cable ends is to prevent gas evolution through such ends, that is not to be expected when a full length of cable is exposed to a fire in actual use. Moreover, the same method of test specimen preparation is used in Test Method D 5485, and the draft international test method ISO CD 11907-4, mentioned in IEC 695-5-2. However, it is unclear whether the results of the cone calorimeter testing are more meaningful with the cable ends sealed or unsealed.

8.2 Condition the test specimens in accordance with Practice D 618 to moisture equilibrium (constant weight) at an ambient temperature of  $23 \pm 3^\circ\text{C}$  and a relative humidity of  $50 \pm 5\%$ .

### 8.3 Specimen Holder and Mounting:

8.3.1 A specimen holder consists of the bottom, the edge frame, retaining pins and wire grid as shown in Fig. 1. The bottom is constructed from 2 mm nominal stainless steel and has outside dimensions of 111 by 111  $\pm 2$  by 24  $\pm 2$  mm height. The grid is constructed from 1 mm nominal stainless steel and has dimensions of 109  $\pm 2$  by 109  $\pm 2$  mm. The grid has 1 mm ribs and the openings in the center are 19  $\pm 1$  by 19  $\pm 1$  mm. The edge frame is constructed from 2 mm nominal stainless steel with outside dimensions of 116  $\pm 2$  by 116  $\pm 2$  by 56  $\pm 2$  mm height. The frame has an 8 mm lip on the top to provide an opening of 100 by 100 mm on the top. There are two 3  $\pm 0.5$  mm diameter by 130  $\pm 3$  mm long retaining pins to lock the test specimen in the edge frame.

8.3.2 The bottom is lined with a layer of a low density (nominal density 65 kg m<sup>-3</sup>) ceramic fiber refractory blanket with thickness of at least 13 mm. If necessary, fill the edge frame below the test specimens with refractory blanket to the level of the retaining pins. Lock the assembly with retaining pins and place assembly on the bottom specimen holder. The distance between the bottom of the radiant heater and the top of the edge frame is adjusted to  $25 \pm 1$  mm by using a sliding height adjustment.

## 9. Procedure

### 9.1 Preparation:

9.1.1 Calibrate the test apparatus in accordance with Test Method E 1354. Position the cone heater for a horizontal specimen orientation and set the radiant heating flux level to the chosen value, with a tolerance of  $\pm 1$  kW/m<sup>2</sup>.

9.1.2 Verify that the distance between the bottom of the cone heater baseplate and the top of the test specimen is 25 mm (approximately 1 in.).

9.1.3 Position the spark igniter at a distance of 13 mm above the test specimen surface.

NOTE 3—As stated in 6.1, if the test specimen comes in contact with the spark igniter or the heater base plate, the test results will not be usable.

### 9.2 Procedure:

9.2.1 Prepare the data collection system for testing in accordance with the operating procedures for the system in Test Method E 1354. Place the test specimen in the specified holder on the load cell and start data collection. The holder must be at room temperature initially. The data collection intervals shall not exceed 5 s.

9.2.2 Energize the spark igniter and move it into place as rapidly as possible after test specimen insertion.

9.2.3 Start the timer at the beginning of the test. After flaming is first observed, continue the observation for an additional 4 s. At that point record the time and move the spark igniter out of the flame. Determine the time to flaming ignition. Note that the time to ignition is the time for sustained flaming to start; therefore, if the timer is stopped at the end of the 4 s observation period, the time to be reported is that value, minus 4 s.

NOTE 4—If flaming combustion is not observed, report as “No Ignition was Observed” and not as “Time to Ignition Equals Zero”.

9.2.4 Collect data from the start of the test until the first of the following criteria has been reached: average mass loss over a 1-min period has dropped below 1.5 g or 60 min have elapsed. Ensure that the minimum test period is 30 min.

9.2.5 Observe and record physical changes to the test specimen, such as melting, swelling, and cracking.

9.2.6 Remove the specimen holder.

9.2.7 Replace with an empty specimen holder or insulated pad to prevent thermal damage to the load cell.

9.2.8 Test three test specimens under each condition.

## 10. Calculation

10.1 Use the calculation procedures from Test Method E 1354 for all fire-test-response characteristics.

10.2 Calculate the total heat release per unit area (in kW/m<sup>2</sup>), average specific extinction area (in m<sup>2</sup>/kg) and the effective heat of combustion (in MJ/kg) by using data over the entire period indicated in 9.2.4, beginning with the next reading after the last (if any) negative heat release rate reading at the beginning of the test.

NOTE 5—Certain test specimens do not show visible, sustained flaming but do indicate non-zero heat release or smoke obscuration values.

10.3 Calculate the average mass loss rate (in g/s) over the period starting at the time when 10 % of the ultimate test specimen mass loss occurred and ending at the time when 90 %

<sup>16</sup> Adhesive cement, Sauereisen Insa-Lute, available from Sauereisen, 160 Gamma Drive, Pittsburgh, PA 15238, or from Fischer Scientific (Catalog number 04-760-15), is suitable for this application.

**ASTM D 6113 – 02**

MATERIAL:

STAINLESS 1.84mm THICK

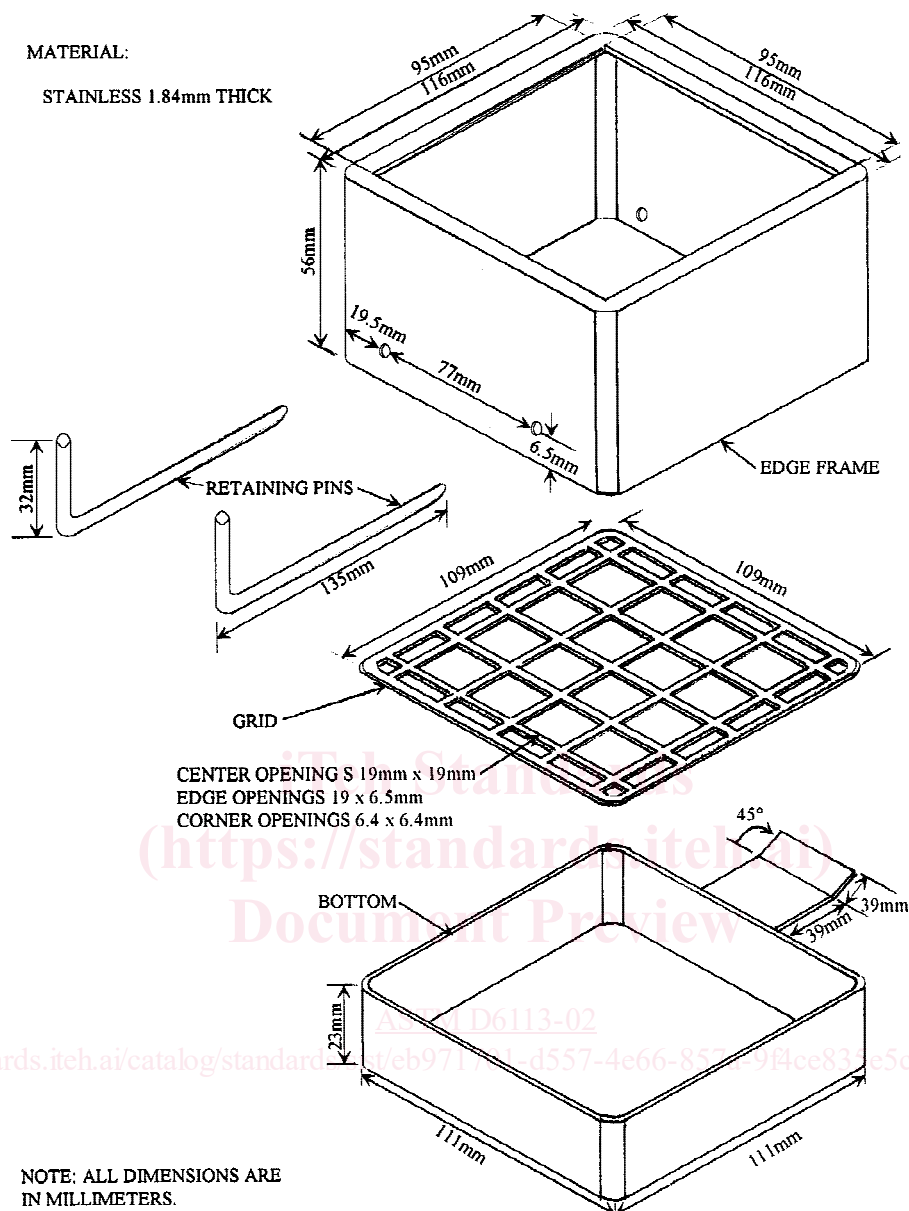

**FIG. 1 Specimen Holder**

of the ultimate test specimen mass loss occurred.

NOTE 6—This is done in order to get more consistent results.

NOTE 7—For certain materials the mass loss is not representative of the fraction of the test specimen that has burnt. For silicone materials, for example, combustion results in solid residues of products of silicon oxidation, with higher mass than the original test specimen.

**11. Report**

11.1 Report the following information, as a summary, for all test specimens of a particular material or product:

- 11.1.1 Test specimen identification or number,
- 11.1.2 Manufacturer or submitter,
- 11.1.3 Date of test,
- 11.1.4 Composition or generic identification, and
- 11.1.5 Details of preparation.

11.2 Include the following information for each test specimen:

**TABLE 1 Results of Inter-Laboratory Trials for Test Method E 1354<sup>A</sup>**

Property	TTI	Pk RHR	Avg RHR	THR	EHC	SEA
Units	s	kW/m <sup>2</sup>	kW/m <sup>2</sup>	MJ/m <sup>2</sup>	MJ/kg	m <sup>2</sup> kg
Range	5 to 150	70 to 1120	70 to 870	5 to 720	7 to 40	30 to 2200
<i>r</i>	...	...	...	...	...	...
A	4.1	13.3	23.3	7.4	1.23	59.0
B	0.125	0.131	0.037	0.068	0.050	0.076
<i>R</i>	...	...	...	...	...	...
A	7.4	60.4	25.5	11.8	2.42	63.0
B	0.220	0.141	0.151	0.088	0.055	0.215

<sup>A</sup> Abbreviations used: TTI: time to sustained flaming; Pk RHR: maximum heat release rate; Avg RHR: average heat release rate in the 180 s following ignition; THR: total heat released; EHC: effective heat of combustion; range: range of results obtained in the inter-laboratory evaluation; SEA: average specific extinction area.

11.2.1 Test specimen thickness (mm),

- 11.2.2 Test specimen initial mass, measured on the load cell (g),
- 11.2.3 If the test specimen is in the form of electrical insulating materials contained in electrical or optical cables, the number of lengths of cable, and the diameter of the cable,
- 11.2.4 Heating flux and initial exhaust system flow rate,
- 11.2.5 Time to sustained flaming (s),
- 11.2.6 Curve of heat release rate versus time,
- 11.2.7 Average heat release rate for the first 180 s after ignition (kW/m<sup>2</sup>),
- 11.2.8 Peak heat release rate (kW/m<sup>2</sup>),
- 11.2.9 Total heat released by the test specimen per unit area for entire test (MJ/m<sup>2</sup>),
- 11.2.10 Average effective heat of combustion for entire test (MJ/kg),
- 11.2.11 Average specific extinction area for entire test (m<sup>2</sup>/kg),
- 11.2.12 Mass remaining at test termination (g),
- 11.2.13 Test specimen mass loss (g),
- 11.2.14 Average test specimen mass loss rate for entire test (g/s),
- 11.2.15 Additional observations, if any, and
- 11.2.16 Difficulties encountered in testing, if any.
- 11.3 Average the following final values for all test specimens:
  - 11.3.1 Time to sustained flaming (s),
  - 11.3.2 Average heat release rate value (kW/m<sup>2</sup>) over the first 180 s after ignition,
  - 11.3.3 Average effective heat of combustion (MJ/kg) for the entire test. This is obtained by dividing the total heat released by the test specimen mass loss,
  - 11.3.4 Peak heat release rate (kW/m<sup>2</sup>),
  - 11.3.5 Total heat released (MJ/m<sup>2</sup>),
  - 11.3.6 Average specific extinction area (m<sup>2</sup>/kg),
  - 11.3.7 Test specimen mass loss (g), and
  - 11.3.8 Average test specimen mass loss rate (g/s).

**12. Precision and Bias**

**12.1 Precision:**

12.1.1 The precision of test measurements using the cone calorimeter for materials as flat plaques, in accordance with Test Method E 1354, has been determined by inter-laboratory trials conducted by ASTM Committee E-5 on Fire Standards. The fire-test-response characteristics chosen for determining repeatability and reproducibility were: time to sustained flaming, peak heat release rate, average heat release rate over the

first 180 s after ignition, the total heat released, the effective heat of combustion and the average specific extinction area. The results were expressed in terms of an equation such as:

$$r \text{ (or } R) = A + B * \text{Property} \tag{1}$$

where:

- r* = intra-laboratory repeatability;
- R* = inter-laboratory reproducibility;
- Property = fire-test-response characteristic considered and *A* and *B* are constants.

12.1.2 Results of tests on plaque specimens for the materials test are shown in Table 1.<sup>17</sup>

12.1.3 An interlaboratory evaluation, using 4 laboratories, was conducted to assess the precision of the procedure for measuring the heat release rate and other fire-test-response characteristics of electrical insulating materials contained in electrical or optical fiber cables using the cone calorimeter. The specimens used were: a flat plaque of an electrical insulating material and four cables, and were described as follows.

12.1.3.1 Plaque P1: a non commercial poly(vinyl chloride) wire and cable type compound, at a thickness of 6 mm.

12.1.3.2 Cable C1: a cable with a white jacket and an outer diameter of 5 mm, with 4 pairs of 24AWG insulated copper conductors. The wire insulation and outer jacket are polyolefin compounds containing no halogens.

12.1.3.3 Cable C2: a plenum rated (CMP) telephone cable with a blue jacket and an outer diameter of 4 mm, with 4 pairs of 24 AWG solid insulated copper conductors. The wire insulation is fluorinated ethylene propylene and the outer jacket is fire retarded poly(vinyl chloride).

12.1.3.4 Cable C3: a riser rated (CMR) inside telephone switchboard cable with a grey jacket and an outer diameter of 9 mm, with 25 pairs of 24 AWG solid bare copper conductors. The wire insulation and outer jacket are fire retarded poly(vinyl chloride).

12.1.3.5 Cable C4: a vertical tray rated (CM) Type TC control with a black jacket and an outer diameter of 15 mm, with 9 solid insulated 12 AWG copper conductors. The wire insulation is poly(vinyl chloride)/nylon insulation and the outer jacket is poly(vinyl chloride).

12.1.4 Tables 2-7 contain the statistical information on precision for repeatability and reproducibility for the following properties: time to sustained flaming, peak heat release rate,

<sup>17</sup> Supporting data are available from ASTM Headquarters. Request RR: E05-1008.

**TABLE 2 Intralaboratory and Interlaboratory Precision Results of Round Robin Evaluation: Time to Sustained Flaming (s)**

Material	Heat Flux (kW/m <sup>2</sup> )	Average	STD repeat	STD Repro	r	R	RSD repeat	RSD Repro
Plaque P1	50	22.4	3.7	3.7	10	10	16.4	16.4
Plaque P1	25	105.0	1.0		3		1.0	
Cable C1	50	37.2	6.2	6.2	17	17	16.7	16.7
Cable C1	25	236.3	17.2		48		7.3	
Cable C2	50	106.5	65.4	65.4	183	183	61.4	61.4
Cable C2	25	10000.0	0.0		0		0.0	
Cable C3	50	39.8	12.5	12.5	35	35	31.3	31.3
Cable C3	25	251.0	9.8		28		3.9	
Cable C4	50	47.6	6.4	23.9	18	67	13.4	50.3
Cable C4	25	232.1	120.3	120.3	337	337	51.8	51.8
Average Values			24	39			20	38