



Standard Test Method for Measurement of Glass Stress—Optical Coefficient¹

This standard is issued under the fixed designation C 770; the number immediately following the designation indicates the year of original adoption or, in the case of revision, the year of last revision. A number in parentheses indicates the year of last reapproval. A superscript epsilon (ϵ) indicates an editorial change since the last revision or reapproval.

1. Scope

1.1 This test method covers procedures for determining the stress-optical coefficient of glass, which is used in photoelastic analyses. In Procedure A the optical retardation is determined for a glass fiber subjected to uniaxial tension. In Procedure B the optical retardation is determined for a beam of glass of rectangular cross section when subjected to four-point bending. In Procedure C, the optical retardation is measured for a beam of glass of rectangular cross-section when subjected to uniaxial compression.

1.2 *This standard does not purport to address all of the safety concerns, if any, associated with its use. It is the responsibility of the user of this standard to establish appropriate safety and health practices and determine the applicability of regulatory limitations prior to use.*

2. Referenced Documents

2.1 ASTM Standards:

- C 336 Test Method for Annealing Point and Strain Point of Glass by Fiber Elongation²
- C 598 Test Method for Annealing Point and Strain Point of Glass by Beam Bending²
- F 218 Test Method for Analyzing Stress in Glass³

3. Significance and Use

3.1 Stress-optical coefficients are used in the determination of stress in glass. They are particularly useful in determining the magnitude of thermal residual stresses for annealing or pre-stressing (tempering) glass. As such, they can be important in specification acceptance.

4. Apparatus

4.1 Stressing Equipment and Polarimeter:

4.1.1 *Procedure A*— Figs. 1 and 2 illustrate a polarimeter employing a quarter-wave plate and rotatable analyzer,⁴ described in Test Method F 218. The quarter-wave plate shall be

designed for the wavelength of the light being used. The polarizing axes of the polarizer and analyzer shall be set at right angles to each other with each being located at an angle of 45° with the horizontal and vertical. The analyzer, however, shall be mounted in a rotatable mount having a scale graduated on either side from 0 to 180°. The quarter-wave plate shall be fixed to give maximum extinction when the polarizer and analyzer are crossed at right angles; that is, when its polarizing axes are set at 45° and 135° to the horizontal and vertical. In place of the immersion cell *E*, a means of supporting and loading a glass specimen shall be provided, either in air (Fig. 3(a)) or in an immersion liquid (Fig. 3(b)). In this arrangement the optical elements of the polarimeter between light source and telescope have been reversed and a large scale graduated in 2-nm divisions is employed with the rotatable analyzer *I*.

4.1.1.1 Fig. 3 illustrates the fiber-stressing and optical arrangement used in Procedure A. Figure 3(a) shows the fiber mounted vertically, positioned, and supported by two brass collars with swivel handles so that the kilogram weight may be applied to load the fiber. A light shield having entrance and exit slits surrounds the fiber providing a degree of collimation to the light passing through the fiber and also helping to eliminate stray light.

4.1.1.2 In Fig. 3(b) the fiber is stressed while immersed in a liquid which matches the refractive index of the fiber. This arrangement provides more satisfactory viewing of the fiber.

4.1.2 *Procedure B*:

4.1.2.1 The apparatus for the beam-bending procedure is shown in Fig. 4(a). Radiation from a white-light source passes through the following components and in this sequence: a diffusing plate, an adjustable aperture, a polarizer whose axis is at 45° to the vertical, the glass specimen, a Babinet compensator, a polarizer whose axis is at 90° to that of the first polarizer, and a telescope of modest power.

4.1.2.2 The loading scheme is shown in Fig. 4(b). Metal fixtures shall be provided to subject the specimen to four-point bending. A support span of 115 mm and a moment arm, *a*, of 45 mm are recommended. Dimensions within 5 % of these values are acceptable. Symmetrical loading is essential, and requires careful centering of the upper loading block. The knife edges shall be finished to approximately 5-mm radius. Loading can be accomplished through a yoke, which rests in a V-groove in the upper loading block, and a weight pan as shown. However, any convenient loading scheme at the center of the upper block may be used.

¹ This test method is under the jurisdiction of ASTM Committee C-14 on Glass and Glass Products and is the direct responsibility of Subcommittee C14.04 on Physical and Mechanical Properties.

Current edition approved Oct. 10, 1998. Published January 1999. Originally published as C 770 – 73 T. Last previous edition C 770 – 95.

² *Annual Book of ASTM Standards*, Vol 15.02.

³ *Annual Book of ASTM Standards*, Vol 10.04.

⁴ Goranson and Adams, "Measurement of Optical Path Differences," *Journal of Franklin Institute*, Vol 216, 1933, p. 475.

ASTM C 770

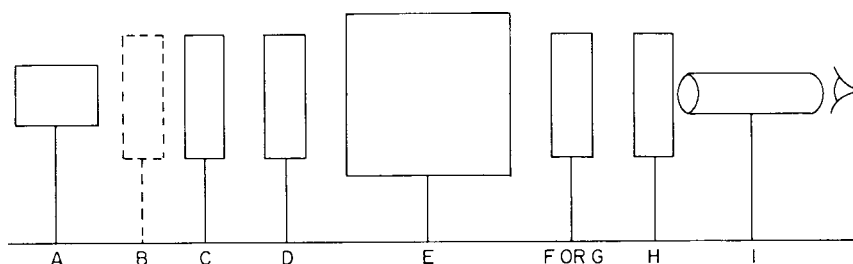

FIG. 1 Polarimeter

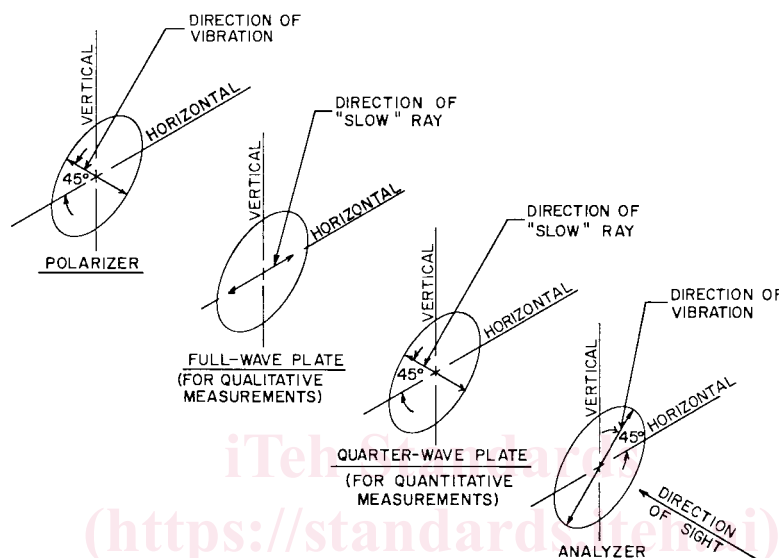

FIG. 2 Orientation of Polarimeter in Standard Position

4.1.2.3 A Babinet compensator is positioned so as to produce vertical fringes (Fig. 4(c)). The neutral fringe must fall near the center of the support span. Recommended fringe spacing is 1000 ± 200 nm of retardation per centimeter. In actual practice the compensator is placed very close to the specimen inside the loading yoke.

4.1.2.4 A telescope is mounted in a rotating collar equipped with an angular scale which can be read to 0.1° by a vernier. The cross hairs in the eyepiece are used to measure the tilt angle of the neutral fringe as shown in Fig. 4(c). An 80-mm objective lens and $10\times$ eyepiece are adequate components for the telescope.

4.1.2.5 The adjustable aperture is set at the smallest diameter that permits suitable viewing. As with the fiber apparatus, this provides some collimation and helps to eliminate stray light.

4.1.3 Procedure C:

4.1.3.1 Polarimeter as described in Test Method F 218.

4.1.3.2 Force application frame, shown in Fig. 5 must include:

- a) A strain-gage load cell and load cell indicator, capable of measuring the force applied within 1 % accuracy.
- b) Hydraulic or mechanical means of applying constant force and maintaining the force during the measuring time.
- c) Swivel-mounted loading blocks, offering at least two degrees of swivel freedom, to avoid the loading on the edge.

4.2 *Micrometer Caliper*, for measuring specimen dimensions to 0.0025 mm (0.0001 in.).

4.3 *Weights* that are known to an accuracy of ± 1 %.

5. Test Specimen

5.1 Procedure A:

5.1.1 Select a mass of the glass to be tested that has good optical quality with no heavy cords or striae. By conventional lamp-working methods, draw 0.6 to 0.9 m (2 to 3 ft) of fiber from the glass, sufficient to provide five specimens 76 to 102 mm (3 to 4 in.) long with taper (variation in diameter along the length) less than 0.025 mm (0.001 in.) and diameters in the range 0.635 mm (0.025 in.) to 0.760 mm (0.030 in.). The difference in mutually perpendicular diameters at any point along the specimen length shall be less than 0.0076 mm (0.0003 in.).

5.1.2 Bead both ends of each specimen by holding the end in a flame with the fiber vertical until a bead of two to three fiber diameters forms.

5.1.3 Anneal the specimens together so as to remove most of the lamp-working stress (Annex A2).

5.2 Procedure B:

5.2.1 Select a mass of glass to be tested that has good optical quality with no heavy cords or striae. By conventional grinding methods, prepare a beam of rectangular cross section. The width of the beam shall be within the range 20 to 30 mm (0.8 to 1.2 in.), the thickness within the range 6 to 10 mm (0.25 to 0.40 in.), and the length within the range 120 to 130 mm (4.75 to 5.10 in.). Use a fine grind for the upper and lower surfaces (as the beam sits on the loading fixture) and polish the viewing

ASTM C 770

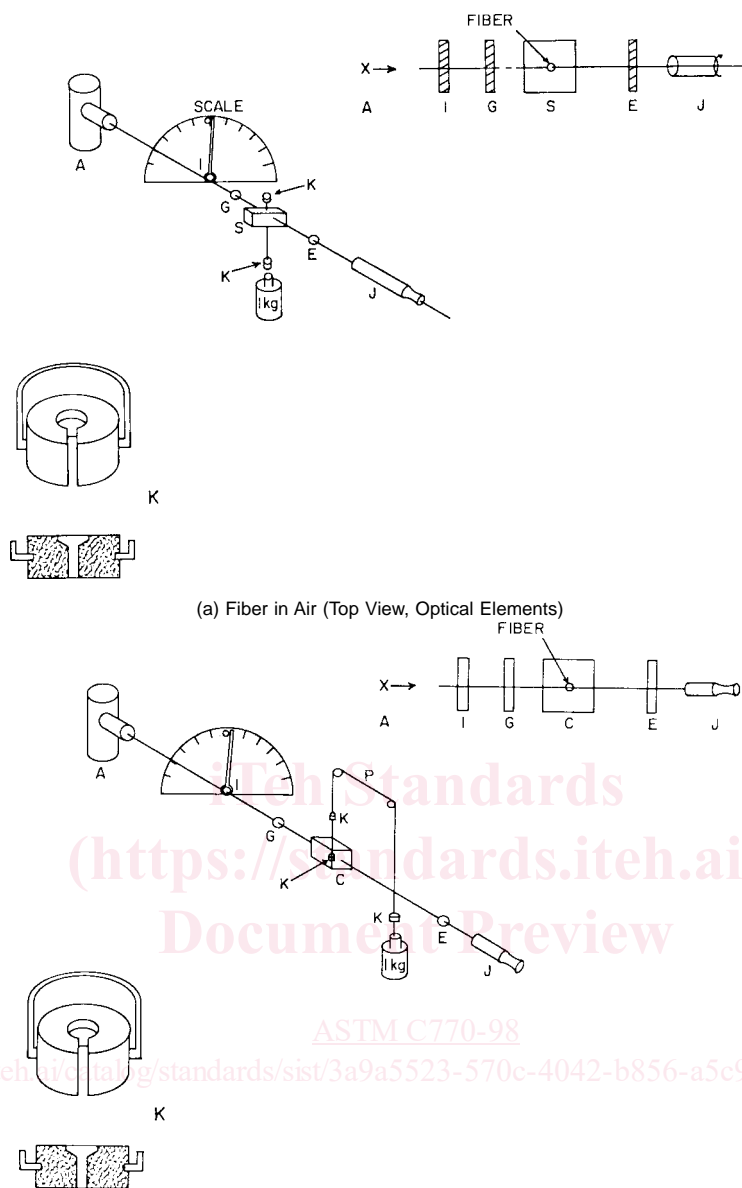

(a) Fiber in Air (Top View, Optical Elements)

(b) Fiber Immersed

A—Light Source
 C—Optical cell and index liquid
 E—Polarizer
 G—Quarter-wave plate
 I—Rotatable analyzer

J—Telescope
 K—Brass collars
 P—Pulley system
 S—Shield and slits

FIG. 3 Optical and Fiber-Stressing Polarimeter Arrangement

surfaces. The ends need not be finished and a simple saw cut will suffice. The four major surfaces shall be flat and parallel to within 0.050 mm (0.002 in.).

5.2.2 Before final finishing, fine anneal the glass (Annex A2) to such a degree that when the specimen is placed in the fixture unloaded there is very little curvature to the portion of the neutral fringe that appears within the specimen.

5.3 Procedure C:

5.3.1 The thickness of the specimen (see Fig. 6) should be no less than 5 mm ($\frac{3}{16}$ in.).

5.3.2 The width should be no less than 10 mm ($\frac{3}{8}$ in.).

5.3.3 The length of the specimen should be larger than 4×

width, but not longer than 60× thickness, to avoid buckling failures.

5.3.4 Both ends must be ground flat and parallel, within 0.1 mm (0.004 in.).

6. Procedure

6.1 Procedure A:

6.1.1 Mount the fiber specimen vertically by the beaded end in the test fixture so that approximately the midlength is in the polariscope light beam and the fiber image is clearly in focus.

6.1.2 Adjust the light shield or aperture so that the slits are