



Designation: A 698/A 698M – 02

Standard Test Method for Magnetic Shield Efficiency in Attenuating Alternating Magnetic Fields¹

This standard is issued under the fixed designation A 698/A 698M; the number immediately following the designation indicates the year of original adoption or, in the case of revision, the year of last revision. A number in parentheses indicates the year of last reapproval. A superscript epsilon (ϵ) indicates an editorial change since the last revision or reapproval.

1. Scope

1.1 This test method provides means for determining the performance quality of a magnetic shield when placed in a magnetic field of alternating polarity.

1.2 This test method provides means for establishing the desired value of alternating magnetic field strength, of suitable uniformity, inside a standard test coil.

1.3 This test method provides tests for determining the strength of the alternating magnetic field inside the standard coil.

1.4 This test method provides tests for determining the attenuation of the established alternating magnetic field due to the insertion of a magnetic shield around the point of measurement.

1.5 This test method shall be used in conjunction with and shall conform to the requirements of Practice A 34/A 34M.

1.6 The values and equations stated in customary (cgs-emu and inch-pound) or SI units are to be regarded separately as standard. Within this test method, SI units are shown in brackets. The values stated in each system may not be exact equivalents; therefore, each system shall be used independently of the other. Combining values from the two systems may result in nonconformance with the test method.

1.7 *This standard does not purport to address all of the safety concerns, if any, associated with its use. It is the responsibility of the user of this standard to establish appropriate safety and health practices and determine the applicability of regulatory limitations prior to use.*

2. Referenced Documents

2.1 ASTM Standards:

A 34/A 34M Practice for Sampling and Procurement Testing of Magnetic Materials²

A 340 Terminology of Symbols and Definitions Relating to Magnetic Testing²

¹ This test method is under the jurisdiction of ASTM Committee A06 on Magnetic Properties and is the direct responsibility of Subcommittee A06.01 on Test Methods.

Current edition approved Oct. 10, 2002. Published November 2002. Originally published as A 698 – 74. Last previous edition A 698 – 92 (1997)¹.

² *Annual Book of ASTM Standards*, Vol 03.04.

3. Terminology

3.1 The following symbols and abbreviated definitions apply only to this test method (the official symbols and definitions are listed in Terminology A 340):

3.2 *attenuation ratio*—the ratio of the measured voltage in the pickup coil before and after the insertion of the shield under test, E_1/E_2 .

3.3 A —ac ammeter (usually root mean square (rms) but may be peak reading type).

3.4 E_1 —voltage in the pickup coil, after establishing the field of test but before insertion of the shield into the test position.

3.5 E_2 —highest voltage observed in the pickup coil, at the field of test, while rotating the test shield in the test position.

3.6 H_p —magnetic field strength, Oe [A/m].

3.7 I_p —ac magnetizing current, peak amperes.

3.8 I —ac magnetizing current, rms amperes.

3.9 l_c —length of demagnetizing air coil, cm [m].

3.10 N —number of turns per coil section (one half of total Helmholtz coil turns).

3.11 N_1 —number of turns in demagnetizing coil.

3.12 R —mean radius of Helmholtz coil, cm [m].

3.13 V —electronic voltmeter (average volts $\times \pi/2 \sqrt{2}$).

4. Summary of Test Method

4.1 *Frequency*—Tests under this test method are normally conducted at a test frequency of 60 Hz.

NOTE 1—Other test frequencies are used by mutual agreement. In general, as test frequencies are increased, it will be necessary to make corresponding changes in pickup or test coils and in the size of the power supply.

4.2 *Magnetic Field Strength*—Tests may be conducted at any desired magnetic field strength. The standard test level for ac magnetic fields is 0.5 or 2.0 peak Oe [40 or 160 peak A/m] and in the presence of the earth's magnetic field (see 9.2).

4.3 *Instrumentation*—The instruments described are for use at 60 Hz. At higher frequencies, electronic voltmeters and preamplifiers should also be satisfactory. It may be necessary to change the rms ammeter and power supplies for use at higher test frequencies. It may also be desirable to reduce the number of area turns in the pickup coil at these frequencies.

4.4 *Field Attenuation*—The usable range of attenuation ratios is determined by the strength of the starting field and the sensitivity of the available instrumentation. Measurements shall not be made when signal voltages cannot be clearly distinguished from amplifier noise or other transient voltages.

5. Significance and Use

5.1 This test method provides an easy, accurate, and reproducible method for determination of shielding factors (attenuation ratios) in simple alternating magnetic fields.

5.2 Since the sensing or pickup coil is of finite size, the measured shielding factor tends to be the average value for the space enclosed by the coil. Due care is required when interpreting results when the coil is located near an opening in the shield.

5.3 This test method is suitable for design, specification acceptance, service evaluation, quality assurance, and research purposes.

6. Apparatus

6.1 *Helmholtz Coil:*

6.1.1 The standard Helmholtz coil shall have an inside diameter of 48 in. [1.22 m]. It shall consist of two identical coil sections of 48 turns each, wound on separate forms that are rigidly fastened together or as two separate 48-turn coils wound on a single cylindrical form. The frame shall be constructed of nonmagnetic materials. A satisfactory wire size is No. 14 varnish-insulated copper wire wound into concentrated multi-layer coils of approximately square cross section. **The two coils shall be mounted to have a common axis with the spacing between coil centers equal to the coil radius.** The electrical connections between coil sections shall be such that they are connected in series with their fields aiding to form the Helmholtz coil (Figs. 1 and 2).

6.1.2 The standard Helmholtz coil will measure shields up to 16 in. [0.40 m] in length and 12 in. [0.30 m] in diameter. If

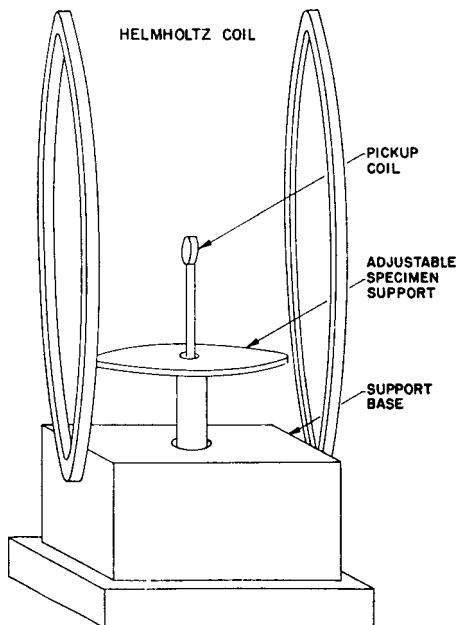

FIG. 1 Shield Testing Apparatus

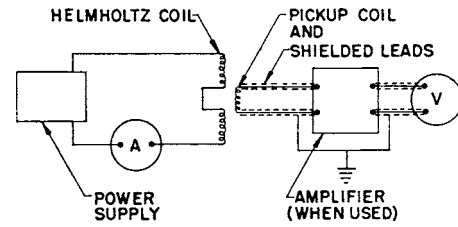

FIG. 2 Diagram of Connections for the Shield Test

larger shields are to be measured, the Helmholtz coil diameter shall be at least three times the length of the test specimen or four times its diameter, or both. By mutual agreement, small specimens may be measured in smaller Helmholtz coils providing the ratio of coil to specimen sizes described above is maintained. The framework shall be constructed to allow easy access for insertion of the shield test specimen. The pickup coil should be fastened to a support that maintains its position and orientation at the center of the Helmholtz coil system. The test fixture also requires an adjustable specimen support that permits perpendicular positioning in relation to the axis of the coil and permits 360° rotation. Also the test fixture shall be equipped with a centering adjustment which holds the shield specimen in place at the center of the Helmholtz coil system during the test. The axis of the test specimen shall be 90° to the direction of the field. No magnetic material shall be used in the construction of the test apparatus, and the use of electrically conducting materials should also be avoided wherever possible.

6.2 *Pickup Coil*—The pickup coil shall be wound to have a value of area turns that is adequate to provide sufficient voltage for good instrument scale deflections when the coil is in the weakest field to be measured. In general, for broad-range requirements, the pickup coil should have an area turns product of approximately 50 000-cm² turns. For best reproducibility, the coil should be covered with a thin nonmagnetic electrically conductive foil shield (copper, aluminum, and so forth) which should be connected to the system common point or to ground. Care must be taken to make sure the edges of this shield material are insulated in such a manner as to prevent a shorted turn effect around the flux linking the coil area. Coil leads to the instrument shall be enclosed in a grounded electrostatic shield which may also be connected to the foil of the coil shield. The pickup coil should be positioned at the center of the Helmholtz coil, equidistant from the two coil sections, and oriented so its axis coincides with that of the Helmholtz coil. Either or both the diameter and length of the pickup coil shall be equal to or less than one half of the diameter of the shield test specimen and should be less than one tenth of the Helmholtz coil radius. The pickup coils listed in Table 1 are recommended for use with various size shields.

TABLE 1 Suggested Pickup Coils

Pickup Coil Number	Wire Size No.	Number of Turns	Approximate Dimensions	
			Length, in. [mm]	Mean Diameter, in. [mm]
1	40	10 000	1.0 [25.4]	1.0 [25.4]
2	40	20 000	1.25 [31.8]	1.25 [31.8]