

INTERNATIONAL  
STANDARD

ISO  
7619

Second edition  
1997-04-15

---

---

**Rubber — Determination of indentation  
hardness by means of pocket hardness  
meters**

**iTeh STANDARD PREVIEW**

**(standards.iteh.ai)**

*Caoutchouc — Détermination de la dureté par pénétration au moyen d'un  
duromètre de poche*

ISO 7619:1997

<https://standards.iteh.ai/catalog/standards/sist/6f6d37bd-de1c-45cc-a7ae-9ec7b1ca9b7c/iso-7619-1997>

INTERNATIONAL

ISO



Reference number  
ISO 7619:1997(E)

## Foreword

ISO (the International Organization for Standardization) is a worldwide federation of national standards bodies (ISO member bodies). The work of preparing International Standards is normally carried out through ISO technical committees. Each member body interested in a subject for which a technical committee has been established has the right to be represented on that committee. International organizations, governmental and non-governmental, in liaison with ISO, also take part in the work. ISO collaborates closely with the International Electrotechnical Commission (IEC) on all matters of electrotechnical standardization.

Draft International Standards adopted by the technical committees are circulated to the member bodies for voting. Publication as an International Standard requires approval by at least 75 % of the member bodies casting a vote.

International Standard ISO 7619 was prepared by Technical Committee ISO/TC 45, *Rubber and rubber products*, (Sub-Committee SC 2, *Physical and degradation tests*).

This second edition cancels and replaces the first edition (ISO 7619:1986). The main modifications with respect to the first edition are the following.

- a new note (note 1) has been added to clause 1, this note replacing the second paragraph of clause 3;
- in 4.1.4 b), the equation has been modified;
- in 4.2.3 and 4.2.4, the minimum hardness for calibration of the durometer has been changed from 25 IRHD to 30 IRHD;
- a footnote relating to 8.1 has been added;
- a footnote relating to 8.2.2 has been added;
- a new clause (clause 9) on the precision of the test method has been added between the clauses on “Calibration” and “Test report” (now clause 10);
- a new annex (annex A) on guidance for using precision results has been added.

Annex A of this International Standard is for information only.

© ISO 1997

All rights reserved. Unless otherwise specified, no part of this publication may be reproduced or utilized in any form or by any means, electronic or mechanical, including photocopying and microfilm, without permission in writing from the publisher.

International Organization for Standardization  
Case postale 56 • CH-1211 Genève 20 • Switzerland  
Internet: central@iso.ch  
X.400: c=ch; a=400net; p=iso; o=isocs; s=central

Printed in Switzerland

# Rubber — Determination of indentation hardness by means of pocket hardness meters

**WARNING** — Persons using this International Standard should be familiar with normal laboratory practice. This standard does not purport to address all of the safety problems, if any, associated with its use. It is the responsibility of the user to establish appropriate safety and health practices and to ensure compliance with any national regulatory conditions.

## 1 Scope

**1.1** This International Standard specifies a method for the determination of the indentation hardness of rubber by means of pocket hardness meters of two types:

- a) the Shore-type durometer;
- b) a meter calibrated in IRHD;

Two types of Shore-type durometer are described; durometer type A is used for rubbers in the normal hardness range and type D for rubbers in the high hardness range.

**1.2** The use of pocket meters is primarily intended for control purposes and is not recommended for specification purposes. For such purposes, the methods given in ISO 48 should be used. It is possible to increase the precision by fixing the pocket hardness tester on a support.

**1.3** A similar method for measuring the hardness of plastics is given in ISO 868:1985, *Plastics and ebonite — Determination of indentation hardness by means of a durometer (Shore hardness)*.

**NOTE 1** The hardness of rubber, as measured by the Shore A durometer or the IRHD meter, is not a simple fundamental property but is a complex response to an applied indentation. The measurement will depend upon the following factors:

- a) the elastic modulus of the rubber;
- b) the viscoelastic properties of the rubber;
- c) the thickness of the test piece;
- d) the geometry of the indenter;
- e) the pressure exerted;
- f) the rate of increase of pressure;
- g) the interval at which the hardness is recorded.

Because of these factors, results using a Shore A durometer should not be related directly to IRHD values, although correlations have been established for some individual rubbers or compounds.

## 2 Normative references

The following standards contain provisions which, through reference in this text, constitute provisions of this International Standard. At the time of publication, the editions indicated were valid. All standards are subject to revision, and parties to agreements based on this International Standard are encouraged to investigate the possibility of applying the most recent editions of the standards indicated below. Members of IEC and ISO maintain registers of currently valid International Standards.

ISO 48:1994, *Rubber, vulcanized or thermoplastic — Determination of hardness (hardness between 10 IRHD and 100 IRHD)*.

ISO 471:1995, *Rubber — Times, temperatures and humidities for conditioning and testing*.

## 3 Principle

The measured property is the penetration of a specified indenter forced into the material under specified conditions.

## 4 Apparatus

### 4.1 Shore-type durometers: Types A and D

The durometers consist of the components described in 4.1.1 to 4.1.4.

**4.1.1 Pressure foot**, with a central hole of diameter between 2,5 mm and 3,2 mm, centred at least 6 mm from any edge of the foot.

**4.1.2 Indentor**, formed from a hardened steel rod of 1,25 mm ± 0,15 mm diameter to the shape and dimension shown in figure 1, for type A durometers, and figure 2 for type D durometers.

**4.1.3 Indicating device**, allowing the extent of protrusion of the point of the indenter beyond the face of the pressure foot to be read off; the device shall be calibrated directly in terms of units ranging from 0, for the maximum protrusion of 2,50 mm ± 0,04 mm, to 100 for nil protrusion obtained by placing the pressure foot and indenter in firm contact with a flat piece of glass.

**4.1.4 Calibrated spring**, to apply force to the indenter in accordance with one of the following equations:

$$a) \quad F = 550 + 75 H_A$$

where

$F$  is the applied force, in millinewtons;

$H_A$  is the hardness reading on the type A durometer.

$$b) \quad F = 445 H_D$$

where

$F$  is the applied force, in millinewtons;

$H_D$  is the hardness reading on the type D durometer.

Dimensions in millimetres

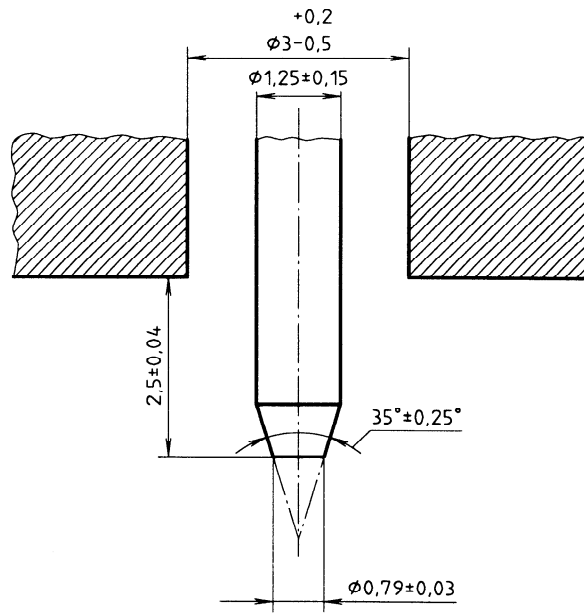
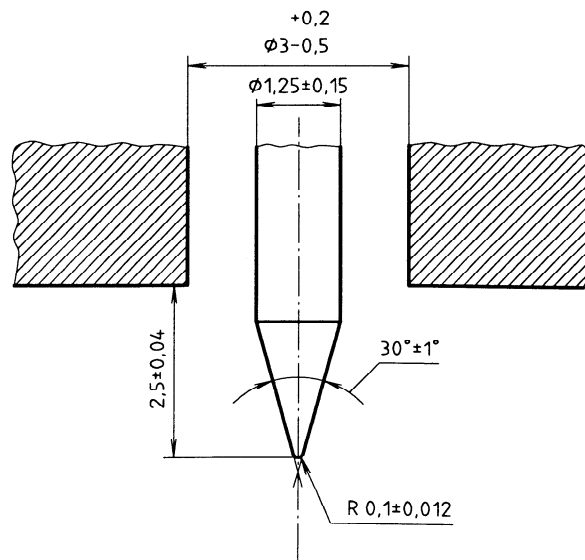

**Figure 1 — Indentor for type A durometer**  
(standards.iteh.ai)

ISO 7619:1997

<https://standards.iteh.ai/catalog/standards/sist/6f6d37bd-de1c-45cc-a7ae-9ec7b1ca9b7c/iso-7619-1997>

Dimensions in millimetres



**Figure 2 — Indentor for type D durometer**

## 4.2 The IRHD pocket hardness meter

The meter calibrated in IRHD consists of the components described in en 4.2.1 to 4.2.4.

**4.2.1 Pressure foot**, 20 mm  $\pm$  2,5 mm square with a central hole of diameter between 2,0 mm and 3,0 mm.

**4.2.2 Indentor**, the end being hemispherical, of diameter 1,55 mm to 1,60 mm.

**4.2.3 Indicating device**, allowing the extent of protrusion of the indentor beyond the face of the pressure foot to be read; the device shall be calibrated directly in terms of IRHD from 30° for maximum protrusion of 1,65 mm to 100° for nil protrusion obtained by placing the pressure foot and indentor in firm contact with a flat piece of glass.

**4.2.4 Calibrated spring**, for applying a substantially constant force to the indentor of 2,65 N  $\pm$  0,15 N over the 30 IRHD to 100 IRHD range.

## 5 Test piece

**5.1** For the determination of hardness by pocket hardness meters, the thickness of the piece shall be at least 6 mm.

For sheets thinner than 6 mm, a test piece may be composed of not more than three layers, none of which shall be thinner than 2 mm, to obtain the necessary thickness, but determinations made on such test pieces may not agree with those made on single-thickness pieces.

For comparison purposes, the test pieces shall be similar.

**5.2** The other dimensions of the test piece shall be sufficient to permit measurements at least 12 mm away from any edge. The surface of the test piece shall be flat over the area in contact with the pressure foot.

Satisfactory hardness determinations cannot be made on rounded, uneven or rough surfaces using pocket meters. However, their use in certain specialized applications is recognized, e.g. for determination of hardness of rubber-covered rolls. In such applications, the limitations of their use shall be clearly identified.

## 6 Conditioning

Where practical, test pieces shall be conditioned immediately before testing for a minimum period of 1 h at the standard temperature in accordance with ISO 471. The same temperature shall be used throughout any one test or series of tests intended to be comparable.

## 7 Procedure

**7.1** Place the test piece on a hard, rigid surface. Hold the hardness meter in position with the centre of the indentor at least 12 mm from the edges of the test piece. Apply the pressure foot to the test piece as rapidly as possible, without shock, keeping the foot parallel to the surface of the test piece and ensuring that the indentor is normal to the rubber surface.

Apply just sufficient force to obtain firm contact between the pressure foot and the test piece. Unless otherwise specified, take the reading within 1 s after the pressure foot is in firm contact with the test piece. When a reading after another time-interval is specified, hold the pressure foot in contact with the test piece without change in position and pressure and take the reading after the specified time.

**7.2** Make five measurements of hardness at different positions on the test piece at least 6 mm apart and determine the mean value.

**7.3** When using Shore-type durometers, it is recommended that measurements be made with the type D instrument when values above 90 are obtained with the type A durometer, and that measurements be made with the type A instrument when values less than 20 are obtained with type D durometers. Values below 10 on the type A apparatus are inexact and should not be reported.

NOTE 2 Better precision may be obtained by using either a stand or a weight centred on the axis of the indenter, or both, to apply the pressure foot to the test piece. For Shore-type durometers, masses of 1 kg and 5 kg are recommended for type A and type D respectively.

## 8 Calibration

### 8.1 Shore-type durometers

The spring of the durometer shall be calibrated by supporting the durometer in a vertical position and resting the point of the indenter on a small spacer at the centre of one pan of a balance, as shown in figure 3, in order to prevent interference between the pressure foot and the pan. The spacer has a small cylindrical stem of height approximately 2,5 mm and diameter approximately 1,25 mm and is slightly cupped on top to accommodate the indenter point. The weight of the spacer shall be balanced by a weight on the opposite pan of the balance. Weights shall be added to the opposite pan to balance the force on the indenter at various scale readings. The measured force shall be equal to the force calculated by the relevant equation given in 4.1.4. For type A instruments, the force shall be within  $\pm 80$  mN of the calculated value and for type D instruments within  $\pm 440$  mN.

Alternatively, electronic balances or instruments specifically designed for calibration of durometers may be used.<sup>1)</sup> Balances or instruments used for calibration should be capable of measuring or applying force on the point of the indenter within 8,0 mN for the type A durometer and within 44,0 mN for the type D durometer.

[ISO 7619:1997](https://standards.iteh.ai/catalog/standards/sist/6f6d37bd-de1c-45cc-a7ae-9ec7b1ca9b7c/iso-7619-1997)

### 8.2 IRHD pocket hardness meter

<https://standards.iteh.ai/catalog/standards/sist/6f6d37bd-de1c-45cc-a7ae-9ec7b1ca9b7c/iso-7619-1997>

#### 8.2.1 General

The instrument shall be calibrated and adjusted frequently, preferably against a range of standard rubber blocks that have been previously calibrated against a dead-load gauge by the method specified in ISO 48. Calibration of the instrument by mechanical means is recommended only where no suitable standard rubber test pieces are available. In such cases the manufacturer's instructions should be followed.

1) Instruments for the calibration of durometers are available from  
Shore/Wilson Hardness Testing Products, Instron Corporation, 100 Royal Street, M/S Shore, Canton, MA  
02021-1089, USA;  
and  
Zwick GmbH & Co., Postfach 4350, D-7900 Ulm, Germany.

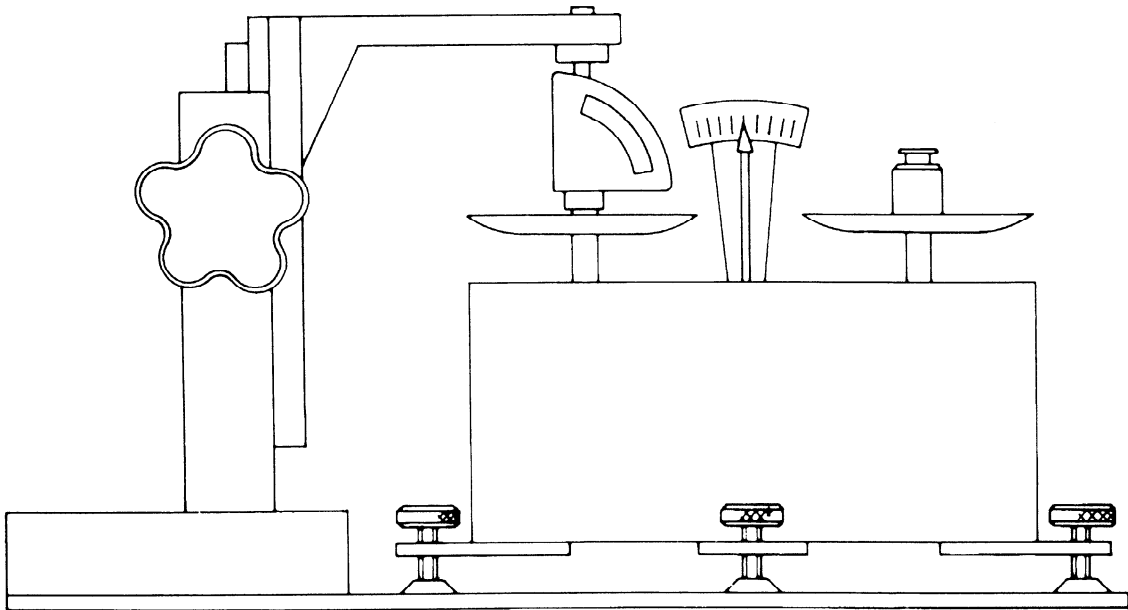

Figure 3 — Apparatus for calibration of durometer spring

### 8.2.2 Calibration using standard rubber blocks<sup>2)</sup>

Press the instrument against a flat piece of glass and adjust the reading on the scale to give 100 IRHD. Using a set of standard rubber blocks covering the range approximately 30 IRHD to 90 IRHD, calibrate the instrument. All adjustments shall be made according to the manufacturer's instructions. The set of standard rubber blocks shall consist of at least six test pieces kept lightly dusted with talc in a suitable covered container away from light, heat, oil and grease. The standard rubber blocks shall themselves be calibrated against the dead-load gauge by the method specified in ISO 48 at intervals not exceeding 6 months.

It is recommended that instruments in regular use be recalibrated at least each week against the standard rubber blocks.

## 9 Precision

### 9.1 General

The precision calculations to express repeatability and reproducibility were performed according to ISO/TR 9272:1986, *Rubber and rubber products — Determination of precision for test method standards*. Consult this for precision concepts and nomenclature. Annex A gives guidance on the use of repeatability and reproducibility.

### 9.2 Precision details

**9.2.1** An interlaboratory test programme (ITP) was organized and conducted by Statens Provningsanstalt (Sweden) in late 1985. Cured test pieces of four rubber compounds (materials) were prepared in one laboratory and sent to all participants. The nominal hardness values were 30, 45, 65 and 85. Thirty-two laboratories participated for measurement of the Shore meter hardness. On each of 2 days, 1 week apart, five determinations (measurements) of hardness were made on each compound. The median of the five values was used as a "test result" for the precision analysis.

2) Standard rubber blocks are available from Rapra Technology Ltd., Shawbury, Shrewsbury, Shropshire SY4 4NR, UK.



**9.2.2** Only four laboratories participated in tests with the IRHD-type pocket meter. This small database for precision yields only a rough approximation of repeatability and reproducibility, and is not included here.

**9.2.3** The precision assessment is a type 1 (cured prepared test pieces circulated) and the time for repeatability and reproducibility is on a scale of days.

### 9.3 Precision results

The precision results for the Shore hardness meter are given in table 1. The symbols used in this table are defined as follows:

$r$  = repeatability, in measurement units,

$(r)$  = repeatability, in percent (relative),

$R$  = reproducibility, in measurement units,

$(R)$  = reproducibility, in percent (relative).

**Table 1 — Type 1 precision for a Shore hardness meter**

| Material      | Average value | Within-laboratory repeatability |       | Interlaboratory reproducibility |       |
|---------------|---------------|---------------------------------|-------|---------------------------------|-------|
|               |               | $r$                             | $(r)$ | $R$                             | $(R)$ |
| A             | 32,7          | 2,67                            | 8,15  | 6,41                            | 19,6  |
| B             | 47,2          | 1,65                            | 3,49  | 4,80                            | 10,2  |
| C             | 65,6          | 1,53                            | 2,34  | 2,83                            | 4,31  |
| D             | 80,2          | 1,64                            | 2,04  | 5,19                            | 6,46  |
| Pooled values | 56,2          | 1,93                            | 3,42  | 5,03                            | 8,94  |

[ISO 7619:1997](https://standards.iteh.ai/catalog/standards/sist/6f6d37bd-de1c-45cc-a7ae-9ec7b1ca9b7c/iso-7619-1997)

<https://standards.iteh.ai/catalog/standards/sist/6f6d37bd-de1c-45cc-a7ae-9ec7b1ca9b7c/iso-7619-1997>

## 10 Test report

The test report shall include the following information:

- a) a reference to this International Standard;
- b) sample details:
  - 1) a full description of the sample and its origin,
  - 2) compound details and curing conditions, if known,
  - 3) a description of the test piece, including its thickness and, in the case of a composite test piece, the number of layers;
- c) test details:
  - 1) the temperature of test, and the relative humidity when the hardness of the material is dependent on the humidity,
  - 2) the type of instrument used,
  - 3) the time which elapsed between the preparation of the test piece and the measurement of hardness,
  - 4) any deviation from the standard procedure,
  - 5) details of procedure not specified in this International Standard, and any incidents likely to have had an influence on the results;