



SLOVENSKI STANDARD

SIST EN 10264-3:2003

01-april-2003

>Y_`YbUÿjWU]b`ÿ] b]`]nXY_]!`>Y_`YbUÿjWU]nUj fj]!` "XY.`C_fc[`U]b`cV]_cj UbU
bY Y[]fUbU`Y_`YbUÿjWU]nUj Y_]Y`cVfYa Yb]h] Y

Steel wire and wire products - Steel wire for ropes - Part 3: Round and shaped non alloyed steel wire for high duty applications

Stahldraht und Drahterzeugnisse - Stahldraht für Seile - Teil 3: Runder und profilierter Draht aus unlegiertem Stahl für hohe Beanspruchungen

Fils et produits tréfilés en acier - Fils pour câbles - Partie 3: Fils ronds et profilés, en acier non allié, pour fortes sollicitations

[SIST EN 10264-3:2003](https://standards.iteh.ai/catalog/standards/sist/bdd46b7f-26b0-4d04-a1ac-22876d001e6d/sist-en-10264-3-2003)

[https://standards.iteh.ai/catalog/standards/sist/bdd46b7f-26b0-4d04-a1ac-](https://standards.iteh.ai/catalog/standards/sist/bdd46b7f-26b0-4d04-a1ac-22876d001e6d/sist-en-10264-3-2003)

[22876d001e6d/sist-en-10264-3-2003](https://standards.iteh.ai/catalog/standards/sist/bdd46b7f-26b0-4d04-a1ac-22876d001e6d/sist-en-10264-3-2003)

Ta slovenski standard je istoveten z: EN 10264-3:2002

ICS:

77.140.45	Nelegirana jekla	Non-alloyed steels
77.140.65	Jeklene žice, jeklene vrvi in verige	Steel wire, wire ropes and link chains

SIST EN 10264-3:2003

en

iTeh STANDARD PREVIEW
(standards.iteh.ai)

SIST EN 10264-3:2003

<https://standards.iteh.ai/catalog/standards/sist/bdd46b7f-26b0-4d04-a1ac-22876d001e6d/sist-en-10264-3-2003>

EUROPEAN STANDARD

EN 10264-3

NORME EUROPÉENNE

EUROPÄISCHE NORM

November 2002

ICS 77.140.65

English version

Steel wire and wire products - Steel wire for ropes - Part 3: Round and shaped non alloyed steel wire for high duty applications

Fils et produits tréfilés en acier - Fils pour câbles - Partie 3:
Fils ronds et profilés, en acier non allié, pour fortes
sollicitations

Stahldraht und Drahterzeugnisse - Stahldraht für Seile -
Teil 3: Runder und profilierter Draht aus unlegiertem Stahl
für hohe Beanspruchungen

This European Standard was approved by CEN on 9 October 2002.

CEN members are bound to comply with the CEN/CENELEC Internal Regulations which stipulate the conditions for giving this European Standard the status of a national standard without any alteration. Up-to-date lists and bibliographical references concerning such national standards may be obtained on application to the Management Centre or to any CEN member.

This European Standard exists in three official versions (English, French, German). A version in any other language made by translation under the responsibility of a CEN member into its own language and notified to the Management Centre has the same status as the official versions.

CEN members are the national standards bodies of Austria, Belgium, Czech Republic, Denmark, Finland, France, Germany, Greece, Iceland, Ireland, Italy, Luxembourg, Malta, Netherlands, Norway, Portugal, Spain, Sweden, Switzerland and United Kingdom.

<https://standards.iteh.ai/catalog/standards/sist/bdd46b7f-26b0-4d04-a1ac-22876d001e6d/sist-en-10264-3-2003>



EUROPEAN COMMITTEE FOR STANDARDIZATION
COMITÉ EUROPÉEN DE NORMALISATION
EUROPÄISCHES KOMITEE FÜR NORMUNG

Management Centre: rue de Stassart, 36 B-1050 Brussels

Contents

	page
Foreword.....	3
1 Scope	4
2 Normative references	4
3 Designation of the product	4
4 General conditions of manufacture	5
5 Characteristics of the wire	5
5.1 Tensile strength grades	5
5.2 Profiles	6
5.2.1 Definition of shaped wire	6
5.2.2 Equivalent diameter	8
5.3 Minimum requirements for wire characteristics.....	8
5.3.1 Dimension – measured values	8
5.3.2 Reverse bend test	9
5.3.3 Torsion test.....	13
5.3.4 Zinc and Zn95/Al5 coatings	15
6 Test methods.....	16
6.1 General.....	16
6.2 Reverse bend test	16

[SIST EN 10264-3:2003](https://standards.iteh.ai/catalog/standards/sist/bdd46b7f-26b0-4d04-a1ac-22876d001e6d/sist-en-10264-3-2003)

<https://standards.iteh.ai/catalog/standards/sist/bdd46b7f-26b0-4d04-a1ac-22876d001e6d/sist-en-10264-3-2003>

Foreword

This document EN 10264-3:2002 has been prepared by Technical Committee ECISS/TC 30 "Steel wires", the secretariat of which is held by BSI.

This European Standard shall be given the status of a national standard, either by publication of an identical text or by endorsement, at the latest by May 2003, and conflicting national standards shall be withdrawn at the latest by May 2003.

This European Standard for wire for ropes is made up of the following parts:

Part 1: *General requirements*

Part 2: *Cold drawn non alloyed steel wire for ropes for general applications*

Part 3: *Round and shaped non alloyed steel wire for high duty applications*

Part 4: *Stainless steel wire*

According to the CEN/CENELEC Internal Regulations, the national standards organizations of the following countries are bound to implement this European Standard: Austria, Belgium, Czech Republic, Denmark, Finland, France, Germany, Greece, Iceland, Ireland, Italy, Luxembourg, Malta, Netherlands, Norway, Portugal, Spain, Sweden, Switzerland and the United Kingdom.

ITEH STANDARD PREVIEW
(standards.iteh.ai)

SIST EN 10264-3:2003

<https://standards.iteh.ai/catalog/standards/sist/bdd46b7f-26b0-4d04-a1ac-22876d001e6d/sist-en-10264-3-2003>

EN 10264-3:2002 (E)**1 Scope**

This part of this European Standard specifies round and shaped non alloyed steel wire for use in the manufacture of ropes for mine hoisting, man-riding haulage, cableways for the transportation of passengers and other high duty applications.

This part of this European Standard refers to round wires and three types of shaped wire: full lock (Z), half lock (H) and trapezoidal (T).

In addition to the requirements of this part of this European Standard, the requirements of EN 10264-1 also apply.

It does not apply to steel wire taken from manufactured ropes.

This part of this European Standard specifies the following for cold drawn non alloyed steel wire for ropes for high duty applications:

- dimensional tolerances;
- mechanical characteristics;
- requirements relating to the chemical composition of the steel wire;
- conditions to be satisfied by any coating.

2 Normative references

This European Standard incorporates by dated or undated reference, provisions from other publications. These normative references are cited at the appropriate places in the text, and the publications are listed hereafter. For dated references, subsequent amendments to or revisions of any of these publications apply to this European Standard only when incorporated in it by amendment or revision. For undated references the latest edition of the publication referred to applies (including amendments).

EN 10016-1, *Non-alloy steel rod for drawing and/or cold rolling – Part 1: General requirements.*

EN 10016-2, *Non-alloy steel rod for drawing and/or cold rolling – Part 2: Specific requirements for general purposes rod.*

EN 10016-4, *Non-alloy steel rod for drawing and/or cold rolling – Part 4: Specific requirements for rod for special applications.*

EN 10218-1, *Steel wire and wire products – General – Part 1: Test methods.*

EN 10244-2, *Steel wire and wire products – Non ferrous metallic coatings on steel wire – Part 2: Zinc or zinc alloy coatings.*

EN 10264-1, *Steel wire and wire products – Steel wire for ropes – Part 1: General requirements.*

3 Designation of the product

The designation of wire for ropes manufactured in accordance with this European Standard shall be based on the nominal dimension, surface appearance and tensile strength.

The indicator of dimension for round wire is the nominal diameter; for shaped wire it is the value of the height (h), followed by a letter specifying the profile. In the case of H profiles, this indicator shall be followed by the value of the narrowing.

The surface appearance is indicated as defined in EN 10264-1 with U for uncoated or bright wire, with a letter indicating the class of coating (A, B, ...) and in the case of zinc alloy coatings, indicating in brackets (Zn/Al).

EXAMPLE 1: 2,0 mm wire for rope with thick zinc layer, class A, tensile strength grade 1570 MPa, in accordance with EN 10264-3.

Designation: wire for rope EN 10264-3 – 2,0 - A - 1570.

EXAMPLE 2: Wire for rope, trapezoidal profile, $h = 3,5$ mm, class B zinc coated, tensile strength grade 1770 MPa, in accordance with EN 10264-3.

Designation: wire for rope EN 10264-3 - T3,5 - B - 1770

EXAMPLE 3: H shaped wire for rope $h = 3,0$ mm, $w = 1,8$ mm, coated with class A zinc alloy, tensile strength grade 1370 MPa, in accordance with EN 10264-3.

Designation: wire for rope EN 10264-3 - H – 3,0 × 1,8 - A (Zn/Al) - 1370

4 General conditions of manufacture

The drawn wire shall be manufactured from rod in accordance with EN 10016-1 and EN 10016-2 for ropes for static applications, and in accordance with EN 10016-1 and EN 10016-4 for ropes for dynamic applications.

The drawn wire shall show no surface defects or internal defects prejudicial to its use.

When specified, the drawn wire shall be supplied with a coating applied by a hot dipping or electrolytic method. The coatings commonly used are zinc or Zn95/Al5.

Unless otherwise specified, the zinc used for coating shall have a purity of 99,9 %. Other zinc alloys may be agreed at the time of enquiry and order.

NOTE If required by the purchaser, the quality of the zinc or zinc alloy used for the coating material (zinc or zinc alloy) should be certified by the manufacturer. Because of the reaction between the base material and coating material, which is inherent to the process, the composition of the coating on the wire is different to that used in the coating bath.

5 Characteristics of the wire

5.1 Tensile strength grades

The tensile strength grades are defined in Table 1.

NOTE The nominal values are the minimum tensile strength limits. The upper limits (maximum) are equal to these minimum values increased with the tolerances specified in EN 10264-1 Table 1.

Table 1 — Tensile strength grade

Quality of wire		Nominal tensile strength grade							
		MPa ^a							
Round	Bright or coated Class B	-	-	-	1570	-	1770	1960	2160
	Zinc or Zn95/Al5 - Class A	-	-	-	1570	-	1770	-	-
Shaped	Bright or coated Class B or class D ^b	-	1370	-	1570	-	1770	-	-
		1270	1370	1470	1570	1670	1770	-	-
	Zinc or Zn95/Al5 - Class A	-	1370	-	1570	-	-	-	-

NOTE Subject to agreement between the manufacturer and the purchaser, other tensile strength grades can be used.
^a 1 MPa = 1 N/mm².
^b Mass of coatings for static and dynamic applications are specified in Table 10.

5.2 Profiles

5.2.1 Definition of shaped wire

For shaped wire, the characteristic sections of the wire are shown in Figure 1 for full lock Z, half lock H and trapezoidal T wires.

The nominal dimensions and tolerances shall be agreed between the supplier and the purchaser at the time of ordering. The conventional characteristic values are as follows:

h: height: difference between the radii of the 2 concentric boundary circles.

b: width: maximum width of upper part perpendicular to a radial line passing through the centre of the width (as shown in Figure 1).

w: minimum narrowing: is the smallest width of the profile.

e: distance taken diagonally across the transverse section of the profile (essentially trapezoidal or T profile).

The designation of a full lock wire is established using the letter Z and the height (*h*), that of a half lock wire by H followed by the height (*h*) and the minimum narrowing (*w*) (*h* x *w*) and that of a trapezoidal wire by the letter T followed by the height (*h*).

Table 2 gives the design criteria for the shaped wire shown in Figure 1. These are the relation between the height of the shaped wires and the other major characteristic dimensions.

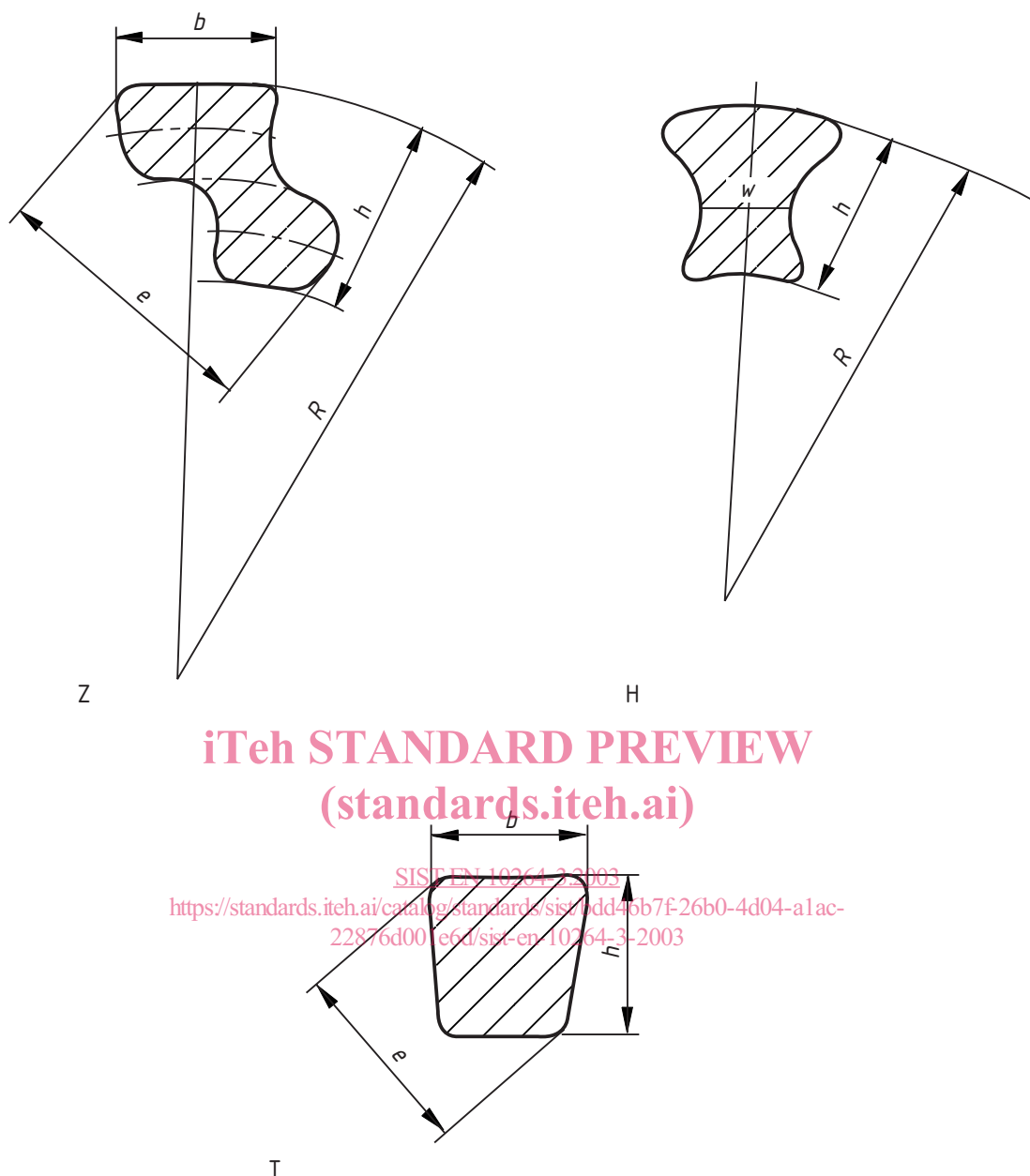

Figure 1 — Shaped wire sections

Table 2 — Design criteria for shaped wire

Ratio	Z profile	H profile	Trapezoidal profile T
$h : b$	0,9 to 1,3	-	1,0 to 1,3
$h : e$	0,55 to 0,75	-	0,75 to 0,90
$h : w$	-	1,1 to 2,3	