



Designation: D 5664 – 02

Standard Test Method for Evaluating the Effects of Fire-Retardant Treatments and Elevated Temperatures on Strength Properties of Fire- Retardant Treated Lumber¹

This standard is issued under the fixed designation D 5664; the number immediately following the designation indicates the year of original adoption or, in the case of revision, the year of last revision. A number in parentheses indicates the year of last reapproval. A superscript epsilon (ϵ) indicates an editorial change since the last revision or reapproval.

1. Scope

1.1 This test method covers procedures for obtaining data to assess the initial adjustments to allowable design stresses for lumber treated with candidate commercial fire-retardant (FR) formulations and further procedures for obtaining data to assess the effect of extended exposure to elevated temperature of $66 \pm 2^\circ\text{C}$ ($150 \pm 4^\circ\text{F}$).

1.2 *This standard does not purport to address all of the safety concerns, if any, associated with its use. It is the responsibility of the user of this standard to establish appropriate safety and health practices and determine the applicability of regulatory limitations prior to use.*

2. Referenced Documents

2.1 ASTM Standards:

- D 9 Terminology Relating to Wood²
- D 143 Methods of Testing Small Clear Specimens of Wood²
- D 1165 Nomenclature of Domestic Hardwoods and Softwoods²
- D 3500 Test Methods for Structural Panels in Tension²
- D 4761 Test Method for Mechanical Properties of Lumber and Wood-Base Structural Material²
- D 5516 Test Method for Evaluating the Flexural Properties of Fire-Retardant Treated Softwood Plywood Exposed to Elevated Temperatures²
- E 84 Test Method for Surface Burning Characteristics of Building Materials³
- E 176 Terminology of Fire Standards³

2.2 Other Standards:

- AWPA C20 Lumber—Fire Retardant Treatment by Pressure Processes⁴

¹ This test method is under the jurisdiction of ASTM Committee D07 on Wood and is the direct responsibility of Subcommittee D07.07 on Fire Performance of Wood.

Current edition approved Sept. 10, 2002. Published November 2002. Originally published as D 5664–95. Last previous edition D 5664–01a.

² *Annual Book of ASTM Standards*, Vol 04.10.

³ *Annual Book of ASTM Standards*, Vol 04.07.

⁴ Available from American Wood-Preservers Assoc., P.O. Box 5690, Granbury, TX 76049–0690.

- NFPA 703 Standard for Fire Retardant Impregnated Wood and Fire Retardant Coatings for Building Materials⁵
- U.S. Product Standard PS 20 American Softwood Lumber Standard⁶

3. Terminology

3.1 *Definitions*—Definitions used in this test method are in accordance with Terminologies D 9 and E 176 and Nomenclature D 1165.

4. Summary of Test Method

4.1 The general objectives of this test method are to develop data to adjust allowable design stresses of FR-treated lumber for the initial effects for the tested FR-formulation(s) and to develop data on in-service thermal stability after extended exposure to environmental conditions up to $66 \pm 2^\circ\text{C}$ ($150 \pm 4^\circ\text{F}$) and $\geq 50\%$ relative humidity.

4.2 *Procedure 1*—This procedure uses small clear specimens cut from end-matched nominal 2 by 4 (38 by 89-mm) dimension lumber (see Fig. 1) to compare the initial effects of fire-retardant treatments to untreated controls for bending, tension parallel, compression parallel, and horizontal shear properties.

4.3 *Procedure 2*—This procedure uses small clear specimens cut from end matched nominal 2 by 4 (38 by 89-mm) dimension lumber. This second set of specimens is used to assess the differential trends between end-matched fire-retardant treated and untreated specimens on bending and tension parallel properties over the course of a prolonged exposure to elevated temperature.

4.4 *Procedure 3*—The optional third procedure uses full-sized nominal 2 by 4 (38 by 89-mm) dimension lumber to modify the small clear specimen results from 4.2 and 4.3 for size effects.

⁵ Available from National Fire Protection Association, P.O. Box 9191, Quincy, MA 02269-9101.

⁶ Available from The American Lumber Standard Committee, P.O. Box 210, Germantown, MD 20875-0210.

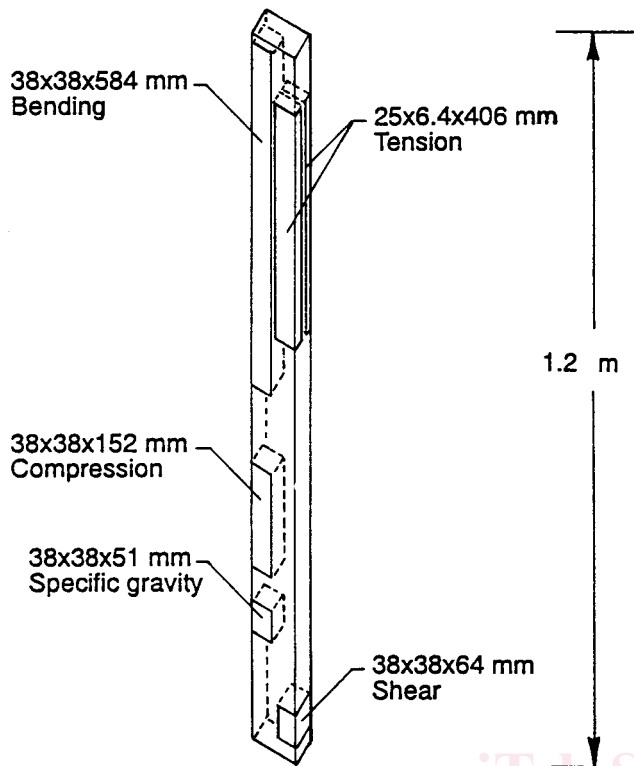

FIG. 1 Hypothetical Cutting Patterns to Obtain One Bending, Two Tension Parallel, One Compression Parallel, One Block Shear, and One Specific Gravity Block from Each 1.2-m (4-ft) Lumber Specimen

5. Significance and Use

5.1 The mechanical properties evaluated by this test method provide the following:

5.1.1 Data for use in developing modification factors for the allowable design properties of fire-retardant treated lumber when used at or near room temperatures (see 6.3).

5.1.2 Data for use in developing modification factors for allowable design properties of fire-retardant treated lumber when exposed to elevated temperatures and humidity (see 6.4).

5.1.3 Data (optional) for use in modifying these factors for size effects when fire-retardant treated lumber is used at or near room temperature and when exposed to elevated temperatures and humidity (see 6.5).

5.2 Data from the first two procedures in this test method of evaluation are indicative only for that species.

NOTE 1—The results of the three listed species (Southern pine, Douglas fir, and either white spruce or a Spruce/Fir mixture) may be used together to make inference on untested wood species because the three tested species represent the full spectrum of expected treatability.

5.3 Data from the optional third part of this three-part method of evaluation are indicative for all species because it is primarily used to assess size effects.

6. Procedures

6.1 Treatment:

6.1.1 Pressure treat those pieces designated for treatment with the fire-retardant formulation being evaluated. The gage retention level of each charge shall not be less than the

midpoint of the retention range as specified for the species by the agency certifying the flame spread index of the treated lumber. The retention range specified by the certifying agency shall provide a flame-spread index of 25 or less when tested in accordance with Test Method E 84 for 10 min, show no evidence of significant progression combustion when the test is continued for an additional 20-min period and not allow progression of the flame front beyond a distance of 3.2 m (10.5 ft) beyond the centerline of the burners anytime during the 30-min extended test.

6.1.1.1 The provisions of 6.1.1 are not intended to prevent use of this test standard when the fire-retardant treatments being certified are for applications other than those requiring conformance to AWPA Standard C-20, NFPA Standard 703, or similar building code requirements for “fire-retardant-treated wood” that require the Test Method E 84 test extended to 30 min. When alternative performance criteria for the treatment are being certified, the test report on specimens of that treatment shall state clearly the alternative performance criteria and that the treatment retention was limited to that required for the alternative performance criteria.

6.1.2 Weigh all treated pieces before and immediately after treatment to determine the chemical retention based on the solution retained and the concentration of chemicals in the solution. Complete a treating report for each charge of material to document the treating cycle, times, pressures, gage retention, and piece retentions.

6.2 Post-treatment Drying:

6.2.1 After pressure treatment, kiln dry the treated pieces to a maximum moisture content of 19 % following the standard redrying procedures established for the treatment and species by the manufacturer. Redry the treated pieces at the manufacturer’s maximum specified dry bulb temperature with a minus 2°C (4°F) tolerance for 21 h of the first 24-h period. For the remainder of the drying period, the tolerance shall be minus 3°C (5°F). There is no upper limit on the redrying temperature. Sticker all test pieces to obtain proper air flow across both surfaces and to provide even drying.

NOTE 2—Research has shown that high kiln drying temperatures can adversely affect the structural properties of wood products. The American Wood-Preservers’ Association (AWPA) and National Fire Protection Association (NFPA) standards for fire retardant treated wood products limit kiln dry bulb temperatures. AWPA Standard C20 requires that the dry bulb temperature of the kiln not exceed 70°C (160°F) during any kiln drying of plywood treated with fire retardants. In the case of exterior fire-retardants that require curing at higher temperatures, curing after the moisture content is 19 % or less is permitted. However, such elevated curing temperatures must not exceed 99°C (210°F) and the total curing time must not exceed 48 h. In NFPA Standard 703, the dry bulb temperature must not exceed 70°C (160°F) until the average moisture content of the wood has dropped to 25 % or less.

NOTE 3—To establish the worst-case strength properties of treated lumber, the laboratory must redry the test material within a small negative tolerance of the maximum temperature used by the manufacturer. Therefore, there is no upper limit for the temperature used in the tests. If a manufacturer desires to establish conservative property values or provide a basis for evaluating production material that exceeds the limit, the test material can be redried at that temperature. A manufacturer then is allowed to determine the necessary production schedule for their treatment and equipment or conditions. Thus, a stepped schedule (for example, 10 h at 54°C (130°F), 10 h at 60°C (140°F); 10 h at 71°C (160°F), etc.) is allowed

by the standard, provided the maximum temperature tolerance requirement is met. These provisions provide for air-drying production material provided the redry conditions in the tests are within the tolerance of the maximum temperature specified by the manufacturer.

6.2.2 Monitor the moisture content of the test pieces during the drying cycle by individually weighing representative pieces. Keep a well-documented kiln charge report and kiln recorder chart showing dry and wet bulb temperatures during the redrying period.

6.3 Procedure 1—The first procedure presents a methodology using small clear wood specimens to assess the initial effect of fire-retardant treatment on median mechanical properties. The results may be used to adjust the allowable design stresses of lumber based on estimates of median reductions in bending, tension parallel, compression parallel, and horizontal shear properties using small clear specimens cut from larger end-matched dimension lumber specimens.

6.3.1 For each species/species grouping (Southern pine, Douglas fir, and either white spruce or a Spruce/Fir mixture), twenty five (25) 2.44-m (8-ft) long, high-grade nominal 2 by 4s (38 by 89 mm) shall be obtained and cut into 1.22-m (4-ft) halves. Each specimen shall be marked to identify it with its matched-sister(s) specimen(s). For each specimen, one 1.22-m (4-ft) half shall be randomly allotted to remain untreated and the other half assigned to be treated with the candidate fire-retardant treatment and each half shall be appropriately marked.

NOTE 4—A Spruce/Fir mixture can be obtained by obtaining Canadian Spruce-Pine-Fir and removing the Lodgepole pine and Jack pine, which can be visually segregated from the remaining spruces and firs of this specific species group. The Lodgepole pine and Jack pine have numerous longitudinal resin canals that are generally quite evenly distributed in the outer portion of every growth ring. In the four spruces (Black, Engelmann, Red, and White), the longitudinal resin canals are generally sparse. In the two firs (Alpine and Balsam), the longitudinal resin canals are normally absent.

NOTE 5—High Grade is a relative term, but some latitude is required because it is a common industry practice to group grades for some species/species groupings into “and better” categories. If available, Select Structural often is desirable because it provides an adequate yield of small clear specimens. It should also be noted that initial use of ≥ 30 specimens will usually ensure 25 acceptable specimens when using lower grades which have lower yields.

6.3.2 After treating and redrying are completed, each treated and untreated nominal 2 by 4 (38 by 89-mm) piece shall be cut into small clear specimens as shown in Fig. 1. Care shall be taken to avoid cutting specimens containing strength-reducing characteristics such as knots, cross-grain, or slope-of-grain in excess of 1 in 12. When cutting small test specimens, an original wide surface shall remain unmachined and each specimen shall later be tested so that this surface is exposed to the greater stress during that particular mechanical test. Each end-matched treated and untreated specimen shall be tested with the same relative surfaces in tension and compression. Tension parallel specimens shall be machined as shown in Fig. 2. Horizontal shear specimens shall be machined as shown in Fig. 3.

6.3.3 After cutting, all specimens (treated and untreated) shall be equilibrated to constant weight at $22 \pm 5^\circ\text{C}$ ($72 \pm 9^\circ\text{F}$) and $65 \pm 1\%$ relative humidity.

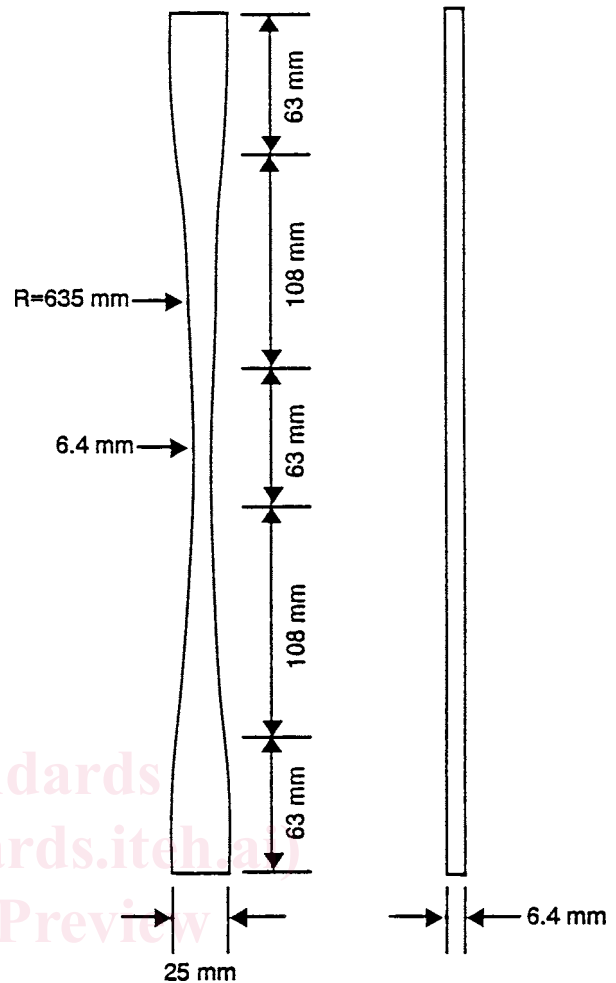

FIG. 2 Dimensions of the Modified Tension Parallel to Grain Specimen Using Test Methods D 3500

6.3.4 Appropriate treated and untreated specimens shall be alternately tested in bending, compression parallel, and horizontal shear using Methods D 143 and tension parallel using Test Methods D 3500, but with the exceptions listed in Table 1.

6.4 Procedure 2—For each species (Southern pine, Douglas fir and white spruce, four sets of 25 end-matched treated and untreated small clear bending and tension parallel specimens shall be cut from at least 25 nominal 2 by 4 (38 by 89 mm) 2.44-m (8-ft) long pieces. These specimens shall be used to assess the differential effects of exposure to elevated temperature between untreated and FR-treated clear wood specimens.

6.4.1 One set of 25 FR-treated and untreated specimens of each species shall be used as an unexposed control (that is, 0 days of exposure).

6.4.2 Three FR-treated and untreated groups of 25 specimens of each species shall be exposed in a controlled environment of $66 \pm 2^\circ\text{C}$ ($150 \pm 4^\circ\text{F}$) and $>50\%$ relative humidity.

6.4.3 One treated and one untreated group of 25 shall be withdrawn after 36 ± 3 , 72 ± 3 , and 108 ± 3 days.

6.4.4 Each group of specimens shall be equilibrated to constant weight at $22 \pm 5^\circ\text{C}$ ($72 \pm 9^\circ\text{F}$) and $65 \pm 1\%$ relative humidity then tested in bending in accordance with Methods D 143 and tension parallel in accordance with Test Methods D 3500, but with the exceptions listed in Table 1.