



Standard Test Method for Fire Testing of Mattresses¹

This standard is issued under the fixed designation E 1590; the number immediately following the designation indicates the year of original adoption or, in the case of revision, the year of last revision. A number in parentheses indicates the year of last approval. A superscript epsilon (ϵ) indicates an editorial change since the last revision or reapproval.

1. Scope

1.1 This is a fire-test-response standard.

1.2 This test method provides a means of determining the burning behavior of mattresses used in public occupancies by measuring specific fire test responses when the test specimen, a mattress or mattress with foundation, is subjected to a specified flaming ignition source under well ventilated conditions.

1.3 This is a test method for mattresses or mattresses with foundations.

1.4 Test data are obtained describing the burning behavior, following application of a specific ignition source, from ignition until all burning has ceased, a period of 1 h has elapsed, or flashover appears inevitable.

1.5 This test method does not provide information on the fire performance of mattresses under fire conditions other than those specified in this test method. In particular, this test method does not apply to smoldering ignition by cigarettes. See 5.12 for further information.

1.6 The rate of heat release of burning test specimen is measured by an oxygen consumption method. See 5.12.4 for further information.

1.7 Other measurements are the production of light-obscuring smoke and the concentrations of certain toxic gas species in the combustion gases. See 5.12.5 for further information.

1.8 The burning behavior is documented visually by photographic or video recordings.

1.9 Use the SI system of units in referee decisions; see Practice E 380. The units given in parentheses are for information only.

1.10 *This standard is used to measure and describe the response of materials, products, or assemblies to heat and flame under controlled conditions, but does not by itself incorporate all factors required for fire hazard or fire risk assessment of the materials, products or assemblies under actual fire conditions.*

1.11 *Fire testing of products and materials is inherently hazardous, and adequate safeguards for personnel and prop-*

erty shall be employed in conducting these tests. This test method may involve hazardous materials, operations, and equipment.

1.12 *This standard does not purport to address all of the safety concerns, if any, associated with its use. It is the responsibility of the user of this standard to establish appropriate safety and health practices and determine the applicability of regulatory limitations prior to use.*

2. Referenced Documents

2.1 ASTM Standards:

- D 123 Terminology Relating to Textiles²
- E 84 Test Method for Surface Burning Characteristics of Building Materials³
- E 176 Terminology of Fire Standards³
- E 380 Practice for Use of the International System of Units (SI) (the Modernized Metric System)⁴
- E 691 Practice for Conducting an Interlaboratory Study to Determine the Precision of a Test Method⁵
- E 800 Guide for Measurement of Gases Present or Generated During Fires³
- E 1354 Test Method for Heat and Visible Smoke Release Rates for Materials and Products Using an Oxygen Consumption Calorimeter³
- E 1474 Test Method for Determining the Heat Release Rate of Upholstered Furniture and Mattress Components or Composites Using a Bench Scale Oxygen Consumption Calorimeter³
- E 1537 Test Method for Fire Testing of Seating Upholstered Furniture³

2.2 ISO Standards:

- ISO 3261 Fire Tests—Vocabulary⁶
- ISO 4880 Burning Behaviour of Textiles and Textile Products—Vocabulary⁶
- ISO 9705 Fire Tests—Full Scale Room Test for Surface Products⁶

2.3 UL Standards:

² Annual Book of ASTM Standards, Vol 07.01.

³ Annual Book of ASTM Standards, Vol 04.07.

⁴ Discontinued 1997; Replaced by IEEE/ASTM SI-10.

⁵ Annual Book of ASTM Standards, Vol 14.02.

⁶ Available from International Standardization Organization, P.O. Box 56, CH-1211, Geneva 20, Switzerland.

¹ This test method is under the jurisdiction of ASTM Committee E05 on Fire Standards and is the direct responsibility of Subcommittee E05.15 on Furnishing and Contents.

Current edition approved Sept. 10, 2002. Published November 2002. Originally published as E 1590 – 94. Last previous edition E 1590 – 01.

UL 1056 Fire Test of Upholstered Furniture⁷

UL 1895 Fire Test of Mattresses⁷

2.4 CA Standards:

CA Technical Bulletin 121 Flammability Test Procedure for Mattresses for Use in Public Occupancies⁸

CA Technical Bulletin 129 Flammability Test Procedure for Mattresses for Use in Public Buildings⁸

CA Technical Bulletin 133 Flammability Test Procedure for Seating Furniture for Use in Public Occupancies⁸

2.5 Other Documents:

CFR Part 1632 Standard for the Flammability of Mattresses and Mattress Pads (formerly DOC FF4-72, 40 FR 59940)⁹

Nordtest Method NT Fire 032 Upholstered Furniture: Burning Behavior—Full Scale Test¹⁰

3. Terminology

3.1 *Definitions*—For definitions of terms used in this test method and associated with fire issues, refer to the terminology contained in Terminology E 176 and ISO 3261. In case of conflict, the definitions given in Terminology E 176 shall prevail. For definitions of terms used in this test method and associated with textile issues, refer to the terminology contained in Terminology D 123 and ISO 4880. In case of conflict, the definitions given in Terminology D 123 shall prevail.

3.2 Definitions of Terms Specific to This Standard:

3.2.1 *product, n*—mattress, or mattress with foundation, for which fire-test-response characteristics are to be measured.

3.2.2 *specimen, n*—the manufactured item of the product, or representative prototype of the product.

4. Summary of Test Method

4.1 This fire-test-response test method determines a number of fire-test-response characteristics associated with a full-scale test specimen, mattress or mattress with foundation, ignited with a propane gas burner. Measurements to be made include the rate of heat and smoke release, total amount of heat released, rates and concentrations of carbon oxides released, and rates and amounts of mass of test specimen lost. Other optional measurements are also described.

4.2 In Test Configurations A and B, the test specimen is placed on a weighing platform located in a test room. An exhaust hood, connected to a duct, is located at the doorway of the room.

4.3 In Test Configuration C, the test specimen is placed on a weighing platform located directly under a hood.

4.4 Heat, smoke, and combustion gas release instrumentation is placed in the duct.

4.5 Additional (optional) instrumentation placed in the test room is also described.

5. Significance and Use

5.1 This test method provides a means of measuring a variety of fire-test-response characteristics resulting from burning a test specimen, mattress or mattress with foundation. After ignition using a propane gas burner, the test specimen is permitted to burn freely under well-ventilated conditions. The most important fire-test-response characteristic measured in this test method is the rate of heat release, which quantifies the intensity of the fire generated.

5.2 The rate of heat release is measured by the principle of oxygen consumption. Annex A3 discusses the assumptions and limitations.

5.3 This test method also provides measures of other fire-test-response characteristics, including smoke obscuration (as the rate of smoke release, total smoke released, or optical density of smoke), combustion gas release (as concentrations of combustion gases), and mass loss, which are important to making decisions on fire safety.

5.4 In the majority of fires, the most important gaseous components of smoke are the carbon oxides, present in all fires. They are indicators of the toxicity of the atmosphere and of the completeness of combustion. Measurement of concentrations of carbon oxides are useful for two purposes: (1) as part of fire hazard assessment calculations and (2) to improve the accuracy of heat release measurements. Other toxic combustion gases, which are specific to certain materials, are also indicators of the toxicity of the atmosphere, but are less crucial for determining combustion completeness and are optional measures; however, fire hazard assessment often requires their measurement.

5.5 The type of ignition chosen (flaming source) is common in both accidental and intentional fires in public occupancies. The test method is thus applicable to mattresses in public occupancies. Such facilities include, but are not limited to, health-care facilities, old age convalescent and board and care homes, and college dormitories and residence halls.

5.6 One of the following three configurations is to be used in this test method:

5.6.1 *Test Configuration A*—A test room with the following dimensions: 3.66 by 2.44 by 2.44 m (12 by 8 by 8 ft) high.

5.6.2 *Test Configuration B*—A test room with the following dimensions: 3.66 by 3.05 by 2.44 m (12 by 10 by 8 ft) high.

5.6.3 *Test Configuration C*—An open calorimeter (or furniture calorimeter).

5.7 Rooms of other dimensions are acceptable where it has been shown that equivalent test results are obtained.

5.8 Measurements in the three test configurations listed in 5.6 have been shown to give similar results for heat release in the duct, and mass loss, up to a rate of heat release of 600 kW (1).¹¹

5.9 Measurements of temperatures, gas concentrations, and smoke obscuration in the room are dependent on room size.

5.10 This test method has been designed to provide details for the means to build and operate equipment capable of running tests as required by CA TB 129. However, this test method is more general than that technical bulletin.

⁷ Available from Underwriters Laboratories, Inc., 333 Pfingsten Rd., Northbrook, IL 60062.

⁸ Available from California Bureau of Home Furnishings and Thermal Insulation, State of California, Dept. of Consumer Affairs, 3485 Orange Grove Ave., North Highlands, CA 95660-5595.

⁹ Available from Consumer Product Safety Commission, Washington, DC 20207.

¹⁰ Available from Nordtest, P.O. Box 22, SF-00341, Helsingfors, Finland.

¹¹ The boldface numbers in parentheses refer to the list of references at the end of this test method.

5.11 Studies on the flammability performance of mattresses indicate that bench scale fire tests are useful for preliminary evaluations of component materials for substitution purposes (see Appendix X3).

5.12 Limitations:

5.12.1 This test method is not applicable to ignition by cigarettes, or by any other smoldering source.

5.12.2 The ignition source in this test method is a flaming source, and it has been shown that mattresses, particularly in public occupancies, are involved in fires with flaming ignition sources. Moreover, this particular ignition source has been shown to be able to provide a distinction between different kinds of mattress items. However, the fraction of actual flaming mattress fires occurring with ignitions more or less intense than that used here is not known.

5.12.3 It is not known whether the results of this test method will be equally valid when a mattress is burned under conditions different from those specified. In particular, it is unclear whether the use of a different ignition source, or the same ignition source but having a different duration of flame exposure or a different gas-flow rate, will change the results.

5.12.4 The value of rate of heat release corresponding to the critical limit between propagating mattress fires and non-propagating fires is not known.

5.12.5 As yet, there is not a known direct correlation between smoke obscuration or smoke toxicity measurements in the exhaust duct and overall fire hazard.

6. Apparatus

6.1 Room Layout and Instrumentation:

6.1.1 *Test Room Layout (Test Configuration A)*—The test room shall have dimensions of 2.44 m ± 25 mm by 3.66 m ± 25 mm by 2.44 m ± 25 mm (8 by 12 by 8 ft) high. The room shall have no openings other than a doorway opening 0.76 m ± 6.4 mm by 2.03 m ± 6.4 mm (30 by 80 in.), located as indicated in Fig. 1, and other small openings, as necessary, to make test measurements. Construct the test room of wooden or metal studs, and line it with fire-rated gypsum wallboard or calcium silicate wallboard. Position a hood, as described in Annex A1, outside of the room doorway, such that it collects all of the combustion gases. There shall be no obstructions to the air supply to the test setup.

NOTE 1—Both Type X gypsum wallboard and calcium silicate wallboard with a thickness of at least 13 mm (0.5 in.) have been found acceptable. If the thickness of the wallboard is larger, it will not affect the results of this test method.

6.1.2 *Test Room Layout (Test Configuration B)*—The test room shall have dimensions of 3.05 m ± 25 mm by 3.66 m ± 25 mm by 2.44 m ± 25 mm (10 by 12 by 8 ft) high. The room shall have no openings other than a doorway opening 0.97 m ± 6.4 mm by 2.06 m ± 6.4 mm (38 by 81 in.), located as indicated in Fig. 2, and other small openings, as necessary, to make test measurements. Construct the test room of wooden or metal studs, and line it with fire-rated gypsum wallboard or calcium silicate wallboard. Position a hood, as described in Annex A1, outside of the room doorway, such that it collects all of the combustion gases. There shall be no obstructions to the air supply to the test method setup. (See Note 1.)

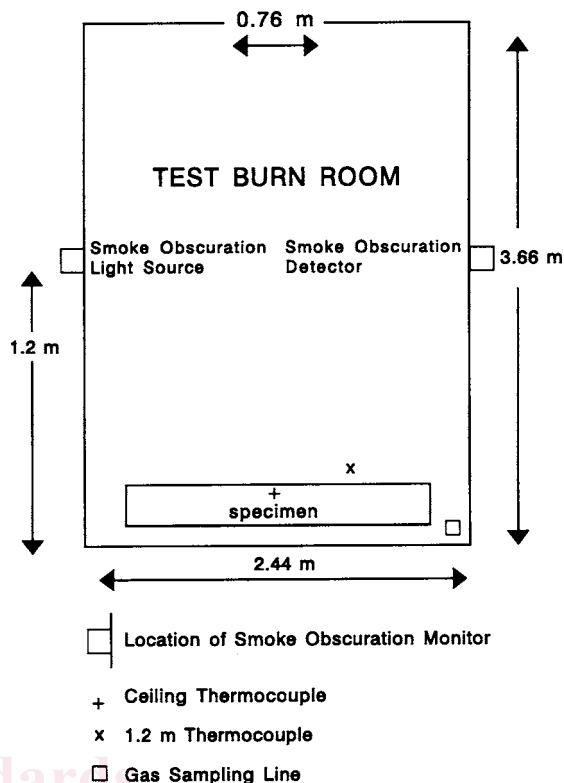

NOTE 1—See text for tolerances; room instrumentation is optional.
FIG. 1 Test Room Configuration A

6.1.3 *Open Calorimeter Layout (Test Configuration C):*

6.1.3.1 The area surrounding the test specimen in an open calorimeter layout shall be sufficiently large that there are no heat radiation effects from the walls or any other nearby objects. The airflow to the test specimen shall be symmetrical from all sides.

6.1.3.2 If the heat release rate of the test specimen is below 600 kW, a load cell sited under a hood, and where the distance between the test specimen and any wall is 1 m (3.3 ft) or more, is acceptable.

6.1.3.3 The air supply to the calorimeter shall be sufficient so that it does not affect the burning process.

6.1.4 *General Discussion of Room Layout*—Heat release measurements in the duct, made in Test Configurations A, B, and C, have been shown to yield similar results for heat release rates below 600 kW (see X1.4) (1).

6.1.5 *Other Test Room Furnishings*—The test room shall contain no furnishings except for the test specimen.

6.1.6 *Location of Test Specimen, for Test Configurations A or B*—Position the test specimen on a weighing platform in a corner. Ensure that the test specimen is at a distance of between 0.10 and 0.25 m (4 and 10 in.) from both walls (Fig. 1 and Fig. 2).

6.1.7 *Location of Test Specimen, for Test Configuration C*—Position the test specimen on a weighing platform underneath the hood (Fig. 3).

6.2 Ignition Source:

6.2.1 As the ignition source, use a gas burner in the shape of a T, as described in Fig. 4.

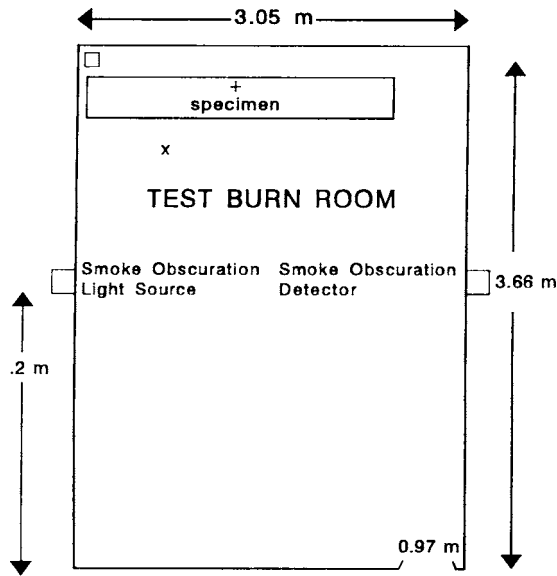

- Location of Smoke Obscuration Monitor
- + Ceiling Thermocouple
- x 1.2 m Thermocouple
- Gas Sampling Line

NOTE 1—See text for tolerances; room instrumentation is optional.

FIG. 2 Test Room Configuration B

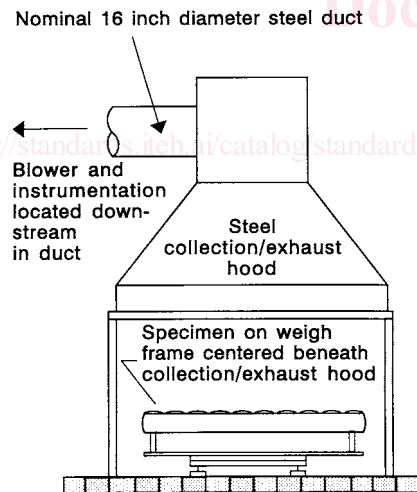
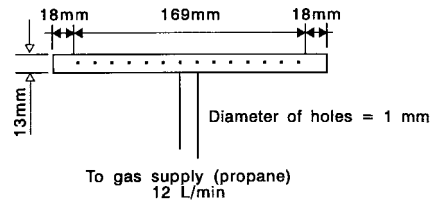
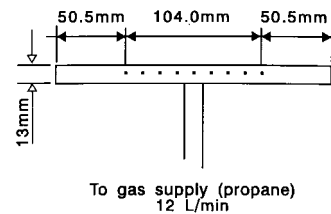

FIG. 3 Test Configuration for Mattress in Furniture Calorimeter

6.2.2 Construct the burner of stainless steel, with wall thicknesses of 0.89 ± 0.05 mm (0.035 ± 0.002 in.). Make the head of the T 205 ± 10 mm (approximately 8 ± 0.4 in.) long and 13 ± 1 mm (0.5 ± 0.04 in.) in outer diameter. Plug the ends of the T. As shown in Fig. 4a and Fig. 4b, construct the burner with two sets of holes equally spaced and centered along the head of the burner and oriented 90° to one another. One set consists of 14 holes and the other of nine holes, with each hole spaced 13 ± 1 mm (0.5 ± 0.04 in.) from the next. Make the holes 1 ± 0.04 mm (0.039 ± 0.002 in.) in diameter.



(a) T-Burner Top View



(b) T-Burner Bottom View

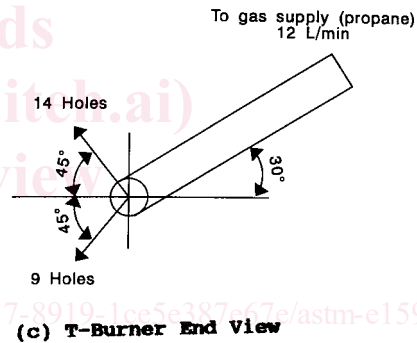

(c) T-Burner End View

NOTE 1—See text for tolerances.

FIG. 4 View of T-shaped Gas Burner: 4a, Burner Head Showing Top Set of Holes; 4b, Burner Head Showing Bottom Set of Holes; and 4c, Side View of Burner Showing Orientation of the Head with the Handle

NOTE 2—**Caution:** It is common for the burner holes to become clogged up following a test. Inspect burner holes after each test, and clean thoroughly, if required. Take care not to enlarge the holes when cleaning them.

6.2.3 Construct the *handle* of the burner of stainless steel, with the same diameter and thickness as the head. Weld it to the head in the orientation shown in Fig. 4c. When the 14 holes in the head are oriented 45° above the horizontal and the nine holes are oriented 45° below the horizontal, the handle is approximately 30° above the horizontal. Construct the handle such that it is at least 450 mm (approximately 18 in.) long, in order to facilitate its attachment to the support and the propane line.

NOTE 3—In order to align the burner to the test specimen properly, it is necessary to position the head as described below; therefore, the angle between the handle and the head is not critical.

6.2.4 Use propane gas, with a known net heat of combustion of 46.5 ± 0.5 MJ/kg, as a fuel for this ignition source. Meter the flow rate of propane at 12 ± 0.25 L/min, at a pressure of 101 ± 5 kPa (standard atmospheric pressure, measured at the flow gage) and a temperature of $20 \pm 5^\circ\text{C}$, or at a flow calculated to be equivalent to these values. To deliver the propane to the burner, use flexible tubing fed into the handle of the burner. Maintain the flow rate of propane constant while the propane gas flame is lit. Mount the burner on an adjustable pole, with a counterweight if necessary, in order to allow the burner to be positioned in the proper location for ignition of the test specimen and then swung out of the way after the propane gas flame is turned off.

6.2.5 The approximate ratio of heat release rate output to gas-flow rate is 1.485 kW min/L under standard conditions. The calculated rate of heat release from the burner at the temperature and pressure given above is 17.8 kW.

6.2.6 Location of Gas Burner:

6.2.6.1 Orient the burner with respect to the test specimen as shown in Fig. 5.

6.2.6.2 Ensure that the horizontal plane of the head of the burner (depicted in Fig. 4c) is level with the bottom horizontal surface of the test specimen. This orientation shall be such that the 14 holes are directed at the test specimen at an angle of 45° above the horizontal and the nine holes are directed under the test specimen (at the mattress or mattress foundation, if one is used) at an angle 45° below the horizontal. The handle will thus be set, nominally, at a 30° angle above the horizontal.

6.2.6.3 Locate the burner during ignition in such a way that the nearest point of the head of the burner is 25 ± 2 mm (1 ± 0.1 in.) from the vertical edge of the test specimen.

6.3 Mass Loss Measurements:

6.3.1 Use a weighing platform to measure the mass of the burning test specimen continuously. Construct a weighing

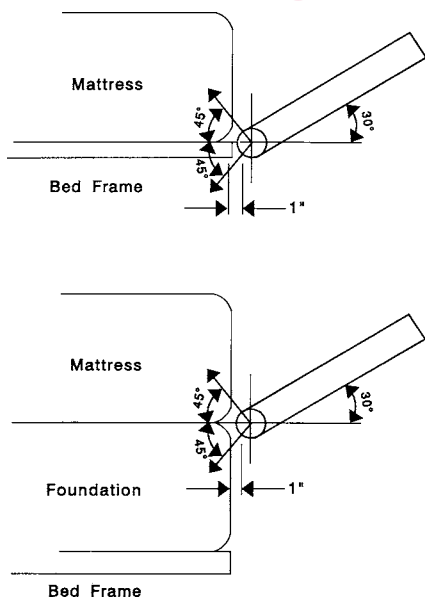

FIG. 5 T-Burner Impingement With And Without A Mattress Foundation

platform, consisting of a horizontal thermal barrier, as described in 6.3.2, and placed on top of a mass measuring device (Fig. 6).

6.3.2 Construct a thermal barrier large enough to prevent melting or falling material from the tested mattress specimen from falling off the thermal barrier. The barrier shall consist of a galvanized steel pan with a gypsum lining placed under the mattress specimen. The barrier shall be used to protect the load cell. The pan shall be constructed of nominally 1.6 mm ($1/16$ in.) thick steel, and have dimensions of 1.2 ± 0.1 by 2.4 ± 0.1 m (4 ft \pm 4 in. by 8 ft \pm 4 in.), with a uniform raised lip of the same material, 100 ± 10 mm (approximately 4 in.) high, on each side, to catch falling material. The bottom of the pan shall be covered by a tight fitting section of standard gypsum board (finish side up), of nominally 13 mm (0.5 in.) thickness. The gypsum board shall be clean before the start of a test; the board shall be replaced for each test.

6.3.3 Measure the test specimen mass continuously with a device capable of an accuracy of no less than ± 150 g, up to at least 90 kg. Install it in such a way that neither the heat from the burning test specimen nor any eccentricity of the load will affect the accuracy. Do not make any range shifts during measurements. Install all parts of the mass measuring device below the top level of the thermal barrier.

6.3.4 The distance from the upper surface of the thermal barrier to floor level shall not exceed 0.3 m (12 in.). The area between the thermal barrier and the floor level shall be shielded, by providing a skirt at the perimeter of the barrier, in order to prevent lifting forces, due to fire-induced air flow, that influence the measurement.

6.3.5 Alternatively, use a suspension-gage weighing system to measure the mass loss of the test specimen in a test room. For this test method, suspend the bed frame from the ceiling with chains (Fig. 7), resulting in penetration through the ceiling of the test room. Keep the hole at the ceiling at an absolute minimum size.

6.4 Exhaust Collection System:

6.4.1 General:

6.4.1.1 Construct the exhaust collection system with the following minimal requirements: a blower, steel hood, duct,

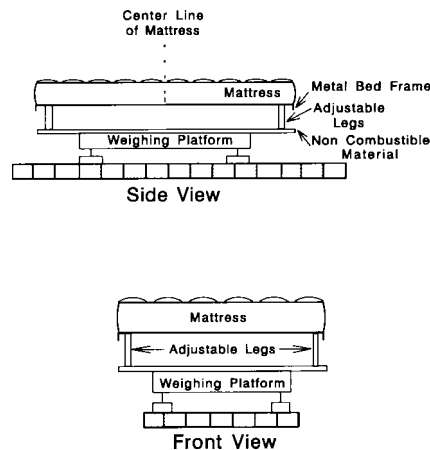

FIG. 6 Setup for Mass Loss Measurement

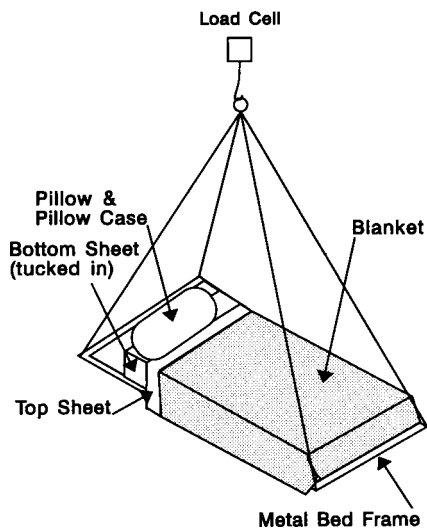

FIG. 7 Bed Assembly With Suspending Strain Gage Load Cell

bidirectional probe, thermocouple(s), oxygen measurement system, smoke obscuration measurement system (white light photocell lamp/detector or laser), and combustion gas sampling and analysis system. Construct the exhaust collection system as shown in Fig. 8 and as explained in Annex A1.

6.4.1.2 Ensure that the system for collecting the smoke (which includes gaseous combustion products) has sufficient exhaust capacity and is designed in such a way that all of the combustion products leaving the burning test specimen are collected. Design the capacity of the evacuation system such that it will exhaust, minimally, all combustion gases leaving the test specimen (see A1.1.4),

6.4.1.3 Place probes for the sampling of combustion gas and measurement of flow rate in accordance with 6.5.

6.4.1.4 Make all measurements of smoke obscuration, gas concentrations, or flow rates at a position in the exhaust duct where the exhaust is mixed uniformly so that there is a nearly uniform velocity across the duct section.

6.4.1.5 To ensure uniform mixing of the exhaust, provide a straight section of duct before the measuring system having a

length equal to at least eight times the inside diameter of the duct. If a measuring system is positioned at a distance of less than 8 diameters, demonstrate the achievement of equivalent results.

6.5 Instrumentation in Exhaust Duct:

6.5.1 The following specifications are minimum requirements for exhaust duct instrumentation. Additional information is given in Annex A2.

6.5.2 Flow Rate—Measure the flow rate in the exhaust duct by means of a bidirectional probe, or an equivalent measuring system, with an accuracy of at least $\pm 6\%$ (see Annex A2 for further details). The response time to a stepwise change of the duct flow rate shall not exceed 5 s to reach 90 % of the final value.

6.6 Combustion Gas Analysis:

6.6.1 Sampling Line— Construct the sampling line tubes of a material not influencing the concentration of the combustion gas species to be analyzed. The following sequence of the gas train has been shown to be acceptable: sampling probe, soot filter, cold trap, gas path pump, vent valve, plastic drying column and carbon dioxide removal columns (if used), flow controller, and oxygen analyzer (see Fig. 9 and Annex A2 for further details). Alternative designs of the sampling line must yield equivalent results. The gas train shall also include appropriate spanning and zeroing facilities.

6.6.2 Oxygen Measurement—Measure the oxygen concentration with an accuracy of ± 0.01 vol % oxygen, or better, in order to have adequate measurements of the rate of heat release. Take the combustion gas sample from the end of the sampling line. Calculate the time delay, including the time constant of the instrument, from the test room; it is a function of the exhaust duct flow rate. This time delay shall not exceed 60 s (see Annex A2 for further details).

6.6.3 Carbon Monoxide and Carbon Dioxide Measurement—Measure the combustion gas species with an instrument having an accuracy of at least ± 0.1 vol % for carbon dioxide and ± 0.02 vol % for carbon monoxide. A suitable output range is from 0 to 1 vol % for carbon monoxide and from 0 to 6 vol % for carbon dioxide. Take the combustion gas sample from the end of the sampling line. Calculate the time delay, including the time constant of the instrument, from the test room; it is a function of the exhaust duct flow rate. It shall be a maximum of 60 s (see Annex A2 for further details).

6.7 Smoke Obscuration Measurement:

6.7.1 Install an optical system for measurement of the light obscuration across the centerline of the exhaust duct. Determine the optical density of the smoke by measuring the light transmitted with a photometer system consisting of a white light source and a photocell/detector or a laser system for measurement of light obscuration across the centerline of the exhaust duct.

6.7.2 One photometer system found suitable consists of a lamp, lenses, an aperture, and a photocell (see Fig. 10 and Annex A2 for further details). Construct the system so that soot deposits on the optics during a test do not reduce the light transmission by more than 5 %.

6.7.3 Alternatively, instrumentation constructed using a 0.5 to 2.0-mW helium-neon laser, instead of a white light system,

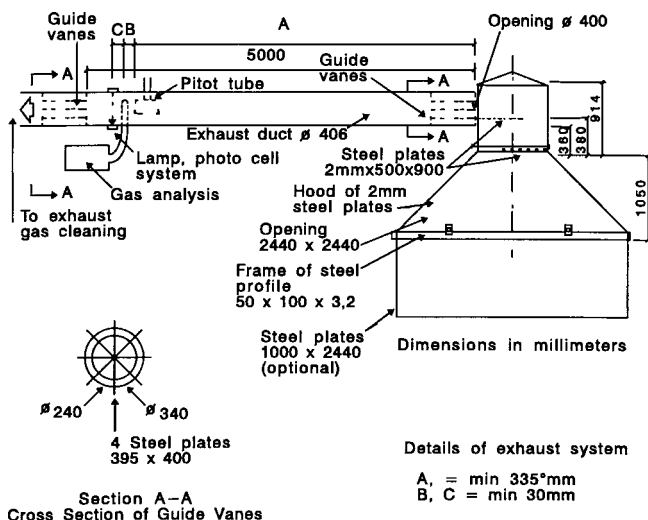

FIG. 8 Design of Hood and Exhaust System

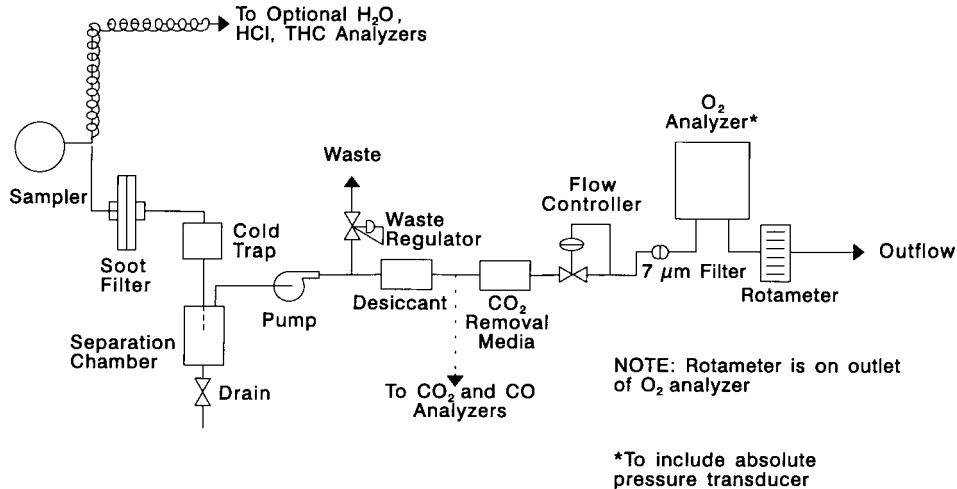

FIG. 9 Schematic of Gas Train

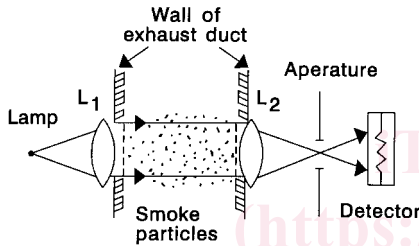

FIG. 10 Optical System Using a White Light

is also acceptable (see Fig. 10 and Annex A2, as well as Fig. 11 and A2.4, for further details). It has been shown that white light and laser systems will provide similar results (see Refs (2-5)).

7. Test Specimen

7.1 As the test specimen, use an actual manufactured mattress, or prototype thereof, in the configuration of its intended use.

7.1.1 Use the foundation in tests of mattresses intended for use with a foundation.

7.1.2 If the foundation consists exclusively of metallic components, it is acceptable to replace it, for the test, by the bed frame described in 7.4.

7.2 The mattress size to be tested is twin, which has the following dimensions: 0.97 by 1.89 m (38.0 by 74.5 in.). Twin size mattresses have varying thicknesses.

7.2.1 If the intended use of the product requires a size different from twin, the test specimen used shall be the size representative of the intended use. Report the dimensions of the test specimen.

7.3 In all respects, the prototype test specimen shall reflect the construction of the actual mattress that it is intended to represent.

7.4 Support the test specimen by means of a metal bed frame. Construct the bed frame of heavy angle-section iron, with all joints welded and with sinusoidal no-sag type springs.

7.5 Ensure that the top surface of the test specimen is not more than 0.9 m (35.4 in.) from the floor.

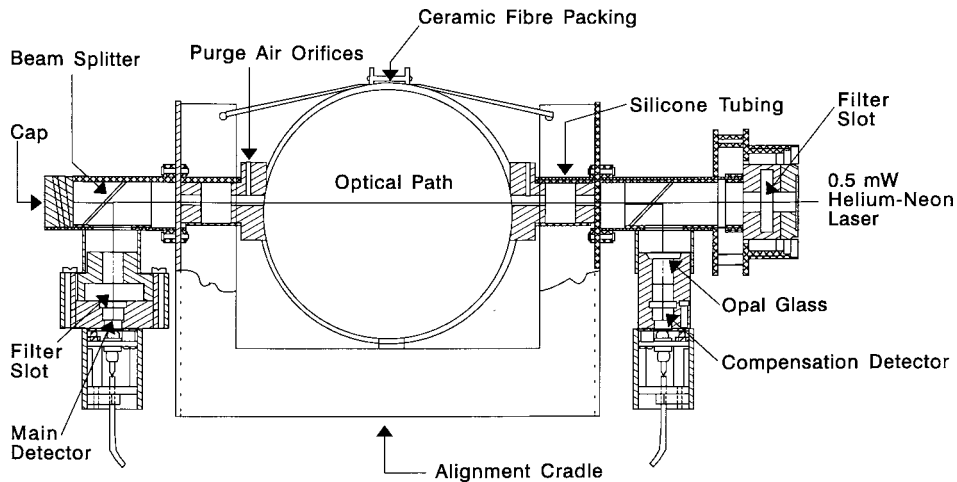

FIG. 11 Laser Extinction Beam

8. Calibration

8.1 Calibrate all instruments carefully with standard sources after initial installation. Among the instruments to be calibrated are load cells or weighing platforms, smoke meters, flow or velocity transducers, and gas analyzers. Perform recalibration tests on the entire system, for example, using standard output burners.

8.2 Heat Release:

8.2.1 Perform the calibration of the heat release instrumentation in the exhaust duct by burning propane or methane gas and comparing the heat release rates calculated from the metered gas input and those calculated from the measured oxygen consumption. The value of net heat of combustion for methane is 50.0 MJ/kg, and that for propane is 46.5 MJ/kg. Position the burner in the same location that the test specimen is to be placed during the test. Measure the gas flow rate at a pressure of 101 ± 5 kPa (standard atmospheric pressure, measured at the flow gage) and a temperature of $20 \pm 5^\circ\text{C}$.

8.2.2 A suitable calibration burner is a sand diffusion burner with a 0.3 by 0.3-m (12 by 12-in.) top surface and a 0.15-m (6-in.) depth. Construct such a gas burner with a 25-mm (1-in.) thick plenum. Alternatively, use a minimum 100-mm (4-in.) layer of Ottawa sand to provide the horizontal surface through which the gas is supplied. This type of burner is shown in Fig. 12. The gas supply to the burner shall be propane, of the same quality as that used for the ignition burner, or methane. The gas

for the burner flame shall not be premixed with air. Meter the flow rate of gas, and keep it constant throughout the calibration test.

8.2.3 Another suitable calibration burner is a pipe, with an inner diameter of 100 ± 1.5 mm (4 in.), supplied with gas from beneath (ISO 9705). The gas for the burner flame shall not be premixed with air.

8.2.4 Obtain a minimum of two calibration points. Obtain a lower heat release rate value of 40 kW and then a higher heat release rate value of 160 kW. Approximate propane flow rates for any required heat release rate value are estimated using the following constant: 1.485 kW min/L, determined at a pressure of 101 ± 5 kPa (standard atmospheric pressure, measured at the flow gage) and a temperature of $20 \pm 5^\circ\text{C}$.

8.2.5 Take measurements at least once every 6 s, and start 1 min prior to ignition of the burner. Determine the average rate of heat release over a period of at least 1 min by (1) the oxygen consumption method and (2) calculating the heat release rate from the gas mass flow rate and the net heat of combustion. The difference between the two values shall not exceed 5 %. This comparison shall be made only after steady-state conditions have been reached.

8.2.6 Perform a calibration test in accordance with to 8.5 prior to each continuous test series. Perform a full basic calibration on a new system or when modifications are introduced.

8.2.7 When calibrating a new system, or modifications are introduced, check the response time of the measuring system by the following test sequence:

Time	Burner output, kW
0 to 5 min	0
5 to 10 min	40
10 to 15 min	160
15 to 20 min	0

The response of the system to a stepwise change of the heat output from the burner shall be a maximum of 12 s to 90 % of final value.

8.2.8 Perform the calibration given in 8.2.7 with the initial duct air flow rate equal to that to be used in the test procedure.

8.2.9 The change in measured rate of heat release, comparing time average values over 1 min, shall not be more than 10 % of the actual heat output from the burner.

8.2.10 The use of a higher rate of heat release for calibration, for example, 500 kW, will generally lead to higher accuracy in the test results.

8.3 Mass Loss—Perform calibration of the mass-measuring device by loading the weighing platform with known masses corresponding to the measuring range of interest, to ensure that the requirements of accuracy in 6.3.3 are fulfilled. Conduct this calibration daily, prior to testing.

8.4 Smoke Obscuration—Calibrate the smoke meter initially to read correctly for two neutral density filters of significantly different values, and also at 100 % transmission. The use of neutral-density filters at 0.5 and 1.0 values of optical density has been shown to be satisfactory for this calibration. Once this calibration is set, only the zero value of extinction coefficient (100 % transmission) must be verified each day, prior to testing. Investigate any excessive departure from the zero line at the end of a test, and correct it.

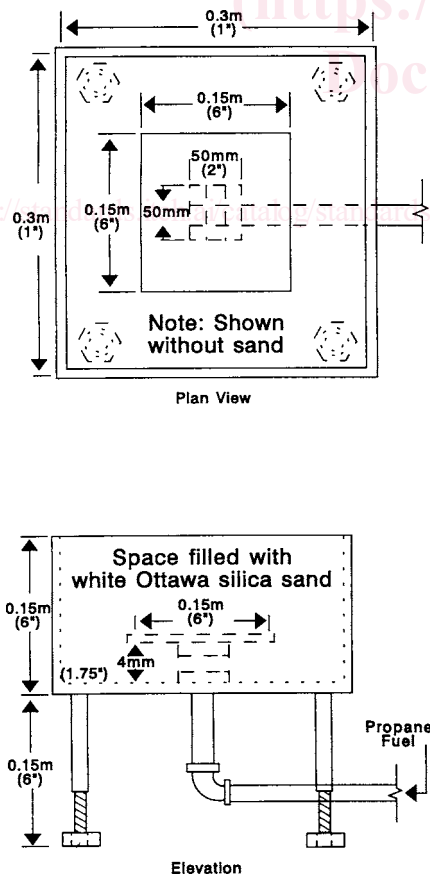

NOTE 1—See text for tolerances.
FIG. 12 Calibration Gas Burner

8.5 *Gas Analysis*— Calibrate the gas analyzers daily, prior to testing (see Guide E 800 for further guidance).

9. Conditioning

9.1 Prior to testing, condition the specimen for at least 48 h in an atmosphere at a temperature of $21 \pm 4^\circ\text{C}$ ($70 \pm 7^\circ\text{F}$) and a relative humidity of less than 60 %. Test the specimens as soon as possible after removal from such conditions if the test room conditions differ from the above. Report the time between removal from conditioning room and the start of testing.

10. Procedure

10.1 Initial Conditions:

10.1.1 The ambient temperature shall be above 15°C (60°F), and the relative humidity shall be below 75 %.

10.1.2 The horizontal air flow, measured at both the surface and a horizontal distance of 0.5 m (20 in.) from the edge of the weighing platform, shall not exceed 0.5 ms^{-1} .

10.1.3 Position the test specimen and metal bed frame centrally on the weighing platform.

10.1.4 Have means available for extinguishing a fully developed fire.

10.2 Test Procedure:

10.2.1 Weigh the test specimen immediately upon removal from the conditioning room and immediately before the start of testing.

10.2.2 Place the T-shaped propane gas burner at the side of the test specimen, as specified in 6.2.6.

10.2.3 Begin all recording and measuring devices 2 min before starting the ignition burner.

10.2.4 Light the ignition burner.

10.2.5 Expose the test specimen to the gas burner flames for 180 s, at a flow rate of 12 L/min, determined at a pressure of $101 \pm 5 \text{ kPa}$ (standard atmospheric pressure, measured at the flow gage) and a temperature of $20 \pm 5^\circ\text{C}$.

10.2.6 Extinguish the gas flame and remove the burner after the specified burning period (180 s).

10.2.7 Perform a photographic or a video recording before and during each test. An indication of elapsed time, giving time to the nearest 1 s, shall appear in all photographic records.

10.2.8 During the test, record the following events and the time when they occur, with respect to the time of ignition of the burner:

10.2.8.1 Ignition of the test specimen,

10.2.8.2 Position of the flame front at various appropriate times,

10.2.8.3 Melting and dripping,

10.2.8.4 Occurrence of pool fire under the test specimen,

10.2.8.5 General description of the burning behavior, and

10.2.8.6 Any other event of special interest.

10.2.9 Terminate the test after the first of the following:

10.2.9.1 All signs of combustion have ceased,

10.2.9.2 One hour of testing has elapsed, or

10.2.9.3 Flashover appears inevitable.

10.2.10 Note, from visual inspection of the specimen after the test, the approximate percentage of each surface that was burned or charred, and the approximate depth of fire damage.

11. Calculation

11.1 Considerations for heat release measurements are presented in Annex A3. Calculate the heat release data using the equations presented in A4.1. The testing laboratory shall choose one of the equations given in A4.1 for calculating heat release, based on the gas analyzers installed.

11.2 Calculate the smoke release data using the equations presented in A4.2.

11.3 Calculate the gas yield data using the equations presented in A4.3.

12. Report

12.1 Report the following descriptive information:

12.1.1 Name and address of the testing laboratory;

12.1.2 Date and identification number of the report;

12.1.3 Name and address of the test requester;

12.1.4 Test configuration used: A, B, or C;

12.1.5 Name of the product manufacturer or supplier, if known;

12.1.6 Name or other identification marks and description of the product;

12.1.7 Density, or mass per unit surface area, total mass, thickness of the main components in the test specimen, and mass of combustible portion of test specimen, if known;

12.1.7.1 Weight change of the test specimen between removal from the conditioning room and the start of testing;

12.1.8 Description of the test specimen, if different from the product;

12.1.9 Conditioning of the test specimen;

12.1.10 Date of the test;

12.1.11 Test number and any special remarks; and

12.1.12 Time between the removal from the conditioning room and the start of testing.

12.2 Report the following test results:

12.2.1 Table of numerical results containing the following:
12.2.1.1 Peak rate of heat release, kW, and the time at which it occurred;

12.2.1.2 Total heat released, MJ;

12.2.1.3 Total heat released at 10 min, MJ;

12.2.1.4 Peak rate of smoke release, m^2s^{-1} , and the time at which it occurred;

12.2.1.5 Total smoke released, m^2 ;

12.2.1.6 Total smoke released at 10 min, m^2 ;

12.2.1.7 Total mass loss, kg;

12.2.1.8 Total mass loss at 10 min, kg;

12.2.1.9 Total percentage of mass loss, %;

12.2.1.10 Peak concentration of carbon monoxide, ppm;

12.2.1.11 Peak temperatures, $^\circ\text{C}$;

12.2.1.12 Equation used to calculate rate of heat release;

12.2.1.13 Peak optical density of smoke (optional);

12.2.1.14 Average optical density of smoke, over the 10-min period, including the peak (optional);

12.2.1.15 Total percentage of combustible mass loss, % (optional);

12.2.1.16 Average yield of carbon monoxide, g CO/g fuel (optional);

12.2.1.17) Average yield of carbon dioxide, g CO₂/g fuel (optional);

12.2.1.18 Carbon monoxide/carbon dioxide molar yield ratio (optional); and

12.2.1.19 Average yield of any other measured combustion gas, g combustion gas/g fuel (optional).

12.2.2 Graphical Results (Optional):

12.2.2.1 Plot of rate of heat release versus time;

12.2.2.2 Plot of rate of smoke release versus time;

12.2.2.3 Plot of optical density versus time;

12.2.2.4 Plot of mass loss versus time;

12.2.2.5 Plot of concentration of carbon monoxide versus time;

12.2.2.6 Plot of concentration of carbon dioxide versus time;

12.2.2.7 Plots of concentration of any other measured combustion gas versus time;

12.2.2.8 Plot of mass flow rate in the exhaust duct versus time;

12.2.2.9 Plot of duct temperature versus time; and

12.2.2.10 Smoke obscuration, carbon monoxide, and temperature measurements in the room in the same fashion, if they have been made.

12.2.3 Descriptive Results:

12.2.3.1 Photographs or videotape of the fire development; and

12.2.3.2 All available information requested in 10.2.8-10.2.10.

13. Precision and Bias

13.1 Precision—An interlaboratory test program was conducted in 1997 using six laboratories. These six laboratories constituted approximately half of all laboratories known to the committee to be capable of executing the test method at the time.¹²

13.1.1 Three replicate samples each of four mattresses were tested. Three samples were polyurethane foam mattress designs with identical construction, but with only the thickness of the polyurethane foam pad varying in each design. The polyurethane foam pads used were 6 mm (¼ in.), 13 mm (½ in.), and 19 mm (¾ in.) thick. The foam pads were covered by identical top and bottom layers of fabric ticking quilted to a polyurethane foam topper pad and a polypropylene netting insulator, separated by a wire coil construction. Borders were slit from the quilt assemblies used for each design.

13.1.2 The fourth sample was one version of a currently manufactured hospital mattress. This mattress consists of identical top and bottom layers of poly (vinyl chloride) mattress ticking (cover reinforced), boric acid powder treated cotton padding, a 15-mm (⅝-in.) polyurethane foam pad, a spring insulator consisting of polypropylene-netting, and an inner spring unit made of wire coil construction.

13.1.3 All major required properties were determined for each construction. A statistical analysis is presented in Table 1 containing precision information for seven fire-test-response characteristics: peak rate of heat release (in kW), total heat released (in MJ), time to peak rate of heat release (in s), total

TABLE 1 Precision Estimates from Interlaboratory Round Robin¹²

	Ave	<i>s_r</i>	<i>S_R</i>	No. of Laboratories
Peak Rate of Heat Release (kW)				
6 mm	153	22.2	62.1	6
13 mm	288	71.2	129.1	6
19 mm ^A	544	216.0	319.4	6
Hospital ^B	185	87.8	138.8	6
Total Heat Released @ 10 min (MJ)				
6 mm	34.2	8.8	13.7	6
13 mm	49.9	15.4	22.0	6
19 mm	63.0	14.7	24.7	6
Hospital ^B	15.8	7.7	19.4	6
Time to Peak Rate of Heat Release (s)				
6 mm	187.1	45.0	49.2	6
13 mm	179.4	23.2	54.1	6
19 mm	146.4	45.5	51.8	6
Hospital ^C	819.8	551.0	551.0	6
Total Mass Loss (kg)				
6 mm	1.64	0.15	0.25	6
13 mm	2.21	0.29	0.47	6
19 mm	2.86	0.25	0.59	6
Hospital ^D	4.04	1.22	1.32	5
Total Smoke Release (m ²)				
6 mm	46.2	18.8	27.5	4
13 mm	77.4	17.2	29.7	4
19 mm	134.8	63.8	63.8	4
Hospital	759.7	160.2	471.8	4
Peak Rate of Smoke Release (m ² /s)				
6 mm	0.29	0.07	0.13	4
13 mm	0.63	0.27	0.35	4
19 mm	1.63	1.01	1.01	4
Hospital	3.06	0.60	2.13	4
Time to Peak Rate of Smoke Release (s)				
6 mm	218.1	67.6	67.6	5
13 mm	188.3	29.3	53.1	5
19 mm	161.2	42.4	44.2	5
Hospital	637.2	478.3	479.1	5

^AOne of the 19-mm (¾-in.) mattresses reached flashover in one test and had a value over three times higher than any other reading. As the test method states that the test shall be terminated "when flashover appears inevitable" that reading was lowered to the flashover value of 1300 kW.

^BOne laboratory reported two test results only with the hospital mattress.

^CTwo laboratories reported two test results only with the hospital mattress.

^DOne laboratory reported two test results only with the hospital mattress.

mass loss (in kg), total smoke released (in m²), peak rate of smoke release (in m²/s) and time to peak rate of smoke release (in s). The statistical parameters presented, calculated with the equations in Practice E 691, are the average of each property from all laboratories (Ave), the repeatability standard deviation (*s_r*), the reproducibility standard deviation (*s_R*), and the number of laboratories reporting each property.

13.2 This is a preliminary study since not all laboratories followed all procedures as detailed in this standard.

13.2.1 The test program encountered a number of problems, which are likely to have contributed to errors in the measurements. Some of the variations are described, in 13.2.1.1 through 13.2.1.4.

13.2.1.1 The tests were conducted in three different types of configurations, namely standard test configurations A, B, and C: two laboratories used configuration A, three laboratories used configuration B and one laboratory used configuration C.

13.2.1.2 The laboratory using configuration C also used sand as a covering on the thermal barrier (see 6.3.2) under the mattress, instead of gypsum board, and a burner with misaligned burner jets. One of the laboratories using configuration B also used misaligned burner jets. The use of sand facilitates

¹² Supporting data is available from ASTM Headquarters. Request RR: E05-1011.