



## Standard Practice for Application of Hose Stream<sup>1</sup>

This standard is issued under the fixed designation E 2226; the number immediately following the designation indicates the year of original adoption or, in the case of revision, the year of last revision. A number in parentheses indicates the year of last approval. A superscript epsilon ( $\epsilon$ ) indicates an editorial change since the last revision or reapproval.

### INTRODUCTION

Several fire-test-response standards (such as ASTM E 119, E 814, E 2074, and E 1966) in order to assess the integrity of building elements after exposure to a specified test fire, require test specimens to be evaluated by exposure to a hose stream. It is important to standardize certain elements of the hose stream to promote uniformity in requirements. To attain this goal, this practice describes a standard apparatus for delivering a solid stream of water and prescribes a standard method of subjecting building elements to a hose stream after fire exposure.

### 1. Scope

1.1 This practice is applicable to building elements required to be subjected to the impact, erosion, and cooling effects of a hose stream as part of a fire-test-response standard. Building elements include, but are not limited to, wall and partition assemblies, fire-resistive joint systems, and doors.

1.2 This practice shall register performance of the building element under specific hose stream conditions. It shall not imply that, either after exposure or under other conditions, the structural capability of the building element is intact or that the building element is suitable for use.

1.3 The result derived from this practice is one factor in assessing the integrity of building elements after fire exposure. The practice prescribes a standard hose stream exposure for comparing performance of building elements after fire exposure and evaluates various materials and construction techniques under common conditions.

1.4 *Units*—The values stated in either SI units or inch-pound units are to be regarded separately as standard. The values stated in each system may not be exact equivalents; therefore, each system shall be used independently of the other. Combining values from the two systems may result in non-conformance with the practice. Within the text, the SI units are shown in brackets.

1.5 The text of this standard references notes which provide explanatory material. These notes shall not be considered as requirements of the standard.

1.6 This standard is used to measure and describe the response of materials, products, or assemblies to heat and flame under controlled conditions, but does not by itself incorporate

all factors required for fire risk assessment of the materials, products, or assemblies under actual fire conditions.

1.7 *This standard does not purport to address all of the safety concerns, if any, associated with its use. It is the responsibility of the user of this standard to establish appropriate safety and health practices and determine the applicability of regulatory limitations prior to use.*

### 2. Referenced Documents

#### 2.1 ASTM Standards:

E 119 Test Methods for Fire Tests of Building Construction and Materials<sup>2</sup>

E 176 Terminology of Fire Standards<sup>2</sup>

E 631 Terminology of Building Constructions<sup>3</sup>

E 814 Test Method of Fire Tests of Through-Penetration Fire Stops<sup>2</sup>

E 1966 Test Method for Fire-Resistive Joint Systems<sup>2</sup>

E 2074 Methods of Fire Tests of Door Assemblies<sup>2</sup>

#### 2.2 UL Standard:

UL 385 Standard for Safety Play Pipes for Water Supply Testing in Fire-Protection Service<sup>4</sup>

### 3. Terminology

3.1 *Definitions*—For definitions of terms used in this practice, refer to Terminologies E 176 and E 631.

#### 3.2 Definitions of Terms Specific to This Standard:

3.2.1 *building element, n*—a component or assembly of materials using products manufactured as independent units capable of being joined with or placed within other components or assemblies to create a structure.

<sup>1</sup> This practice is under the jurisdiction of ASTM Committee E05 on Fire Standards and is the direct responsibility of Subcommittee E05.11 on Fire Endurance.

Current edition approved Aug. 10, 2002. Published November 2002.

<sup>2</sup> *Annual Book of ASTM Standards*, Vol 04.07.

<sup>3</sup> *Annual Book of ASTM Standards*, Vol 04.11.

<sup>4</sup> Available from Underwriters Laboratories (UL), Corporate Progress, 333 Pfingsten Rd., Northbrook, IL 60062.

3.2.2 *exposed area, n*—the total surface area of the test assembly that is subjected to the fire endurance test including, when required, the supporting construction.

3.2.3 *fully developed stream, n*—a coherent, forceful projection of water similar in shape and intensity to the stream being applied to the exposed side of the test assembly from the nozzle.

3.2.4 *supporting construction, n*—construction required for the testing of some building elements into which the test specimen is assembled, for example, the wall into which a door is fitted.

3.2.5 *test assembly, n*—the building element or elements being tested and, if applicable, the supporting construction.

**4. Significance and Use**

4.1 This practice is intended to standardize the apparatus used and the method or pattern of application of a standard hose stream to building elements as one part of the assessment and fire resistance classification of building elements.

4.2 This practice is intended to be used only after a test assembly has completed a prescribed standard fire endurance test.

4.3 The practice exposes a test assembly to a standard hose stream under controlled laboratory conditions.

4.3.1 Water pressure and duration of exposure are not specified in this practice. Duration of exposure, water pressure, and pass/fail criteria are defined in the appropriate fire test method.

4.3.2 This exposure is not intended to replicate typical fire fighting operations or all applied or impact loads a system could be subjected to in field use and conditions.

4.4 Any variation from tested conditions has the potential of substantially changing the performance characteristics determined by this practice.

**5. Apparatus**

5.1 The apparatus used to apply the hose stream is shown in Fig. 1 and shall be capable of delivering a solid stream of water at the pressure specified in the fire endurance test method.

5.1.1 The water stream shall be delivered through a 2-1/2 in. (64 mm) hose discharging through a National Standard Playpipe of corresponding size equipped with a 1-1/8 in. (29 mm) discharge tip of standard taper, smooth-bore pattern without a shoulder at the orifice. Refer to UL 385.

5.1.2 The water pressure at the base of the nozzle shall be measured by providing a 12 in. (305 mm) length of a straight run 2-1/2 in. (64 mm) pipe between the hose and the playpipe. Eight inches downstream from one end, the pipe shall have an 1/8 in. (3.2 mm) diameter pressure tap drilled through the pipe sidewall with a pipe coupling welded or brazed concentrically over the hole. The pressure tap shall be flush with and perpendicular ( $\pm 5^\circ$ ) to the inner wall of the pipe. Burrs or other irregularities shall be removed or corrected.

5.1.3 A pressure gauge calibrated in 1 psi (5 kPa) increments shall be fitted on the end of the coupling. The pressure gauge shall be capable of reading a maximum pressure of at

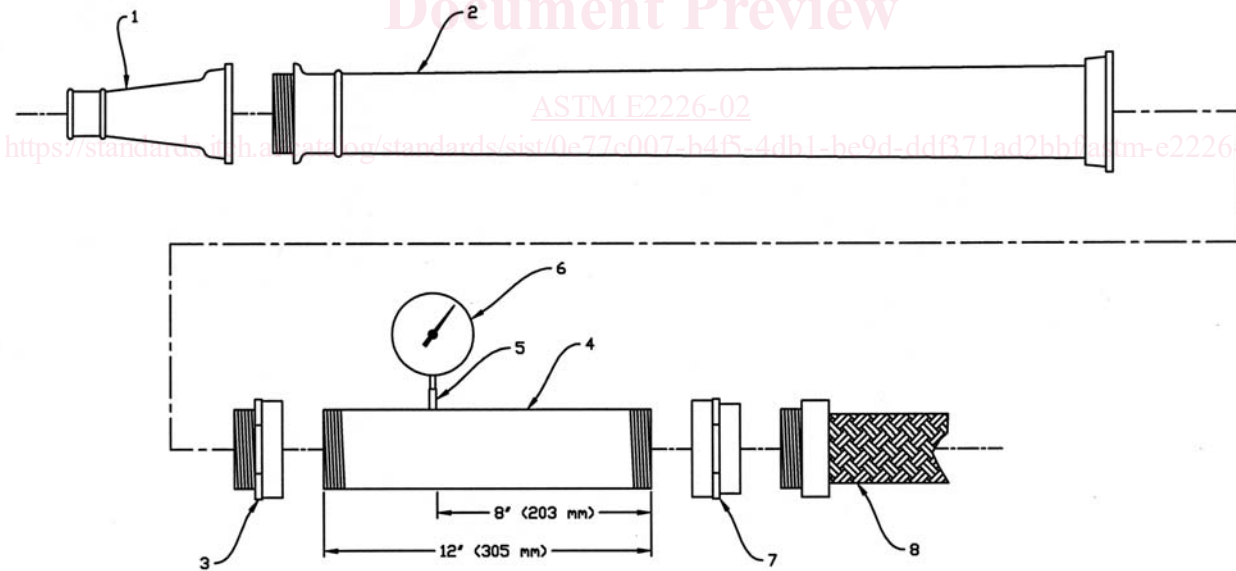

**LEGEND**

- 1. 1-1/8" [29 mm] discharge tip
- 2. 2-1/2" [64 mm] National Standard Playpipe
- 3. Adapter: 2-1/2" [64 mm] hose thread (male) to 2-1/2" [64 mm] NPT (female)
- 4. 2-1/2" [64 mm] standard schedule steel pipe nipple
- 5. Pipe coupling welded or brazed to the nipple, centered over a 1/8" [3.2 mm] hole in nipple
- 6. Pressure gauge
- 7. Adapter: 2-1/2" [64 mm] NPT (female) to 2-1/2" [64 mm] hose thread (female)
- 8. 2-1/2" [64 mm] standard fire hose

FIG. 1 Hose Stream Apparatus