

INTERNATIONAL
STANDARD

ISO
9177-3

First edition
1994-07-01

Mechanical pencils —

Part 3:

Black leads — Bending strengths of HB leads

iTeh STANDARD PREVIEW

(standards.iteh.ai)

Porte-mine —

Partie 3: Mines graphite — Résistance à la flexion des mines HB

<https://standards.iteh.ai/catalog/standards/sist/2812e4d3-a2ad-4873-82ef-1d0444e734ca/iso-9177-3-1994>



Reference number
ISO 9177-3:1994(E)

Foreword

ISO (the International Organization for Standardization) is a worldwide federation of national standards bodies (ISO member bodies). The work of preparing International Standards is normally carried out through ISO technical committees. Each member body interested in a subject for which a technical committee has been established has the right to be represented on that committee. International organizations, governmental and non-governmental, in liaison with ISO, also take part in the work. ISO collaborates closely with the International Electrotechnical Commission (IEC) on all matters of electrotechnical standardization.

Draft International Standards adopted by the technical committees are circulated to the member bodies for voting. Publication as an International Standard requires approval by at least 75 % of the member bodies casting a vote.

International Standard ISO 9177-3 was prepared by Technical Committee ISO/TC 10, *Technical drawings, product definition and related documentation*, Subcommittee SC 9, *Media and equipment for drawing and related documentation*.

ISO 9177 consists of the following parts, under the general title *Mechanical pencils*:

- *Part 1: Classification, dimensions, performance requirements and testing*
- *Part 2: Black leads — Classification and dimensions*
- *Part 3: Black leads — Bending strengths of HB leads*

© ISO 1994

All rights reserved. Unless otherwise specified, no part of this publication may be reproduced or utilized in any form or by any means, electronic or mechanical, including photocopying and microfilm, without permission in writing from the publisher.

International Organization for Standardization
Case Postale 56 • CH-1211 Genève 20 • Switzerland

Printed in Switzerland

Mechanical pencils —

Part 3:

Black leads — Bending strengths of HB leads

1 Scope

This part of ISO 9177 specifies bending strengths and a test method for black leads of HB hardness degree used for mechanical pencils for technical drawings.

2 Normative reference

The following standard contains provisions which, through reference in this text, constitute provisions of this part of ISO 9177. At the time of publication, the edition indicated was valid. All standards are subject to revision, and parties to agreements based on this part of ISO 9177 are encouraged to investigate the possibility of applying the most recent edition of the standard indicated below. Members of IEC and ISO maintain registers of currently valid International Standards.

ISO 9177-2:1989, *Mechanical pencils — Part 2: Black leads — Classification and dimensions*.

3 Definitions

For the purposes of this part of ISO 9177 the definitions given in ISO 9177-2 as well as the following definition apply.

3.1 bending strength: Quality requirement of lead strength as determined by bending the lead to its breaking point, using a prescribed test method and formula.

4 Bending strength

4.1 General

Bending strength of HB leads used for mechanical pencils shall be tested in accordance with clause 5 and shall satisfy the requirements specified in 4.2.

4.2 Bending strength of HB leads for mechanical pencils

The bending strength (σ) shall be not less than the value specified in table 1 corresponding to the respective nominal diameter.

iTeh STANDARD PREVIEW
(standards.iteh.ai)

<https://standards.iteh.ai/catalog/standards/sist/2812e4d3-a2ad-4873-82ef-1d0444c7b4ca/iso-9177-3-1994>

Table 1 — Bending strength of HB leads for mechanical pencils

Lead type	Nominal diameter mm	Minimum bending strength, σ MPa
Polymer (P)	0,35 1)	240
	0,5	190
	0,7	160
	1 1)	95
Ceramic (C)	2	70

1) Current practice is to label or mark mechanical pencils and boxes 0,3 and 0,9 as applicable. The user should note that leads with new standardized designations apply perfectly well to mechanical pencils with the old designations and vice versa; i.e. 0,35 and 1 correspond respectively to 0,3 and 0,9.

5 Test method

Determine the load (F) at which the lead has broken and use this value to calculate the bending strength (σ) according to the following formula:

On a lead sample taken at random, bending strength shall be tested as follows:

$$\sigma = \frac{8Fl}{\pi d^3}$$

Arrange the lead test piece as shown in figures 1 and 2 and apply a load on the lead at a distance halfway between the two supporting anvils at the following rates ($\pm 10\%$):

- 0,5 N/s for 2 mm nominal diameter lead;
- 0,1 N/s for 0,35 mm, 0,5 mm, 0,7 mm and 1 mm nominal diameter leads.

These loading rates shall be verified beforehand using a rigid test piece instead of a lead.

- σ is the bending strength, in megapascals;
- F is the load, in newtons;
- l is the distance, in millimetres, between the two supporting anvils according to table 2;
- d is the actual diameter of the lead, in millimetres.

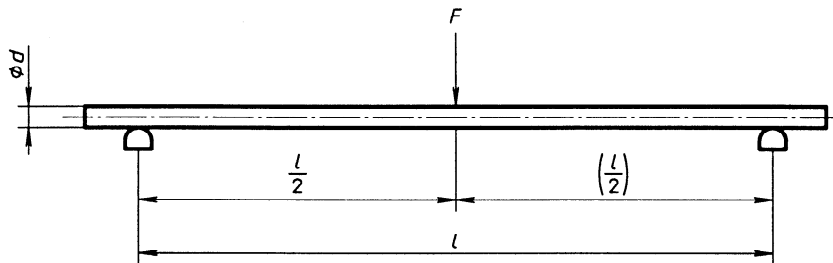

Figure 1 — Arrangement for bending strength test

Dimensions in millimetres

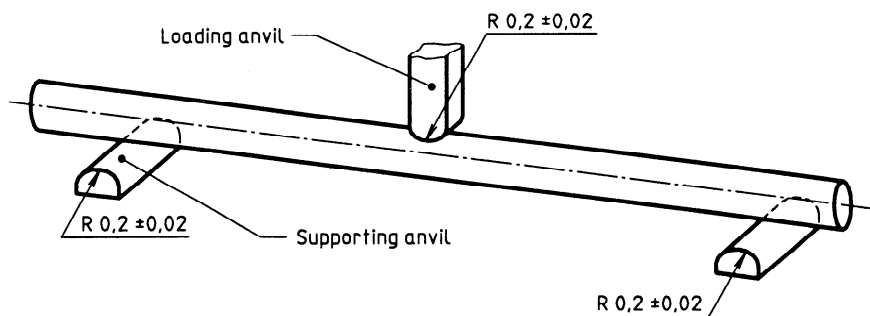

Figure 2 — Anvils for bending strength test

Table 2 — Distance between the two supporting anvils

Dimensions in millimetres

Lead type	Nominal diameter	Distance <i>l</i>
P	0,35; 0,5; 0,7 and 1	20 to 40
C	2	40 to 60

iTeh STANDARD PREVIEW
(standards.iteh.ai)

ISO 9177-3:1994

<https://standards.iteh.ai/catalog/standards/sist/2812e4d3-a2ad-4873-82ef-1d0444e734ca/iso-9177-3-1994>

6 Test report

The test report shall contain the following information:

- a) reference to this part of ISO 9177;
- b) lead type (P or C);
- c) actual diameter (relating to the nominal diameter) of lead under test;

d) test values for *F* and *l*;

- e) bending strength as evaluated according to clause 5;
- f) name of test centre, date and signature of person carrying out the test.

iTeh STANDARD PREVIEW
This page intentionally left blank
(standards.iteh.ai)

[ISO 9177-3:1994](#)

<https://standards.iteh.ai/catalog/standards/sist/2812e4d3-a2ad-4873-82ef-1d0444e734ca/iso-9177-3-1994>

iTeh STANDARD PREVIEW
This page intentionally left blank
(standards.iteh.ai)

[ISO 9177-3:1994](#)

<https://standards.iteh.ai/catalog/standards/sist/2812e4d3-a2ad-4873-82ef-1d0444e734ca/iso-9177-3-1994>

iTeh STANDARD PREVIEW (standards.iteh.ai)

ISO 9177-3:1994

<https://standards.iteh.ai/catalog/standards/sist/2812e4d3-a2ad-4873-82ef-1d0444e734ca/iso-9177-3-1994>

ICS 01.100.40

Descriptors: drawing equipment, pencils, propelling pencils, leads (pencils), specifications, mechanical strength, tests, bend tests, determination, flexural strength.

Price based on 3 pages
