



Standard Test Method for Heat and Visible Smoke Release Rates for Materials and Products Using an Oxygen Consumption Calorimeter¹

This standard is issued under the fixed designation E 1354; the number immediately following the designation indicates the year of original adoption or, in the case of revision, the year of last revision. A number in parentheses indicates the year of last reapproval. A superscript epsilon (ϵ) indicates an editorial change since the last revision or reapproval.

1. Scope

1.1 This fire-test-response standard provides for measuring the response of materials exposed to controlled levels of radiant heating with or without an external ignitor.

1.2 This test method is used to determine the ignitability, heat release rates, mass loss rates, effective heat of combustion, and visible smoke development of materials and products.

1.3 The rate of heat release is determined by measurement of the oxygen consumption as determined by the oxygen concentration and the flow rate in the exhaust product stream. The effective heat of combustion is determined from a concomitant measurement of specimen mass loss rate, in combination with the heat release rate. Smoke development is measured by obscuration of light by the combustion product stream.

1.4 Specimens shall be exposed to heating fluxes in the range of 0 to 100 kW/m². External ignition, when used, shall be by electric spark. The value of the heating flux and the use of external ignition are to be as specified in the relevant material or performance standard (see X1.2). The normal specimen testing orientation is horizontal, independent of whether the end-use application involves a horizontal or a vertical orientation. The apparatus also contains provisions for vertical orientation testing; this is used for exploratory or diagnostic studies only.

1.5 Ignitability is determined as a measurement of time from initial exposure to time of sustained flaming.

1.6 This test method has been developed for use for material and product evaluations, mathematical modeling, design purposes, or development and research. Examples of material specimens include portions of an end-use product or the various components used in the end-use product.

1.7 The values stated in SI units are to be regarded as the standard.

1.8 *This standard is used to measure and describe the response of materials, products, or assemblies to heat and flame under controlled conditions, but does not by itself incorporate all factors required for fire hazard or fire risk*

assessment of the materials, products, or assemblies under actual fire conditions.

1.9 *This standard does not purport to address all of the safety concerns, if any, associated with its use. It is the responsibility of the user of this standard to establish appropriate safety and health practices and determine the applicability of regulatory limitations prior to use. For specific hazard statements, see Section 7.*

2. Referenced Documents

2.1 ASTM Standards:

D 3286 Test Method for Gross Calorific Value of Coal and Coke by the Iso-peribol Bomb Calorimeter²

E 176 Terminology of Fire Standards³

E 177 Practice for Use of the Terms Precision and Bias in ASTM Test Methods⁴

E 662 Test Method for Specific Optical Density of Smoke Generated by Solid Materials³

E 691 Practice for Conducting an Interlaboratory Study to Determine the Precision of a Test Method⁴

E 906 Test Method for Heat and Visible Smoke Release Rates for Materials and Products³

2.2 ISO Standards:

ISO 5657-1986(E) Fire Tests—reaction to fire—ignitability of building materials⁵

ISO 5725 Precision of test methods—determination of repeatability and reproducibility for a standard test method by inter-laboratory tests⁵

3. Terminology

3.1 *Definitions*—For definitions of terms used in this test method, refer to Terminology E 176.

3.2 *Definitions of Terms Specific to This Standard:*

3.2.1 *effective heat of combustion, n*—the measured heat release divided by the mass loss for a specified time period.

3.2.2 *heating flux, n*—the incident flux imposed externally from the heater on the specimen at the initiation of the test.

3.2.2.1 *Discussion*—The specimen, once ignited, is also

¹ This test method is under the jurisdiction of ASTM Committee E05 on Fire Standards and is the direct responsibility of Subcommittee E05.21 on Smoke and Combustion Products.

Current edition approved Nov. 10, 2002. Published December 2002. Originally published as E 1354 – 90. Last previous edition E 1354 – 02c.

² *Annual Book of ASTM Standards*, Vol 05.05.

³ *Annual Book of ASTM Standards*, Vol 04.07.

⁴ *Annual Book of ASTM Standards*, Vol 14.02.

⁵ Available from American National Standards Institute, 11 West 42nd Street, 13th Floor, New York, NY 10036.

heated by its own flame.

3.2.3 *heat release rate, n*—the heat evolved from the specimen, per unit of time.

3.2.4 *ignitability, n*—the propensity to ignition, as measured by the time to sustained flaming, in seconds, at a specified heating flux.

3.2.5 *net heat of combustion, n*—the oxygen bomb (see Test Method D 3286) value for the heat of combustion, corrected for gaseous state of product water.

3.2.6 *orientation, n*—the plane in which the exposed face of the specimen is located during testing, either vertical or horizontal facing up.

3.2.7 *oxygen consumption principle, n*—the expression of the relationship between the mass of oxygen consumed during combustion and the heat released.

3.2.8 *smoke obscuration, n*—reduction of light transmission by smoke, as measured by light attenuation.

3.2.9 *sustained flaming, n*—existence of flame on or over most of the specimen surface for periods of at least 4 s.

3.2.9.1 *Discussion*—Flaming of less than 4 s duration is identified as flashing or transitory flaming.

3.3 *Symbols:*

A_s	= nominal specimen exposed surface area, 0.01 m ² .
C	= calibration constant for oxygen consumption analysis, m ^{1/2} – kg ^{1/2} – K ^{1/2} .
Δh_c	= net heat of combustion, kJ/kg.
$\Delta h_{c,eff}$	= effective heat of combustion, kJ/kg.
I	= actual beam intensity.
I_o	= beam intensity with no smoke.
k	= smoke extinction coefficient, m ⁻¹ .
L	= extinction beam path length, m.
m	= specimen mass, kg.
m_f	= final specimen mass, kg.
m_i	= initial specimen mass, kg.
\dot{m}	= specimen mass loss rate, kg/s.
ΔP	= orifice meter pressure differential, Pa.
q''_{tot}	= total heat released, kJ/m ² (Note that kJ ≡ kW·s).
\dot{q}	= heat release rate, kW.
q''	= heat release rate per unit area, kW/m ² .
q''_{max}	= maximum heat release rate per unit area (kW/m ²).
q''_{180}	= average heat release rate, per unit area, over the time period starting at t_{ig} and ending 180 s later (kW/m ²).
r	= repeatability (the units are the same as for the variable being characterized).
R	= reproducibility (the units are the same as for the variable being characterized).
r_o	= stoichiometric oxygen/fuel mass ratio (–).
s_r	= sample-based standard deviation estimate for repeatability (same units as r).
s_R	= sample-based standard deviation estimate for reproducibility (same units as R).
t	= time, s.
t_d	= oxygen analyzer delay time, s.
t_{ig}	= time to sustained flaming (s).
ρ	= density (kg/m ³).
Δt	= sampling time interval, s.

T_e	= absolute temperature of gas at the orifice meter, K.
\dot{V}	= volume exhaust flow rate, measured at the location of the laser photometer, m ³ /s.
$X_{O_2,0}$	= oxygen analyzer reading, mole fraction O ₂ (–).
$X_{O_2,1}$	= initial value of oxygen analyzer reading (–).
X_{O_2}	= oxygen analyzer reading, before delay time correction (–).
σ_f	= specific extinction area, for smoke, m ² /kg.
σ_r	= repeatability standard deviation (same units as r).
σ_R	= reproducibility standard deviation (same units as R).

4. Summary of Test Method

4.1 This test method is based on the observation (1)⁶ that, generally, the net heat of combustion is directly related to the amount of oxygen required for combustion. The relationship is that approximately 13.1 × 10³ kJ of heat are released per 1 kg of oxygen consumed. Specimens in the test are burned in ambient air conditions, while being subjected to a predetermined external heat flux, which can be set from 0 to 100 kW/m². Burning may be either with or without a spark ignition. The primary measurements are oxygen concentrations and exhaust gas flow rate. Additional measurements include the mass-loss rate of the specimen, the time to sustained flaming and smoke obscuration, or as required in the relevant material or performance standard.

5. Significance and Use

5.1 This test method is used primarily to determine the heat evolved in, or contributed to, a fire involving products of the test material. Also included is a determination of the effective heat of combustion, mass loss rate, the time to sustained flaming, and smoke production. These properties are determined on small size specimens that are representative of those in the intended end use.

5.2 This test method is applicable to various categories of products and is not limited to representing a single fire scenario. Additional guidance for testing is given in X1.2.3 and X1.11.

5.3 This test method is not applicable to end-use products that do not have planar, or nearly planar, external surfaces.

6. Apparatus

6.1 General:

6.1.1 Where explicitly stated in the following description, dimensions are mandatory and should be followed within nominal tolerances of ±1 mm, unless otherwise specified. Such dimensions are followed by an asterisk in Figs. 1-12.

6.1.2 The test apparatus⁷ shall consist essentially of the following components: a conical radiant electric heater, capable of horizontal or vertical orientation; specimen holders, different for the two orientations; an exhaust gas system with oxygen monitoring and flow measuring instrumentation; an

⁶ The boldface numbers in parentheses refer to the list of references at the end of this test method.

⁷ A list of suppliers of this apparatus is available from ASTM Headquarters.

ASTM E 1354 – 02d

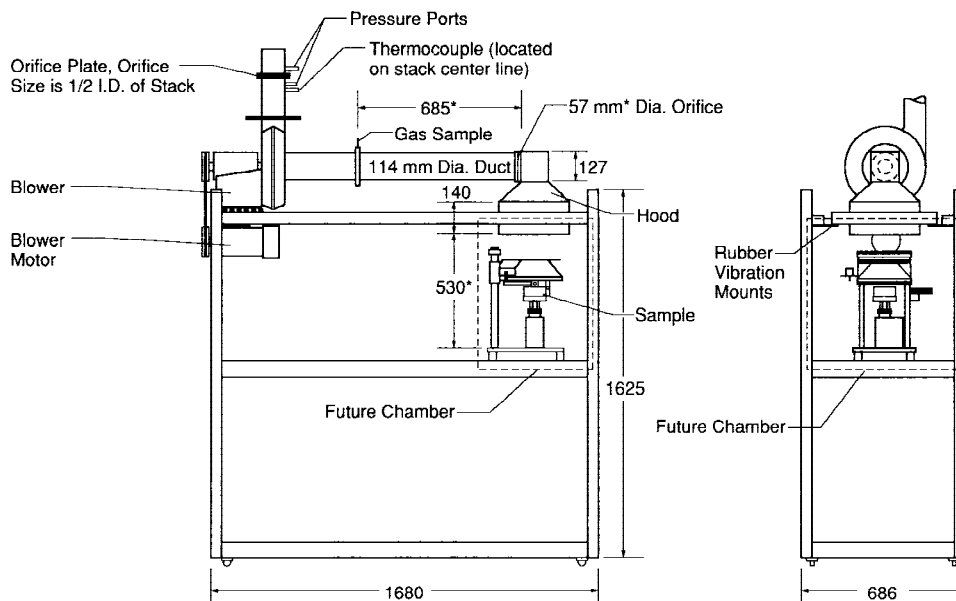

NOTE 1—All dimensions are in millimetres.
NOTE 2—* Indicates a critical dimension.

FIG. 1 Overall View of Apparatus

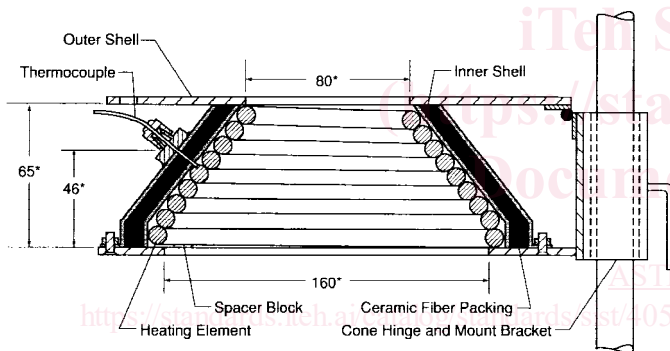

NOTE 1—All dimensions are in millimetres.
NOTE 2—* Indicates a critical dimension.

FIG. 2 Cross-Section View Through the Heater

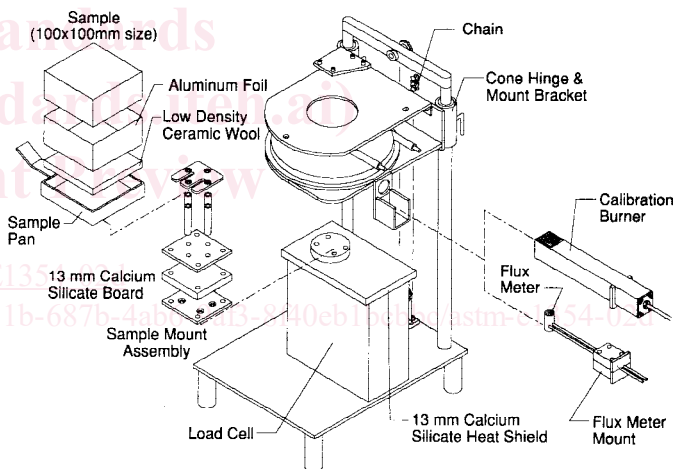

FIG. 3 Exploded View, Horizontal Orientation

electric ignition spark plug; a data collection and analysis system; and a load cell for measuring specimen mass loss. A general view of the apparatus is shown in Fig. 1; a cross section through the heater in Fig. 2; and exploded views of horizontal and vertical orientations in Fig. 3 and Fig. 4.

6.1.3 Additional details describing features and operation of the test apparatus are given in Ref (2).

6.2 Conical Heater:

6.2.1 The active element of the heater shall consist of an electrical heater rod, rated at 5000 W at 240 V, tightly wound into the shape of a truncated cone (Fig. 2 and Fig. 4). The heater shall be encased on the outside with a double-wall stainless steel cone, packed with a refractory fiber material of approximately 100 kg/m³ density.

6.2.2 The heater shall be hinged so it can be swung into either a horizontal or a vertical orientation. The heater shall be capable of producing irradiances on the surface of the specimen of up to 100 kW/m². The irradiance shall be uniform within the central 50 by 50-mm area of the specimen to within

± 2 % in the horizontal orientation and to within ± 10 % in the vertical orientation. As the geometry of the heater is critical, the dimensions on Fig. 2 are mandatory.

6.2.3 The irradiance from the heater shall be capable of being held at a preset level by means of a temperature controller and three type K stainless steel sheathed thermocouples, symmetrically disposed and in contact with, but not welded to, the heater element (see Fig. 2). The thermocouples shall be of equal length and wired in parallel to the temperature controller. The standard thermocouples are sheathed, 1.5 and 1.6 mm outside diameter, with an unexposed hot junction. Alternatively, either 3 mm outside diameter sheathed thermocouples with an exposed hot junction or 1 mm outside diameter sheathed thermocouples with unexposed hot junction can be used.

6.3 Temperature Controller:

6.3.1 The temperature controller for the heater shall be

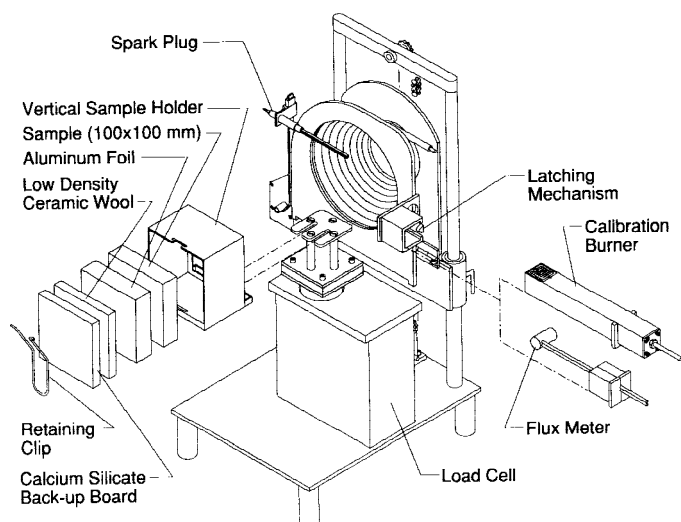

FIG. 4 Exploded View, Vertical Orientation

capable of holding the element temperature steady to within $\pm 2^\circ\text{C}$. A suitable system is a 3-term controller (proportional, integral, and derivative) and a thyristor unit capable of switching currents up to 25 A at 240 V.

6.3.2 The controller shall have a temperature input range of 0 to 1000°C; a set scale capable of being read to 2°C or better; and automatic cold junction compensation. The controller shall be equipped with a safety feature such that in the event of an open circuit in the thermocouple line, it will cause the temperature to fall to near the bottom of its range.

6.3.3 The thyristor unit shall be of the zero crossing and not of the phase angle type.

6.3.4 The heater temperature shall be monitored by a meter capable of being read to $\pm 2^\circ\text{C}$, or better. It shall be permitted to be incorporated into the temperature controller.

6.4 Exhaust System:

6.4.1 The exhaust-gas system shall consist of a high temperature centrifugal exhaust fan, a hood, intake and exhaust ducts for the fan, and an orifice plate flowmeter (Fig. 5). The exhaust system shall be capable of developing flows from 0.012 to 0.035 m³/s.

6.4.2 A restrictive orifice (57 mm inside diameter) shall be located between the hood and the duct to promote mixing.

6.4.3 A ring sampler shall be located in the fan intake duct for gas sampling, 685 mm from the hood (Fig. 1). The ring sampler shall contain twelve holes to average the stream composition with the holes facing away from the flow to avoid soot clogging.

6.4.4 The temperature of the gas stream shall be measured using a 1.0 to 1.6 mm outside diameter sheathed-junction thermocouple or a 3 mm outside diameter exposed junction thermocouple positioned in the exhaust stack on the centerline and 100 mm upstream from the measuring orifice plate.

6.4.5 The flow rate shall be determined by measuring the differential pressure across a sharp-edged orifice (57 mm inside diameter) in the exhaust stack, at least 350 mm downstream from the fan when the latter is located as shown in Fig. 5.

6.4.6 In other details, the geometry of the exhaust system is not critical. Where necessary, small deviations from the recommended dimensions given in Fig. 5 shall be permitted to be

made. The inner diameter of the duct and the orifice plates is not a critical dimension. Also the fan does not need to be at the exact location as indicated on Fig. 5, but shall be permitted to be further downstream, allowing for a more common type of fan to be used. In this case, sufficient undisturbed inflow distances to the gas sampling probe and the measuring orifice shall be provided for the flow to be uniformly mixed.

6.5 *Load Cell*—The general arrangement of the specimen holders on the load cell is indicated in Fig. 3 and Fig. 4. The load cell shall have an accuracy of 0.1 g, and shall have a total weighing range of at least 3.5 kg of which at least 500 g shall be available for direct monitoring during any single test.

6.6 Specimen Mounting:

6.6.1 The horizontal specimen holder is shown in Fig. 6.

6.6.2 The bottom of the horizontal specimen holder shall be lined with a layer of low density (nominal density 65 kg/m³) refractory fiber blanket with a thickness of at least 13 mm. The distance between the bottom surface of the cone heater and the top of the specimen shall be adjusted to be 25 mm. For mechanisms constructed according to the drawing in Fig. 2, this is accomplished by using the sliding cone height adjustment.

6.6.3 The vertical specimen holder is shown in Fig. 7 and includes a small drip tray to contain a limited amount of molten material. A specimen shall be installed in the vertical specimen holder by backing it with a layer of refractory fiber blanket (nominal density 65 kg/m³), the thickness of which depends on specimen thickness, but shall be at least 13 mm thick. A layer of rigid, ceramic fiber millboard shall be placed behind the fiber blanket layer. The millboard thickness shall be such that the entire assembly is rigidly bound together once the retaining spring clip is inserted behind the millboard. In the vertical orientation, the cone heater height is set so the center lines up with the specimen center.

6.6.4 The testing technique to be used when testing intumescent specimens in the horizontal orientation shall be documented in the test report. Options include the retainer frame (Fig. 12) and wire grid (Fig. 8). The edge frame is used to reduce unrepresentative edge burning of specimens while the wire grid is used for retaining specimens prone to delamination. The wire grid shown in Fig. 8 is also suitable for the vertical orientation.

6.7 *Radiation Shield*—The cone heater shall be provided with a removable radiation shield to protect the specimen from the heat flux prior to the start of a test. The shield shall be made of noncombustible material with a total thickness not to exceed 12 mm. The shield shall be one of the following:

(a) water cooled and coated with a durable matte black finish of surface emissivity $e = 0.95 \pm 0.05$ or

(b) not water cooled with a metallic reflective top surface to minimize radiation transfer.

(c) not water-cooled, with a ceramic, non-metallic, surface that minimizes radiation transfer to the specimen surface.

The shield shall be equipped with a handle or other suitable means for quick insertion and removal. The cone heater base plate shall be equipped with the means for holding the shield in position and allowing its easy and quick removal.

6.8 *Ignition Circuit*—External ignition is accomplished by a

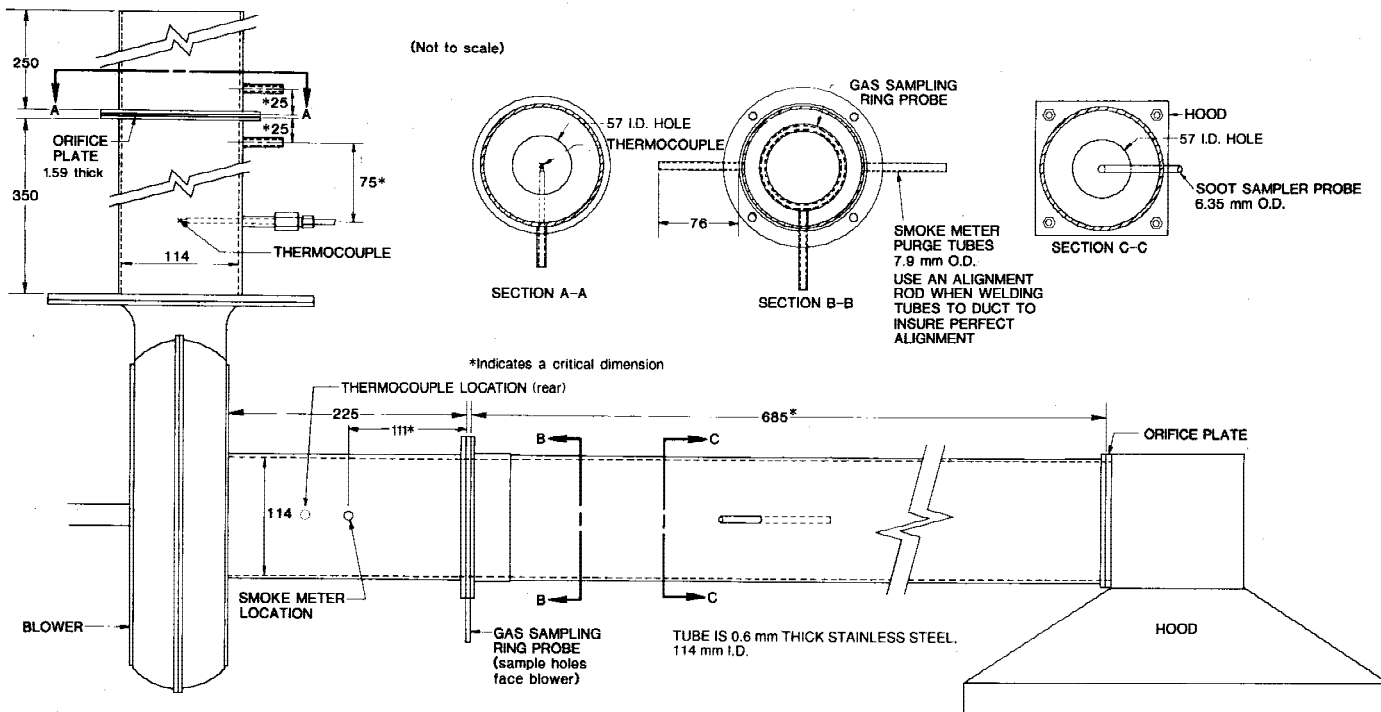

NOTE—All dimensions are in millimetres (not to scale).

NOTE 1—All dimensions are in millimetres (not to scale).

FIG. 5 Exhaust System

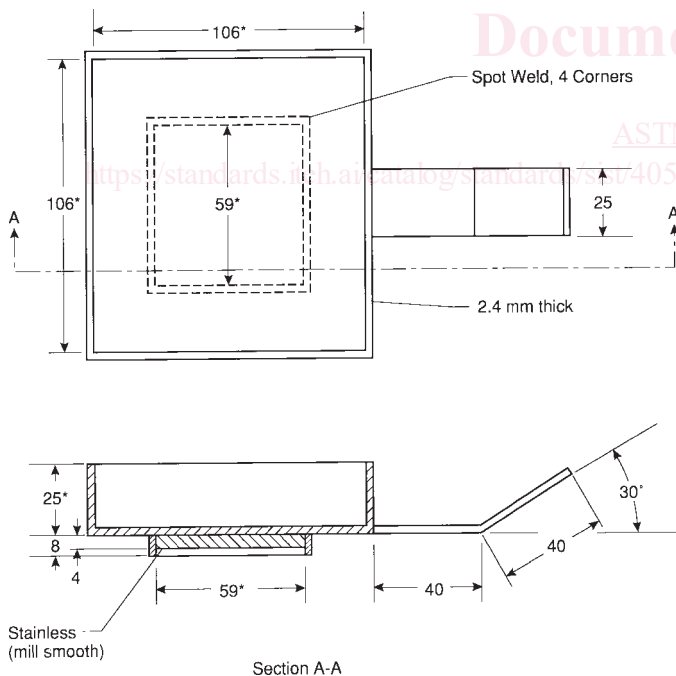

NOTE 1—All dimensions are in millimetres.

NOTE 2—* Indicates a critical dimension.

FIG. 6 Horizontal Specimen Holder

10-kV discharge across a 3-mm spark gap located 13 mm above the center of the specimen in the horizontal location; in the vertical orientation the gap is located in the specimen face

plane and 5 mm above the top of the holder. A suitable power source is a transformer designed for spark-ignition use or a spark generator. The high voltage connections to the spark electrodes shall not be grounded to the chassis in order to minimize interference with the data-transmission lines. For testing with electric spark ignition, spark discharge shall be continuously operating at 50 to 60 Hz until sustained flaming is achieved. The ignitor shall be removed when sustained flaming is achieved.

6.9 Ignition Timer—The timing device for measuring time to sustained flaming shall be capable of recording elapsed time to the nearest second and shall be accurate to within 1 s in 1 h.

6.10 Gas Sampling—Gas sampling arrangements are shown in Fig. 9. They shall incorporate a pump, a filter to prevent entry of soot, a cold trap to remove most of the moisture, a bypass system set to divert all flow except that required for the oxygen analyzer, a further moisture trap, and a trap for carbon dioxide (CO₂) removal; the latter if CO₂ is not measured. When a CO₂ trap is used, the sample stream entering the oxygen analyzer must be fully dry; some designs of CO₂ traps require an additional moisture trap downstream of the CO₂ trap.

NOTE 1—If an optional CO₂ analyzer is used instead of removing CO₂ from the oxygen analyzer stream, the equations to calculate the rate of heat release will be different from those for the standard case (Section 12) and are, instead, given in Annex A1.

6.11 Oxygen Analyzer—The analyzer shall be of the paramagnetic type with a range from 0 to 25 % oxygen. The analyzer shall exhibit a linear response and drift of not more

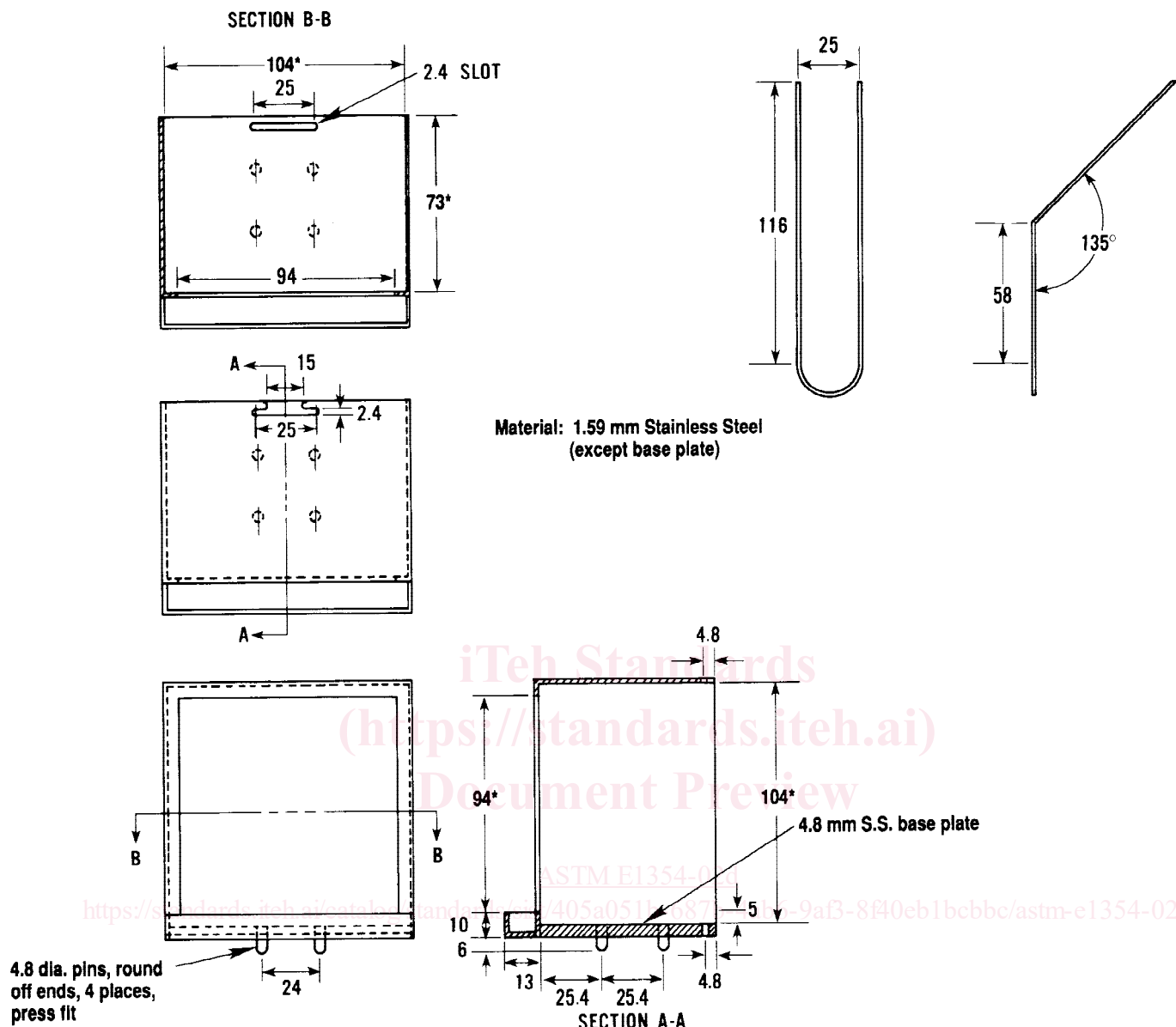

NOTE 1—All dimensions are in millimetres except where noted.
NOTE 2—* Indicates a critical dimension.

FIG. 7 Vertical Specimen Holder

than ± 50 ppm oxygen (root-mean-square value) over a period of $\frac{1}{2}$ h. Since oxygen analyzers are sensitive to stream pressures, the stream pressure shall be regulated (upstream of the analyzer) to allow for flow fluctuations, and the readings from the analyzer compensated with an absolute pressure regulator to allow for atmospheric pressure variations. The analyzer and the absolute pressure regulator shall be located in a constant-temperature environment. The oxygen analyzer shall have a 10 to 90 % response time of less than 12 s.

6.12 Smoke Obscuration Measuring System—The smoke measuring system (Fig. 10) comprises a helium-neon laser, silicon photodiodes as main beam and reference detectors, and appropriate electronics to derive the extinction coefficient and to set the zero reading. The system is designed to be resiliently attached to the exhaust duct by means of refractory gasketing,

at the location shown in Fig. 5. This shall be achieved by one of the following options: (a) the use of an optical bench, or (b) the use of a split yoke mounting comprising two pieces that are rigidly screwed together. The meter is located in place by means of two small-diameter tubes welded onto each side of the exhaust duct. These serve as part of the light baffling for the air purging and also serve to aid in the desposition on the tube walls of any smoke that enters despite the purge flow, so that it does not reach the optical elements.

6.13 Heat Fluxmeter:

6.13.1 The total heat fluxmeter shall be of the Gardon (foil) or Schmidt-Boelter (thermopile) type with a design range of about 100 kW/m^2 . The target receiving radiation, and possibly to a small extent convection, shall be flat, circular, approximately 12.5 mm in diameter, and coated with a durable