



Designation: E716 – 94 (Reapproved 2002)

# Standard Practices for Sampling Aluminum and Aluminum Alloys for Spectrochemical Analysis<sup>1</sup>

This standard is issued under the fixed designation E716; the number immediately following the designation indicates the year of original adoption or, in the case of revision, the year of last revision. A number in parentheses indicates the year of last reapproval. A superscript epsilon ( $\epsilon$ ) indicates an editorial change since the last revision or reapproval.

## 1. Scope

1.1 These practices describe the sampling of aluminum and aluminum-base alloys to obtain a chill-cast disk suitable for quantitative optical emission spectrochemical analysis. The disk in the region to be excited is representative of the melt or product and gives a repeatability of results which approaches that of the reference materials used.

1.2 These practices describe procedures for representative sampling of molten metal, from fabricated or cast products which can be melted, and from other forms which cannot be melted.

1.3 *This standard does not purport to address all of the safety problems, if any, associated with its use. It is the responsibility of the user of this standard to establish appropriate safety and health practices and determine the applicability of regulatory limitations prior to use.* Specific precautionary statements are given in 5.1 and 6.2.

## 2. Referenced Documents

2.1 *ASTM Standards:*<sup>2</sup>

**E101** Test Method for Spectrographic Analysis of Aluminum and Aluminum Alloys by the Point-to-Plane Technique

**E227** Test Method for Optical Emission Spectrometric Analysis of Aluminum and Aluminum Alloys by the Point-to-Plane Technique<sup>3</sup>

**E401** Practice for Bonding Thin Spectrochemical Samples and Standards to a Greater Mass of Material

**E607** Test Method for Atomic Emission Spectrometric Analysis Aluminum Alloys by the Point to Plane Technique Nitrogen Atmosphere

**E1251** Test Method for Analysis of Aluminum and Alumi-

num Alloys by Atomic Emission Spectrometry

## 3. Summary of Practices

3.1 Molten metal representative of the furnace melt is poured into a specified mold to produce a chill-cast disk. The disk is machined to a specified depth that represents the average composition and produces an acceptable surface for excitation.

3.2 Fabricated, cast, or wrought products are remelted and cast into molds, briquetted and remelted, bonded to more massive material, or excited directly without remelting.

3.3 Special practices are included for the sampling and analysis of aluminum-silicon alloys, containing greater than 14 % silicon.

## 4. Significance and Use

4.1 These practices, used in conjunction with the following appropriate quantitative optical emission spectrochemical methods, Test Methods **E101**, **E227**, **E607**, and **E1251**, are suitable for use in manufacturing control, material or product acceptance, and research and development.

## 5. Apparatus

5.1 *Ladle*, capable of holding a minimum of 250 g (8.8 oz) of molten metal, with a handle of sufficient length to reach into a furnace, trough, or crucible. The ladle should be lightly coated with a tightly adhering ladle wash that will not contaminate the sample (**Note 1**).

**NOTE 1—Caution:** Traces of moisture in the coating may cause dangerous spattering.

**NOTE 2—**A suitable ladle wash may be prepared as follows: Mix 255 g (9 oz) of fine whiting ( $\text{CaCO}_3$ ) with 3.8 L (1 gal) of water and boil for 20 min. Add 127 g (4.5 oz) of sodium silicate solution (40 to 42°Bé) and boil for 30 min. Stir well before using.<sup>4</sup>

5.2 *Sample Molds*, capable of producing homogenous chill-cast disks having smooth surfaces, free of surface pockets and porosity. These castings should have a spectrochemical response similar to the reference materials used in preparing the

<sup>1</sup> These practices are under the jurisdiction of ASTM Committee E01 on Analytical Chemistry for Metals, Ores, and Related Materials and are the direct responsibility of Subcommittee E01.04 on Aluminum and Magnesium.

Current edition approved Oct. 10, 2002. Published December 2002. Originally approved in 1980. Last previous edition approved in 1994 as E716 – 94. DOI: 10.1520/E0716-94R02.

<sup>2</sup> For referenced ASTM standards, visit the ASTM website, www.astm.org, or contact ASTM Customer Service at service@astm.org. For *Annual Book of ASTM Standards* volume information, refer to the standard's Document Summary page on the ASTM website.

<sup>3</sup> Withdrawn. The last approved version of this historical standard is referenced on www.astm.org.

<sup>4</sup> Other proprietary ladle washes such as Dycote, available from Fosco, Inc., P. O. Box 8728, Cleveland, OH 44135; and Zirconite, available from Titanium Alloy Mfg. Co., 111 Broadway, New York, NY 10006, have been found suitable for this purpose.

analytical curves and must have a repeatability from excitation-to-excitation of no more than 2 % relative on major elements. They must be representative of the melt in the region excited. Several types of molds have been found acceptable:

5.2.1 *Type A*, book mold, is shown in Fig. 1. The advantage of this mold is simplicity and low cost. This mold produces a vertically cast disk with the sprue on its edge. The mold dimensions are such as to produce a disk approximately 64 mm (2.5 in.) in diameter by 6 to 8 mm (0.24 to 0.32 in.) in thickness. A circular central recess 15 to 25 mm (0.6 to 1.0 in.) in diameter on one side of the disk facilitates machining of that side in preparation for excitation. It also promotes more uniform freezing of the raised peripheral area. The mold material should be steel or cast iron and should weigh approximately 2 to 3 kg (5 to 7 lb).

5.2.2 *Type B*, center-pour mold, is shown in Fig. 2. The advantage of this mold is that the sample obtained may be excited around the entire annular area. This mold produces a horizontally cast disk with the sprue over the center on the back side. The mold dimensions are such as to produce a disk approximately 64 mm (2.5 in.) in diameter by 6 to 13 mm (0.24 to 0.50 in.) in thickness. A circular central recess 10 to 20 mm (0.4 to 0.8 in.) in diameter on one side of the disk facilitates machining of that side in preparation for excitation. It also promotes more uniform freezing of the raised peripheral area, but the corresponding raised portion of the mold must not be so large as to restrict the throat for the sprue. A slight taper, 1 to 2 deg, on the hinged portion of the mold facilitates opening when a disk has been cast. The mold material should be steel or cast iron and should weigh approximately 3.5 to 4.5 kg (8 to 10 lb).

NOTE 3—Prepare the surface of the mold cavity to minimize the formation of gas pockets on the surface of the castings and to resist rusting of the mold cavity surface. To do this, blast the inner surface with a sharp grit that cuts rather than peens. The resulting finely roughened face is essential for obtaining a smooth and uniform surface on the cast disk. Next, degrease the mold, place in a cold furnace, and raise the temperature to 400°C (752°F). At this temperature and throughout the remainder of the heating cycle, introduce steam into the furnace. Raise the temperature to 540°C (1004°F) and maintain for 4 h. The resulting black oxide coating is tenacious and of a dull black appearance.

5.2.2.1 *Special Type B Mold*, which produces a disk 6 mm (0.24 in.) thick, is required for undiluted aluminum-silicon alloys containing greater than 14 % silicon.

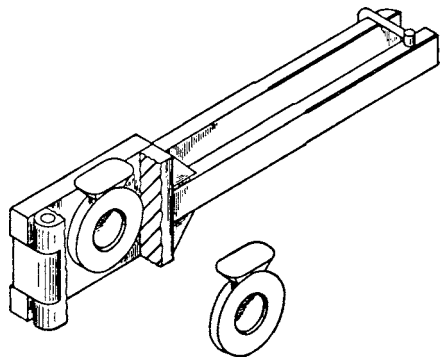

**FIG. 1 Type A Mold and Sample**

5.2.3 *Vacuum Mold*<sup>5</sup> is shown in Fig. 4. This mold produces disks that are 38 mm (1.5 in.) in diameter and 13 mm (0.5 in.) thick and weigh approximately 40 g (1.4 oz). The mold consists of a solid copper base and a porous bronze wall in the form of a composite mold insert which is located in a steel mold body. A graphite coated cast iron tip is attached to the mold body by a spring clamp assembly. The vacuum source can be either a small battery-operated vacuum pump or a rubber syringe connected to the mold body.

5.2.4 *Other Types of Molds*—Other molds of different types, materials, and dimensions may be substituted provided that the uniformity of the samples so obtained is comparable to the uniformity of samples obtained from Type A or B molds, and furthermore that such samples have a spectrochemical response similar to the reference materials used for preparing the analytical curve.

5.3 *Lathe*, capable of machining a smooth flat surface and having automatic cross feed. A milling machine may also be used.

5.4 *Tool Bits*—Either alloy steel or cemented carbide is recommended. The best shape of the tool varies with the type and speed of the lathe, but in general, soft metals require less top and side rake than steel. For example, for pure aluminum, a top rake of 0° and a side rake of 0 to 6° should prove satisfactory. Also a side clearance of about 6° and a front clearance of 15° should be satisfactory for all aluminum disk samples. The nose of the tool should be rounded. A tool bit design that has been found satisfactory for most aluminum alloys is shown in Fig. 5.

5.5 *Portable Electric Melting Furnace*,<sup>6</sup> equipped with a graphite crucible with a minimum capacity of 200 g (7.1 oz) of molten aluminum, and capable of maintaining temperatures for melting aluminum alloys.

## 6. Materials

6.1 *Graphite Rods*—6.15 by 300-mm (0.242 by 12-in.) spectroscopic electrodes are satisfactory.

6.2 *Phosphorus*, red, amorphous.

NOTE 4—**Caution:** Provide adequate ventilation when phosphorus is added to molten metal.

## 7. Preparation of Samples

### 7.1 Molten Metal:

#### 7.1.1 Chill-Cast Disk by Molds A or B:

7.1.1.1 When a furnace or crucible of molten metal is to be sampled, the temperature must be well above the point at which any solid phase could be present. Using the ladle or a separate skimming tool, coated with a dry, tightly adhering mold wash (Note 2) and free of any remaining previous metal, push any dross away from the sampling area. Next, dip the ladle sideways into the clear area well below the surface and stir momentarily. Then turn the ladle upright, and quickly withdraw. Two things are thus accomplished, namely, heating

<sup>5</sup> A portable Vacuum Sampler, available from Aluminum Company of America, Alcoa Center, PA 15069, has been found suitable for this purpose.

<sup>6</sup> A Jelrus Handy-Melt furnace and graphite crucible, available from Cole-Parmer Instrument Co., 7425 North Oak Park Ave., Chicago, IL 60648, has been found suitable for this purpose.