



Designation: D 665 – 02

An American National Standard



Designation: 135/93

Standard Test Method for Rust-Preventing Characteristics of Inhibited Mineral Oil in the Presence of Water¹

This standard is issued under the fixed designation D 665; the number immediately following the designation indicates the year of original adoption or, in the case of revision, the year of last revision. A number in parentheses indicates the year of last reapproval. A superscript epsilon (ϵ) indicates an editorial change since the last revision or reapproval.

This standard has been approved for use by agencies of the Department of Defense.

1. Scope

1.1 This test method is used to evaluate the ability of inhibited mineral oils, particularly steam-turbine oils, to aid in preventing the rusting of ferrous parts should water become mixed with the oil. This test method is also used for testing other oils, such as hydraulic oils and circulating oils. Provision is made in the procedure for testing heavier-than-water fluids.

NOTE 1—For synthetic fluids, such as phosphate ester types, the plastic holder and beaker cover should be made of a chemically resistant material, such as polytetrafluoroethylene (PTFE).

1.2 *This standard does not purport to address all of the safety concerns, if any, associated with its use. It is the responsibility of the user of this standard to establish appropriate safety and health practices and determine the applicability of regulatory limitations prior to use.* For specific precautionary statements, see 6.4–6.6.

2. Referenced Documents

2.1 ASTM Standards:

- A 108 Specification for Steel Bars, Carbon, Cold-Finished, Standard Quality²
- A 240/A 240M Specification for Chromium and Chromium-Nickel Stainless Steel Plate, Sheet, and Strip for Pressure Vessels and for General Applications³
- D 91 Test Method for Precipitation Number of Lubricating Oils⁴

- D 1193 Specification for Reagent Water⁵
- D 2422 Classification of Industrial Fluid Lubricants by Viscosity System⁴
- D 3603 Test Method for Rust-Preventing Characteristics of Steam Turbine Oil in the Presence of Water (Horizontal Disk Method)⁶
- D 4057 Practice for Manual Sampling of Petroleum and Petroleum Products⁶
- E 1 Specification for ASTM Thermometers⁷
- Motor Fuels, Section I, Annex A2, Reference Materials and Blending Accessories⁸
- 2.2 *Other Documents:*
 - Specifications-IP Standard Thermometers, Appendix A⁹
 - Specifications for IP Standard Reference Liquids, Appendix B⁹
 - SAE Standard J 405 Chemical Composition of SAE Wrought Stainless Steels¹⁰
 - BS 871 Specification for abrasive papers and cloths⁹
 - BS 970: Part 1: Carbon and Carbon Manganese Steels Including Free Cutting Steels⁹

3. Summary of Test Method

3.1 A mixture of 300 mL of the oil under test is stirred with 30 mL of distilled water or synthetic sea water, as required, at a temperature of $60 \pm 1^\circ\text{C}$ ($140 \pm 2^\circ\text{F}$) with a cylindrical steel test rod completely immersed therein. It is recommended to run the test for 4 h; however, the test period may, at the discretion of the contracting parties, be for a shorter or longer period. The test rod is observed for signs of rusting and, if desired, degree of rusting.

¹ This test method is under the jurisdiction of ASTM Committee D02 on Petroleum Products and Lubricants and is the direct responsibility of Subcommittee D02.C0.02 on Corrosion and Water/Air Separability.

Current edition approved Nov. 10, 2002. Published December 2002. Originally approved in 1942. Last previous edition approved in 1999 as D 665–99.

In the IP, this test method is under the jurisdiction of the Standardization Committee. This test method was adopted as a joint ASTM–IP standard in 1964.

² *Annual Book of ASTM Standards*, Vol 01.05.

³ *Annual Book of ASTM Standards*, Vol 01.03.

⁴ *Annual Book of ASTM Standards*, Vol 05.01.

⁵ *Annual Book of ASTM Standards*, Vol 11.01.

⁶ *Annual Book of ASTM Standards*, Vol 05.02.

⁷ *Annual Book of ASTM Standards*, Vol 14.03.

⁸ *Annual Book of ASTM Standards*, Vol 05.05.

⁹ *Annual Book of IP Standard Methods for Analysis and Testing of Petroleum and Related Products*, Vol 2.

¹⁰ *1995 SAE Handbook*, Vol 1.

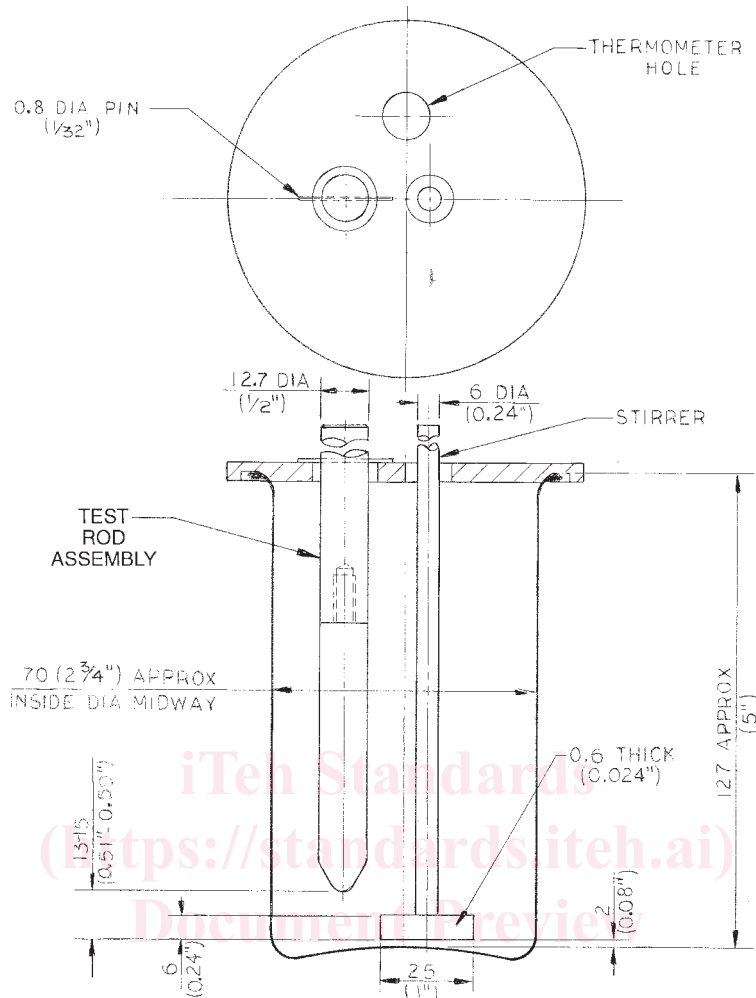

NOTE—All units are in millimetres, unless otherwise specified.

FIG. 1 Rusting Test Apparatus

NOTE 2—Until 1999 it was customary to run the test for 24 h. A round robin with comparisons of different test times showed that no statistically significant differences in rating were found for any sample, between the 4 and 24 h results.¹¹

4. Significance and Use

4.1 In many instances, such as in the gears of a steam turbine, water can become mixed with the lubricant, and rusting of ferrous parts can occur. This test indicates how well inhibited mineral oils aid in preventing this type of rusting. This test method is also used for testing hydraulic and circulating oils, including heavier-than-water fluids. It is used for specification of new oils and monitoring of in-service oils.

NOTE 3—This test method was used as a basis for Test Method D 3603. Test Method D 3603 is used to test the oil on separate horizontal and vertical test rod surfaces, and can provide a more discriminating evaluation.

¹¹ Supporting data (results of the cooperative test program with modified test duration) have been filed at ASTM International Headquarters and may be obtained by requesting Research Report RR: D02-1474.

5. Apparatus

5.1 *Oil Bath*—A thermostatically controlled liquid bath capable of maintaining the test sample at a temperature of $60 \pm 1^\circ\text{C}$ ($140 \pm 2^\circ\text{F}$) (see Note 4). An oil having a viscosity of approximately ISO VG 32 (see Classification D 2422) is suitable for the bath. The bath shall have a cover with holes to accommodate the test beakers.

NOTE 4—ASTM Thermometer 9C (9F), as prescribed in Specification E 1, or IP Thermometer 21C in accordance with IP Volume 2, Appendix A, is suitable to indicate the temperature. Alternatively, calibrated thermocouples may be used.

5.2 *Beaker*—A 400-mL, Berzelius-type, tall-form heat-resistant glass¹² beaker without pourout, as shown in Fig. 1, approximately 127 mm (5 in.) in height measured from the inside bottom center and approximately 70 mm ($2\frac{3}{4}$ in.) in inside diameter measured at the middle.

5.3 *Beaker Cover*—A flat beaker cover of glass or poly (methyl methacrylate) (PMMA) (Note 5), kept in position by

¹² Borosilicate glass is satisfactory for this purpose.

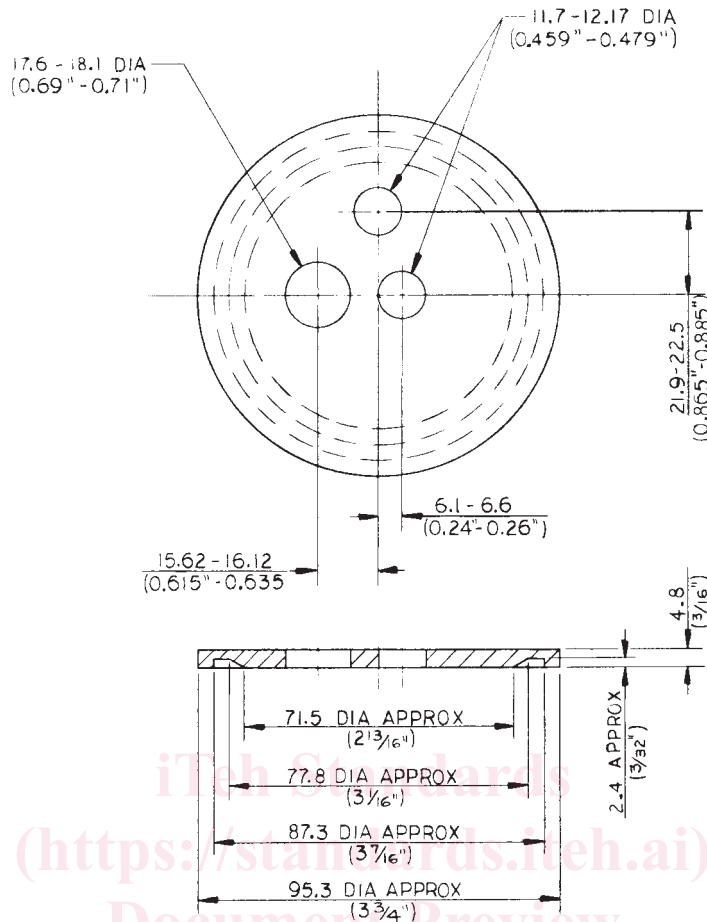

NOTE—All units are in millimetres, unless otherwise specified.

FIG. 2 Beaker Cover

ASTM D665-02

suitable means such as a rim or groove. Two holes shall be provided on any diameter of the cover; one for a stirrer 12 mm (¹⁵/₃₂ in.) in diameter with its center 6.4 mm (¹/₄ in.) from the center of the cover; and the other, on the opposite side of the center of the cover, for the test rod assembly (see Section 8), 18 mm (⁴⁵/₆₄ in.) in diameter with its center 16 mm (⁵/₈ in.) from the center of the cover. In addition, a third hole 12 mm (¹⁵/₃₂ in.) in diameter shall be provided for a temperature measuring device, with its center 22.5 mm (⁷/₈ in.) from the center of the cover and on a diameter of the cover at right angles to the diameter through the other two holes.

NOTE 5—An inverted petri dish makes a suitable cover, as the sides of the dish aid in keeping it in position. Fig. 2 shows a PMMA resin cover for the beaker which has been found to be suitable. An optional feature is shown, consisting of a slot, 1.6 by 27 mm (¹/₁₆ by ^{1 1}/₁₆ in.), which is centered on a diameter of the stirrer hole at right angles to the cover diameter through the test rod hole and stirrer hole. This feature allows withdrawal of the stirrer while the beaker cover is in place. When the test method test is used for other fluids such as synthetics, the beaker cover should be made from chemically resistant material such as polymonochlorotrifluoroethylene (PCTFE).

5.4 The plastic holder shall be made of PMMA resin in accordance with the dimensions shown in Fig. 3 (two types of

holders are illustrated). When testing synthetic fluids, the plastic holder should be made from chemically resistant material such as polytetrafluoroethylene (PTFE).

5.5 *Stirrer*—A stirrer constructed entirely from stainless steel (Note 6 and Note 7) in the form of an inverted T. A flat blade 25 by 6 by 0.6 mm (1 by 0.24 by 0.024 in.) shall be attached to a 6-mm (0.24-in.) rod in such a way that the blade is symmetrical with the rod and has its flat surface in the vertical plane.

NOTE 6—A suitable material is an 18 % chromium, 8 % nickel alloy steel conforming to Type 304, of Specification A 240/A 204M, or SAE No. 30304 (see SAE J405), or BS 970: Part 1: 1983: 302S31.⁹

NOTE 7—If stainless steel is not obtainable, stirrers made of heat-resistant glass¹² and having approximately the same dimensions as the stainless steel stirrers specified can be used.

5.6 *Stirring Apparatus*—Any convenient form of stirring apparatus capable of maintaining a speed of 1000 ± 50 rpm.

5.7 *Grinding and Polishing Equipment*—A 150-grit⁹ (99-µm) and a 240-grit⁹ (58-µm) in accordance with BS 871 or its equivalent, metalworking aluminum oxide abrasive cloth coat

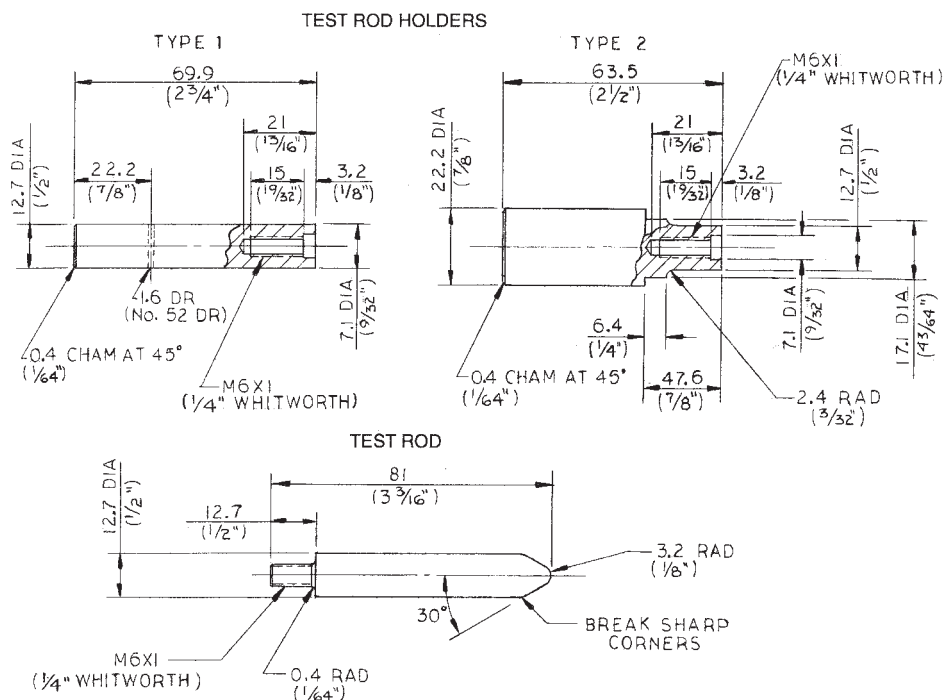

NOTE—All units are in millimetres, unless otherwise specified.

FIG. 3 Test Rod and Holders

on a jeans backing, a suitable chuck (see Fig. 4) for holding the test rod, and a means of rotating the test rod at a speed of 1700 to 1800 rpm.

5.8 *Oven*, capable of maintaining a temperature of 65°C (150°F).

6. Reagents and Materials

6.1 *Purity of Reagents*—Reagent grade chemicals shall be used in all tests. Unless otherwise indicated, it is intended that all reagents conform to the specifications of the Committee on Analytical Reagents of the American Chemical Society where such specifications are available.¹³ Other grades may be used, provided it is first ascertained that the reagent is of sufficiently high purity to permit its use without lessening the accuracy of the determination.

6.2 *Purity of Water*—Unless otherwise indicated, references to water shall be understood to mean reagent water as defined by Type II of Specification D 1193.

6.3 The synthetic sea water shall have the following composition:

Salt	g/L
NaCl	24.54
MgCl ₂ ·6H ₂ O	11.10
Na ₂ SO ₄	4.09
CaCl ₂	1.16
KCl	0.69
NaHCO ₃	0.20
KBr	0.10
H ₃ BO ₃	0.03
SrCl ₂ ·6H ₂ O	0.04
NaF	0.003

6.3.1 The solution can be conveniently prepared as follows. This procedure avoids any precipitation in concentrated solutions with subsequent uncertainty of complete resolution. Using certified pure (cp) chemicals and distilled water, prepare the following stock solutions:

Stock Solution No. 1:	
MgCl ₂ ·6H ₂ O	3885 g
CaCl ₂ (anhydrous)	406 g
SrCl ₂ ·6H ₂ O	14 g
Dissolve and dilute to 7 L	

Stock Solution No. 2:	
KCl	483 g
NaHCO ₃	140 g
KBr	70 g
H ₃ BO ₃	21 g
NaF	2.1 g
Dissolve and dilute to 7 L	

¹³ *Reagent Chemicals, American Chemical Society Specifications*, American Chemical Society, Washington, DC. For suggestions on the testing of reagents not listed by the American Chemical Society, see *Analar Standards for Laboratory Chemicals*, BDH Ltd., Poole, Dorset, U.K., and the *United States Pharmacopeia and National Formulary*, U.S. Pharmacopeial Convention, Inc. (USPC), Rockville, MD.