

INTERNATIONAL
STANDARD

ISO
9974-3

First edition
1996-04-15

**Connections for general use and fluid
power — Ports and stud ends with ISO 261
threads with elastomeric or metal-to-metal
sealing —**

(Part 3: Standards.iteh.ai)

Stud ends with metal-to-metal sealing (type B)

ISO 9974-3:1996

<https://standards.iteh.ai/catalog/standards/sist/98e3d463-8b7f-46fe-9406-c9d50a0ea793/iso-9974-3-1996>

Raccordements pour applications générales et transmissions hydrauliques et pneumatiques — Orifices et éléments mâles à filetage ISO 261 et joint en élastomère ou étanchéité métal sur métal —

Partie 3: Éléments mâles avec étanchéité métal sur métal (type B)



Reference number
ISO 9974-3:1996(E)

Foreword

ISO (the International Organization for Standardization) is a worldwide federation of national standards bodies (ISO member bodies). The work of preparing International Standards is normally carried out through ISO technical committees. Each member body interested in a subject for which a technical committee has been established has the right to be represented on that committee. International organizations, governmental and non-governmental, in liaison with ISO, also take part in the work. ISO collaborates closely with the International Electrotechnical Commission (IEC) on all matters of electrotechnical standardization.

Draft International Standards adopted by the technical committees are circulated to the member bodies for voting. Publication as an International Standard requires approval by at least 75 % of the member bodies casting a vote.

International Standard ISO 9974-3 was prepared jointly by Technical Committees ISO/TC 5, *Ferrous metal pipes and metallic fittings*, Subcommittee SC 5, *Threaded or plain end butt-welding fittings, threads, gauging of threads*, and ISO/TC 131, *Fluid power systems*, Subcommittee SC 4, *Connectors and similar products and components*.

ISO 9974 consists of the following parts under the general title *Connections for general use and fluid power — Ports and stud ends with ISO 261 threads with elastomeric or metal-to-metal sealing*.

- Part 1: *Threaded ports*
- Part 2: *Stud ends with elastomeric sealing (type E)*
- Part 3: *Stud ends with metal-to-metal sealing (type B)*

The performance requirements, dimensions and designs are defined for port and stud end connections for the L and S series in ISO 9974-2 and for the LL, L and S series in ISO 9974-3. Significant testing over more than 30 years of use has confirmed the performance requirements of these port and stud end connections.

Stud ends conforming to ISO 9974-2 and 9974-3 are identical to those conforming to DIN 3852-1. ISO 9974-2 stud ends are used on ISO 8434-1 and ISO 8434-4 fittings, and ISO 9974-3 stud ends are used on ISO 8434-1 fittings.

Annex A forms an integral part of this part of ISO 9974. Annex B is for information only.

© ISO 1996

All rights reserved. Unless otherwise specified, no part of this publication may be reproduced or utilized in any form or by any means, electronic or mechanical, including photocopying and microfilm, without permission in writing from the publisher.

International Organization for Standardization
Case Postale 56 • CH-1211 Genève 20 • Switzerland

Printed in Switzerland

Introduction

In fluid power systems, power is transmitted and controlled through a fluid (liquid or gas) under pressure within an enclosed circuit. In general applications, a fluid may be conveyed under pressure.

Components are connected through their threaded ports by stud ends on fluid conductor fittings to tubes and pipes or to hose fittings and hoses.

iTeh STANDARD PREVIEW (standards.iteh.ai)

[ISO 9974-3:1996](https://standards.iteh.ai/catalog/standards/sist/98e3d463-8b7f-46fe-9406-c9d50a0ea793/iso-9974-3-1996)

<https://standards.iteh.ai/catalog/standards/sist/98e3d463-8b7f-46fe-9406-c9d50a0ea793/iso-9974-3-1996>

iTeh STANDARD PREVIEW
This page intentionally left blank
(standards.iteh.ai)

ISO 9974-3:1996

<https://standards.iteh.ai/catalog/standards/sist/98e3d463-8b7f-46fe-9406-c9d50a0ea793/iso-9974-3-1996>

Connections for general use and fluid power — Ports and stud ends with ISO 261 threads with elastomeric or metal-to-metal sealing —

Part 3:

Stud ends with metal-to-metal sealing (type B)

1 Scope

This part of ISO 9974 specifies dimensions, performance requirements and test procedures for heavy-duty (S series), light-duty (L series) and extra-light-duty (LL series) stud ends with ISO 261 threads and metal-to-metal sealing. It also specifies the designation of these stud ends. These stud ends should not be used for leak-free hydraulic fluid power applications because they may leak if re-used.

Stud ends in accordance with this part of ISO 9974 may be used at working pressures up to 10 MPa (100 bar¹⁾) for the LL series, 25 MPa (250 bar) for the L series and 40 MPa (400 bar) for the S series. The permissible working pressure depends upon the stud end size, materials, design, working conditions, application, etc.

For threaded ports and stud ends specified in new designs in hydraulic fluid power applications, only ISO 6149 is to be used. Threaded ports and stud ends in accordance with ISO 1179, ISO 9974 and ISO 11926 are not to be used for new designs in hydraulic fluid power applications.

Conformance to the dimensional information in this part of ISO 9974 does not guarantee rated performance. Each manufacturer should perform testing according to the specification contained in this part of ISO 9974 to assure that components comply with the performance ratings.

2 Normative references

The following standards contain provisions which, through reference in this text, constitute provisions of this part of ISO 9974. At the time of publication, the editions indicated were valid. All standards are subject to revision, and parties to agreements based on this part of ISO 9974 are encouraged to investigate the possibility of applying the most recent editions of the standards indicated below. Members of IEC and ISO maintain registers of currently valid International Standards.

ISO 261:—²⁾, *ISO general-purpose metric screw threads — General plan.*

ISO 3448:1992, *Industrial liquid lubricants — ISO viscosity classification.*

ISO 4759-1:1978, *Tolerances for fasteners — Part 1: Bolts, screws and nuts with thread diameters between 1,6 (inclusive) and 150 mm (inclusive) and product grades A, B and C.*

ISO 5598:1985, *Fluid power systems and components — Vocabulary.*

ISO 6508:1986, *Metallic materials — Hardness test — Rockwell test (scales A - B - C - D - E - F - G - H - K).*

ISO 6803:1994, *Rubber or plastics hoses and hose assemblies — Hydraulic pressure impulse test without flexing.*

1) 1 bar = 0,1 MPa = 10⁵ Pa; 1 MPa = 1 N/mm²

2) To be published. (Revision of ISO 261:1973)

3 Definitions

For the purposes of this part of ISO 9974, the definitions given in ISO 5598 apply.

4 Dimensions

Stud ends shall conform to the dimensions shown in figure 1 and given in table 1. Hex tolerances across flats shall be in accordance with ISO 4759-1, product grade C.

5 Requirements

5.1 Working pressure

Stud ends made of low carbon steel shall be designed for use at the working pressures given in table 2.

5.2 Performance

Stud ends made of low carbon steel shall meet at least the burst and impulse pressures given in table 2, when tested in accordance with clause 7.

6 Metal-to-metal sealing

The machined seal edge is compressed during assembly. This causes damage to the sealing face of the port. Safe re-assembly is not possible. A high surface pressure shall also be obtained, otherwise leakage is possible.

7 Test methods

Parts used for the cyclic endurance or burst test shall not be tested further, used or returned to stock.

7.1 Burst pressure test

7.1.1 Principle

Test three samples to confirm that stud ends in accordance with this part of ISO 9974 meet or exceed a ratio of 4:1 between the relevant burst and working pressures.

7.1.2 Materials

Test blocks shall be unplated and hardened to 45 HRC to 50 HRC (see ISO 6508). Stud ends shall be made from low carbon steel and plated.

7.1.3 Procedure

7.1.3.1 Thread lubrication

For testing only, threads and contact surfaces shall be lubricated with hydraulic oil with a viscosity of VG 32 in accordance with ISO 3448 prior to the application of torque.

7.1.3.2 Stud end torque

Test stud ends after application of the torques given in table 3.

7.1.3.3 Pressure rise rate

During the burst test, the rate of pressure rise shall not exceed 138 MPa/min (1 380 bar/min).

7.1.4 Test report

Test results and conditions shall be reported on the test data form given in annex A.

7.2 Cyclic endurance (impulse) test

7.2.1 Principle

Test six samples at their respective impulse pressures.

7.2.2 Materials

Use the same materials as those given in 7.1.2.

7.2.3 Procedures

7.2.3.1 Thread lubrication

Apply lubricant as specified in 7.1.3.1.

7.2.3.2 Stud end torques

Apply torque as specified in 7.1.3.2.

7.2.3.3 Cycle and pressure rise rate

The cycle rate shall be uniform between 0,5 Hz and 1,3 Hz and shall conform to the wave pattern shown in ISO 6803, except that the pressure rise rate shall be adjusted accordingly.

iTeh STANDARD PREVIEW
(standard not final)
ISO 9974-3:1996
<https://standards.iteh.ai/catalog/standards/sist/98e3d463-8b7f-46fe-9406-c9d50a0ea793/iso-9974-3-1996>

Surface roughness in micrometres

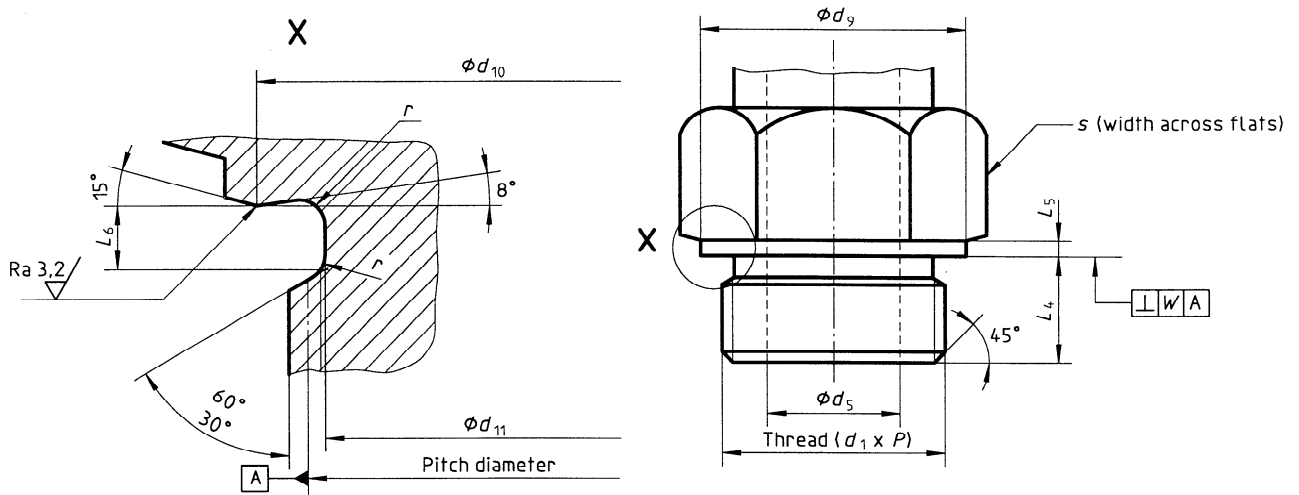

Figure 1 — Stud end with metal-to-metal sealing (type B)

Table 1 — Dimensions of stud ends with metal-to-metal sealing (type B)

iTeh STANDARD PREVIEW

Dimensions in millimetres

Thread ($d_1 \times P$)	d_5		d_{10}		d_{11}		L_4	L_5	L_6	r	s	W
	nom. 1)	tol. 2)	nom. 1)	tol. 2)	nom. 1)	tol. 2)						
M8 × 1	3	$+0,14$ 0	—	—	12	11	8	1,5	2	1	12	0,1
M10 × 1	4,5	$+0,18$ 0	4	$+0,18$ 0	—	—	8					
M12 × 1,5	—	—	6	$+0,18$ 0	4	$+0,18$ 0	12	2	—	—	17	
M14 × 1,5	—	—	7	$+0,22$ 0	5	$+0,18$ 0	12					
M16 × 1,5	—	—	9	$+0,22$ 0	7	$+0,22$ 0	12	3	1,2	—	22	
M18 × 1,5	—	—	11	$+0,27$ 0	8	$+0,22$ 0	12					
M20 × 1,5 ³⁾	—	—	—	—	10	$+0,22$ 0	14	3	—	—	27	
M22 × 1,5	—	—	14	$+0,27$ 0	12	$+0,27$ 0	14					
M26 × 1,5	—	—	18	$+0,27$ 0	—	—	16	4	1,6	—	32	
M27 × 2	—	—	—	—	16	$+0,27$ 0	16					
M33 × 2	—	—	23	$+0,33$ 0	20	$+0,33$ 0	18	3	—	—	41	
M42 × 2	—	—	30	$+0,33$ 0	25	$+0,33$ 0	20					
M48 × 2	—	—	36	$+0,39$ 0	32	$+0,39$ 0	22					

1) Maximum nominal diameter.
 2) Tolerance corresponding to H13 in accordance with ISO 286-2.
 3) For measurement applications.

Table 2 — Pressures for stud ends with metal-to-metal sealing (type B)

Series	Thread	Working pressure		Test pressure			
		MPa	(bar)	Burst		Impulse ¹⁾	
		MPa	(bar)	MPa	(bar)	MPa	(bar)
LL	M8 × 1	10	(100)	40	(400)	13,3	(133)
	M10 × 1	10	(100)	40	(400)	13,3	(133)
L	M10 × 1	25	(250)	100	(1 000)	33,2	(332)
	M12 × 1,5	25	(250)	100	(1 000)	33,2	(332)
	M14 × 1,5	25	(250)	100	(1 000)	33,2	(332)
	M16 × 1,5	25	(250)	100	(1 000)	33,2	(332)
	M18 × 1,5	25	(250)	100	(1 000)	33,2	(332)
	M22 × 1,5	16	(160)	64	(640)	21,3	(213)
	M26 × 1,5	16	(160)	64	(640)	21,3	(213)
	M33 × 2	10	(100)	40	(400)	13,3	(133)
	M42 × 2	10	(100)	40	(400)	13,3	(133)
	M48 × 2	10	(100)	40	(400)	13,3	(133)
S	M12 × 1,5	40	(400)	160	(1 600)	53,2	(532)
	M14 × 1,5	40	(400)	160	(1 600)	53,2	(532)
	M16 × 1,5	40	(400)	160	(1 600)	53,2	(532)
	M18 × 1,5	40	(400)	160	(1 600)	53,2	(532)
	M20 × 1,5 ²⁾	40	(400)	160	(1 600)	53,2	(532)
	M22 × 1,5	40	(400)	160	(1 600)	53,2	(532)
	M27 × 2	40	(400)	160	(1 600)	53,2	(532)
	M33 × 2	25	(250)	100	(1 000)	33,2	(332)
	M42 × 2	16	(160)	64	(640)	21,3	(213)
	M48 × 2	16	(160)	64	(640)	21,3	(213)

NOTE — These pressures were established using fittings made of low carbon steel when tested in accordance with clause 7.

1) Cyclic endurance test pressure.
2) For measurement applications.

Table 3 — Torques for stud end qualification test

Series	Thread	Torque N·m + 10 % 0
LL	M8 × 1	10
	M10 × 1	15
L	M10 × 1	20
	M12 × 1,5	30
	M14 × 1,5	50
	M16 × 1,5	70
	M18 × 1,5	90
	M22 × 1,5	150
	M26 × 1,5	210
	M33 × 2	380
	M42 × 2	550
M48 × 2	700	
S	M12 × 1,5	45
	M14 × 1,5	60
	M16 × 1,5	90
	M18 × 1,5	120
	M20 × 1,5	170
	M22 × 1,5	190
	M27 × 2	320
	M33 × 2	450
	M42 × 2	600
M48 × 2	800	

NOTE — These torque values are for testing only. Assembly tightening torque depends on many factors, including lubrication, coating and surface finish. The manufacturer shall be consulted.

7.2.4 Requirements

The six samples tested shall pass a cyclic endurance test of 1 000 000 cycles.

7.2.5 Test report

Test results and conditions shall be reported on the test data form given in annex A.

8 Designation of stud ends

The stud ends shall be designated by

- a) "Stud end";
- b) reference to this part of ISO 9974, i.e. 9974-3;
- c) thread size ($d_1 \times P$);
- d) stud end series [heavy duty (S), light duty (L) or extra-light duty (LL)].

EXAMPLE

Stud end ISO 9974-3 - M10 × 1,5 S

9 Identification statement (Reference to this part of ISO 9974)

Use the following statement in test reports, catalogues and sales literature when electing to comply with this part of ISO 9974:

"Stud ends with metal-to-metal sealing conform to ISO 9974-3:1996, *Connections for general use and fluid power — Ports and stud ends with ISO 261 threads with elastomeric or metal-to-metal sealing — Part 3: Stud ends with metal-to-metal sealing (type B).*"