

INTERNATIONAL
STANDARD

ISO
11926-1

First edition
1995-05-01

**Connections for general use and fluid
power — Ports and stud ends with ISO 725
threads and O-ring sealing —**

Part 1:

Ports with O-ring seal in truncated housing

iTeh STANDARD PREVIEW
(standards.iteh.ai)

*Raccordements pour applications générales et transmissions hydrauliques
et pneumatiques — Orifices et éléments mâles à filetage ISO 725 et joint
torique —*

Partie 1: Orifices à joint torique dans un logement tronconique



Reference number
ISO 11926-1:1995(E)

Foreword

ISO (the International Organization for Standardization) is a worldwide federation of national standards bodies (ISO member bodies). The work of preparing International Standards is normally carried out through ISO technical committees. Each member body interested in a subject for which a technical committee has been established has the right to be represented on that committee. International organizations, governmental and non-governmental, in liaison with ISO, also take part in the work. ISO collaborates closely with the International Electrotechnical Commission (IEC) on all matters of electrotechnical standardization.

Draft International Standards adopted by the technical committees are circulated to the member bodies for voting. Publication as an International Standard requires approval by at least 75 % of the member bodies casting a vote.

International Standard ISO 11926-1 was prepared jointly by Technical Committees ISO/TC 131, *Fluid power systems*, Subcommittee SC 4, *Connectors and similar products and components* and ISO/TC 5, *Ferrous metal pipes and metallic fittings*.

ISO 11926 consists of the following parts, under the general title *Connections for general use and fluid power — Ports and stud ends with ISO 725 threads and O-ring sealing*:

- Part 1: *Ports with O-ring seal in truncated housing*
- Part 2: *Heavy-duty (S series) stud ends*
- Part 3: *Light-duty (L series) stud ends*

Annex A of this part of ISO 11926 is for information only.

© ISO 1995

All rights reserved. Unless otherwise specified, no part of this publication may be reproduced or utilized in any form or by any means, electronic or mechanical, including photocopying and microfilm, without permission in writing from the publisher.

International Organization for Standardization
Case Postale 56 • CH-1211 Genève 20 • Switzerland

Printed in Switzerland

Introduction

In fluid power systems, power is transmitted and controlled through a fluid (liquid or gas) under pressure within an enclosed circuit. In general applications, a fluid may be conveyed under pressure.

Components are connected through their threaded ports by fluid connector fittings to tubes and pipes or to hose fittings and hoses.

Ports are an integral part of fluid power components such as pumps, motors, valves, cylinders, etc.

iTeh STANDARD PREVIEW (standards.iteh.ai)

[ISO 11926-1:1995](https://standards.iteh.ai/catalog/standards/sist/7ec0f7ea-fbfc-4c4d-82d8-4ad129b4be10/iso-11926-1-1995)

<https://standards.iteh.ai/catalog/standards/sist/7ec0f7ea-fbfc-4c4d-82d8-4ad129b4be10/iso-11926-1-1995>

iTeh STANDARD PREVIEW
This page intentionally left blank
(standards.iteh.ai)

ISO 11926-1:1995

<https://standards.iteh.ai/catalog/standards/sist/7ec0f7ea-fbfc-4c4d-82d8-4ad129b4be10/iso-11926-1-1995>

Connections for general use and fluid power — Ports and stud ends with ISO 725 threads and O-ring sealing —

Part 1: Ports with O-ring seal in truncated housing

1 Scope

This part of ISO 11926 specifies dimensions for ports with inch threads complying with ISO 725 for use with the adjustable and non-adjustable stud ends detailed in ISO 11926-2 and ISO 11926-3. It also specifies test methods and the designation of these ports.

Ports in accordance with this part of ISO 11926 may be used at working pressures up to 63 MPa (630 bar¹⁾) for non-adjustable stud ends, and 40 MPa (400 bar) for adjustable stud ends. The permissible working pressure depends upon the port size, materials, design, working conditions, application, etc.

For threaded ports and stud ends specified in new designs in hydraulic fluid power applications, only ISO 6149 is to be used. Threaded ports and stud ends in accordance with ISO 1179, ISO 9974 and ISO 11926 are not to be used for new designs in hydraulic fluid power applications.

2 Normative references

The following standards contain provisions which, through reference in this text, constitute provisions of this part of ISO 11926. At the time of publication, the editions indicated were valid. All standards are subject to revision, and parties to agreements based on this part of ISO 11926 are encouraged to investigate the possibility of applying the most recent editions of the standards indicated below. Members of

IEC and ISO maintain registers of currently valid International Standards.

ISO 725:1978, *ISO inch screw threads — Basic dimensions*.

ISO 2306:1972, *Drills for use prior to tapping screw threads*.

ISO 5598:1985, *Fluid power systems and components — Vocabulary*.

ISO 11926-2:1995, *Connections for general use and fluid power — Ports and stud ends with ISO 725 threads and O-ring sealing — Part 2: Heavy-duty (S series) stud ends*.

ISO 11926-3:1995, *Connections for general use and fluid power — Ports and stud ends with ISO 725 threads and O-ring sealing — Part 3: Light-duty (L series) stud ends*.

3 Definitions

For the purposes of this part of ISO 11926, the definitions given in ISO 5598 apply.

4 Dimensions

Ports shall conform to the dimensions shown in figure 1 and given in table 1.

1) 1 bar = 0,1 MPa = 10⁵ Pa; 1 MPa = 1 N/mm²

5 Test methods

Ports shall be tested along with stud ends in accordance with the test methods and requirements given in ISO 11926-2 and ISO 11926-3.

6 Designation of ports

The ports shall be designated by

- a) "Port";
- b) reference to this part of ISO 11926, i.e. ISO 11926-1;
- c) thread size (d_1) and number of threads per inch (n), separated by a hyphen, without indicating the

fine thread series (UNF) or the constant-pitch series (UN) and the thread class symbol (2B).

EXAMPLE

Port ISO 11926-1 - 1/2 - 20

7 Identification statement (Reference to this part of ISO 11926)

Use the following statement in test reports, catalogues and sales literature when electing to comply with this part of ISO 11926:

"Ports conform to ISO 11926-1:1995, *Connections for general use and fluid power — Ports and stud ends with ISO 725 threads and O-ring sealing — Part 1: Ports with O-ring seal in truncated housing.*"

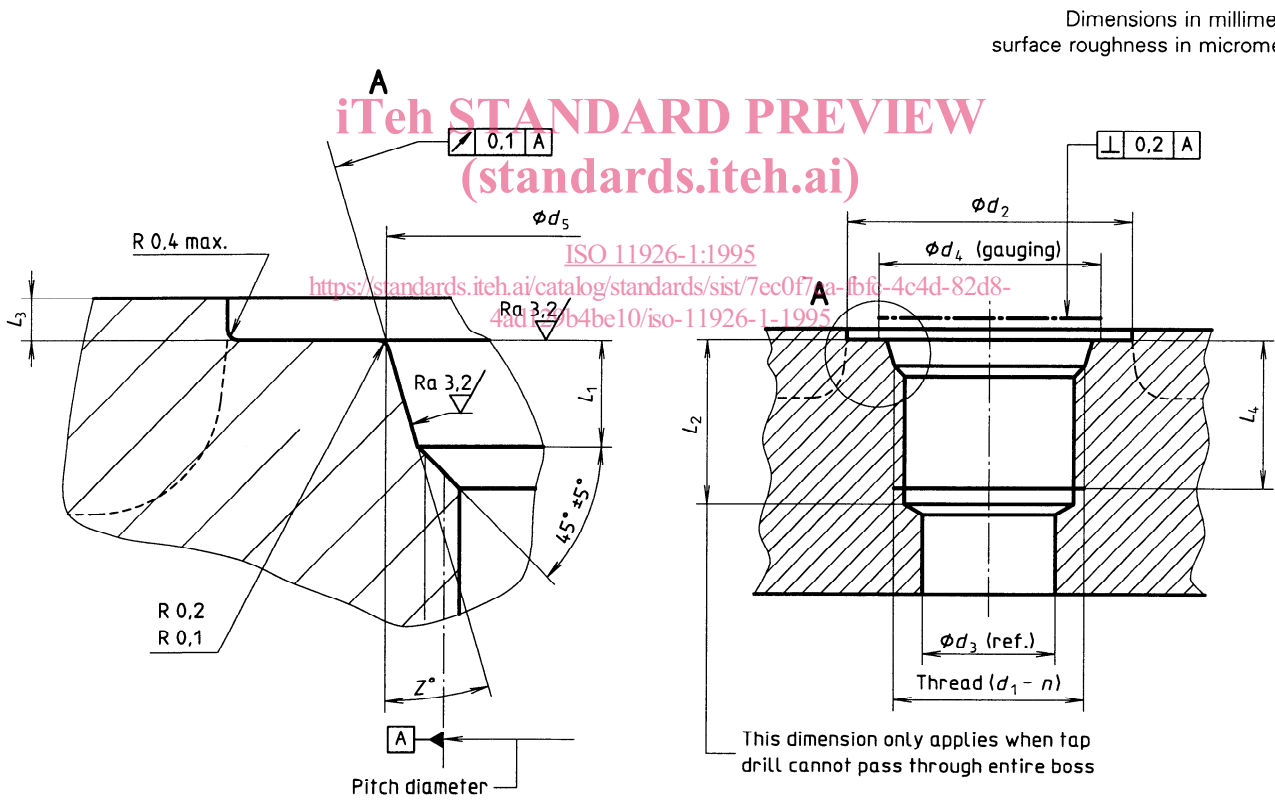

Dimensions in millimetres, surface roughness in micrometres

Figure 1 — Port

Table 1 — Port dimensions

Dimensions in millimetres

Thread ¹⁾ ($d_1 - n$)	d_2 ²⁾ min.	d_3 ³⁾ ref.	d_4 min.	d_5 $\pm 0,05$	L_1 $\begin{smallmatrix} +0,4 \\ 0 \end{smallmatrix}$	L_2 ⁴⁾ min.	L_3 ⁵⁾ max.	L_4 min.	Z° $\pm 1^\circ$
3/8-24 UNF-2B	19	3,5	13	10,75	1,9	12	1,6	10	12
7/16-20 UNF-2B	21	4,5	15	12,45	2,4	14	1,6	11,5	12
1/2-20 UNF-2B	23	6	16	14,05	2,4	14	1,6	11,5	12
9/16-18 UNF-2B	25	7,5	18	15,7	2,5	15,5	1,6	12,7	12
3/4-16 UNF-2B	30	10	22	20,65	2,5	17,5	2,4	14,3	15
7/8-14 UNF-2B	34	12,5	26	24	2,5	20	2,4	16,7	15
1 1/16-12 UN-2B	41	16	32	29,2	3,3	23	2,4	19	15
1 3/16-12 UN-2B	45	18	35	32,4	3,3	23	2,4	19	15
1 5/16-12 UN-2B	49	21	38	35,55	3,3	23	3,2	19	15
1 5/8-12 UN-2B	58	27	48	43,55	3,3	23	3,2	19	15
1 7/8-12 UN-2B	65	33	54	49,9	3,3	23	3,2	19	15
2 1/2-12 UN-2B	88	45	70	65,75	3,3	23	3,2	19	15

1) Conforming to ISO 725. Tap drills in accordance with ISO 2306.

2) Minimum recommended spotface diameter. If the face of the port is on a machined surface, dimensions d_2 and L_3 need not apply as long as radius $R_{0,2}$ is maintained to avoid damage to the O-ring during installation.

3) For reference only. Connecting hole application may require a different size.

4) The tap drill depths given require the use of a bottoming tap to produce the specified full thread lengths. Where standard taps are used, the tap drill depths shall be increased accordingly.

5) Maximum recommended spotface depth to permit sufficient wrench grip for proper tightening of the fitting or locknut.

Annex A

(informative)

Bibliography

- [1] ISO 263:1973, *ISO inch screw threads — General plan and selection for screws, bolts and nuts — Diameter range 0.06 to 6 in.*
- [2] ISO 1101:1983, *Technical drawings — Geometrical tolerancing — Tolerancing of form, orientation, location and run-out — Generalities, definitions, symbols, indications on drawings.*
- [3] ISO 1179-1:—²⁾, *Connections for general use and fluid power — Ports and stud ends with ISO 228-1 threads with elastomeric or metal-to-metal sealing — Part 1: Threaded ports.*
- [4] ISO 1179-2:—²⁾, *Connections for general use and fluid power — Ports and stud ends with ISO 228-1 threads with elastomeric or metal-to-metal sealing — Part 2: Heavy-duty (S series) and light-duty (L series) stud ends with elastomeric sealing (type E).*
- [5] ISO 1179-3:—²⁾, *Connections for general use and fluid power — Ports and stud ends with ISO 228-1 threads with elastomeric or metal-to-metal sealing — Part 3: Light-duty (L series) stud ends with sealing by O-ring with retaining ring (types G and H).*
- [6] ISO 1179-4:—²⁾, *Connections for general use and fluid power — Ports and stud ends with ISO 228-1 threads with elastomeric or metal-to-metal sealing — Part 4: Stud ends for general use only with metal-to-metal sealing (type B).*
- [7] ISO 1302:1992, *Technical drawings — Method of indicating surface texture.*
- [8] ISO 6149-1:1993, *Connections for fluid power and general use — Ports and stud ends with ISO 261 threads and O-ring sealing — Part 1: Ports with O-ring seal in truncated housing.*
- [9] ISO 6149-2:1993, *Connections for fluid power and general use — Ports and stud ends with ISO 261 threads and O-ring sealing — Part 2: Heavy-duty (S series) stud ends — Dimensions, design, test methods and requirements.*
- [10] ISO 6149-3:1993, *Connections for fluid power and general use — Ports and stud ends with ISO 261 threads and O-ring sealing — Part 3: Light-duty (L series) stud ends — Dimensions, design, test methods and requirements.*
- [11] ISO 6410-1:1993, *Technical drawings — Screw threads and threaded parts — Part 1: General conventions.*
- [12] ISO 9974-1:—²⁾, *Connections for general use and fluid power — Ports and stud ends with ISO 261 threads with elastomeric or metal-to-metal sealing — Part 1: Threaded ports.*
- [13] ISO 9974-2:—²⁾, *Connections for general use and fluid power — Ports and stud ends with ISO 261 threads with elastomeric or metal-to-metal sealing — Part 2: Stud ends with elastomeric sealing (type E).*
- [14] ISO 9974-3:—²⁾, *Connections for general use and fluid power — Ports and stud ends with ISO 261 threads with elastomeric or metal-to-metal sealing — Part 3: Stud ends with metal-to-metal sealing (type B).*

2) To be published.

iTeh STANDARD PREVIEW
This page intentionally left blank
(standards.iteh.ai)

ISO 11926-1:1995

<https://standards.iteh.ai/catalog/standards/sist/7ec0f7ea-fbfc-4c4d-82d8-4ad129b4be10/iso-11926-1-1995>