

INTERNATIONAL
STANDARD

ISO
2982-2

First edition
1995-09-01

Rolling bearings — Accessories —

Part 2:

Locknuts and locking devices — Dimensions

iTeh STANDARD PREVIEW

(standards.iteh.ai)

Roulements — Accessoires —

Partie 2: Écrous à encoches et dispositifs de blocage — Dimensions

<https://standards.iteh.ai/catalog/standards/sist/7c2c135c-d3a6-4470-8d0d-343b30bcd93c/iso-2982-2-1995>



Reference number
ISO 2982-2:1995(E)

Foreword

ISO (the International Organization for Standardization) is a worldwide federation of national standards bodies (ISO member bodies). The work of preparing International Standards is normally carried out through ISO technical committees. Each member body interested in a subject for which a technical committee has been established has the right to be represented on that committee. International organizations, governmental and non-governmental, in liaison with ISO, also take part in the work. ISO collaborates closely with the International Electrotechnical Commission (IEC) on all matters of electrotechnical standardization.

Draft International Standards adopted by the technical committees are circulated to the member bodies for voting. Publication as an International Standard requires approval by at least 75 % of the member bodies casting a vote.

International Standard ISO 2982-2 was prepared by Technical Committee ISO/TC 4, *Rolling bearings*.

This first edition of ISO 2982-2 cancels and replaces ISO 2982:1972, which has been technically revised.

ISO 2982 consists of the following parts, under the general title *Rolling bearings — Accessories*:

- *Part 1: Tapered sleeves — Dimensions*
- *Part 2: Locknuts and locking devices — Dimensions*

© ISO 1995

All rights reserved. Unless otherwise specified, no part of this publication may be reproduced or utilized in any form or by any means, electronic or mechanical, including photocopying and microfilm, without permission in writing from the publisher.

International Organization for Standardization
Case Postale 56 • CH-1211 Genève 20 • Switzerland

Printed in Switzerland

Rolling bearings — Accessories —

Part 2:

Locknuts and locking devices — Dimensions

iTeh STANDARD PREVIEW (standards.iteh.ai)

1 Scope

This part of ISO 2982 specifies dimensions for locknuts and locking devices for tapered sleeves in accordance with ISO 2982-1.

In particular,

- locknuts for adapter sleeves and for axial location of bearing inner rings on shafts; they are also suitable for dismounting of withdrawal sleeves;
- lockwashers with straight inner tab with 4-slot locknuts for adapter sleeves;
- locking clip assemblies with 8-slot locknuts for adapter sleeves.

2 Normative reference

The following standard contains provisions which, through reference in this text, constitute provisions of this part of ISO 2982. At the time of publication, the edition indicated was valid. All standards are subject to revision, and parties to agreements based on this part of ISO 2982 are encouraged to investigate the possibility of applying the most recent edition of the standard indicated below. Members of IEC and ISO maintain registers of currently valid International Standards.

ISO 2982-1:1995, *Rolling bearings — Accessories — Part 1: Tapered sleeves — Dimensions*.

3 Symbols and dimensions

The dimensions given in tables 1 to 4, corresponding to the symbols shown in figures 1 to 4, are nominal dimensions unless specified otherwise.

3.1 Locknuts (4 slots) and lockwashers

See figures 1 and 2 and tables 1 and 2.

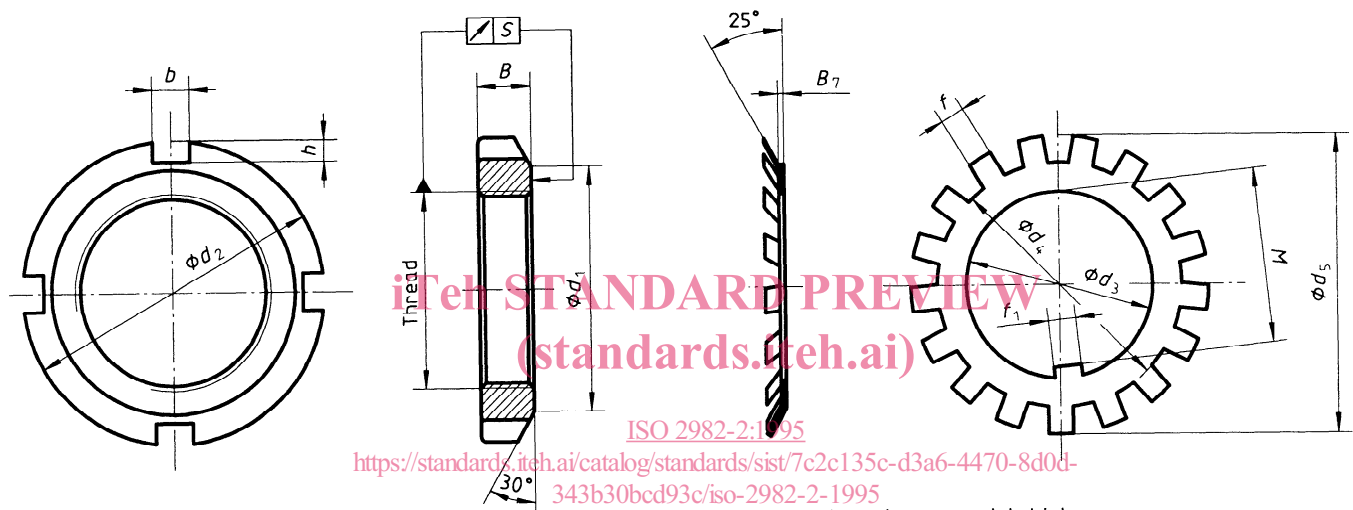

- b = width of locknut slot
- B = locknut width
- d_1 = outside diameter of locknut clamp face
- d_2 = outside diameter of locknut
- h = depth of locknut slot
- S = run-out tolerance of locknut clamp face with respect to the thread pitch diameter

- B_7 = lockwasher material thickness
- d_3 = bore diameter of lockwasher
- d_4 = root diameter of lockwasher outer tab
- d_5 = outside diameter of lockwasher
- f = width of lockwasher outer tab
- f_1 = width of lockwasher inner tab
- M = d_3 – height of inner tab
- N = number of lockwasher outer tabs

Figure 1 — Locknut (4 slots)

Figure 2 — Lockwasher

Table 1 — Locknuts (4 slots)

Dimensions in millimetres

Thread ¹⁾	d_2	d_1	B	b	h	S 2)
M10 × 0,75	18	13,5	4	3	2	0,04
M12 × 1	22	17	4	3	2	
M15 × 1	25	21	5	4	2	
M17 × 1	28	24	5	4	2	
M20 × 1	32	26	6	4	2	
M25 × 1,5	38	32	7	5	2	
M30 × 1,5	45	38	7	5	2	
M35 × 1,5	52	44	8	5	2	
M40 × 1,5	58	50	9	6	2,5	
M45 × 1,5	65	56	10	6	2,5	
M50 × 1,5	70	61	11	6	2,5	
M55 × 2	75	67	11	7	3	
M60 × 2	80	73	11	7	3	
M65 × 2	85	79	12	7	3	
M70 × 2	92	85	12	8	3,5	
M75 × 2	98	90	13	8	3,5	
M80 × 2	105	95	15	8	3,5	
M85 × 2	110	102	16	8	3,5	
M90 × 2	120	108	16	10	4	
M95 × 2	125	113	17	10	4	
M100 × 2	130	120	18	10	4	
M105 × 2	140	126	18	12	5	
M110 × 2	145	133	19	12	5	
M115 × 2	150	137	19	12	5	
M120 × 2	145	135	20	12	5	
M120 × 2	155	138	20	12	5	
M125 × 2	160	148	21	12	5	
M130 × 2	155	145	21	12	5	
M130 × 2	165	149	21	12	5	
M135 × 2	175	160	22	14	6	
M140 × 2	165	155	22	12	5	
M140 × 2	180	160	22	14	6	
M145 × 2	190	171	24	14	6	
M150 × 2	180	170	24	14	5	
M150 × 2	195	171	24	14	6	
M155 × 3	200	182	25	16	7	
M160 × 3	190	180	25	14	5	
M160 × 3	210	182	25	16	7	
M165 × 3	210	193	26	16	7	
M170 × 3	200	190	26	16	5	
M170 × 3	220	193	26	16	7	
M180 × 3	210	200	27	16	5	
M180 × 3	230	203	27	18	8	
M190 × 3	220	210	28	16	5	
M190 × 3	240	214	28	18	8	
M200 × 3	240	222	29	18	8	
M200 × 3	250	226	29	18	8	
Tr210 × 4	270	238	30	20	10	
Tr220 × 4	280	250	32	20	10	
Tr230 × 4	290	260	34	20	10	
Tr240 × 4	300	270	34	20	10	
Tr250 × 4	320	290	36	20	10	
Tr260 × 4	330	300	36	24	12	
Tr280 × 4	350	320	38	24	12	

1) Tolerance class 5H for metric threads and 7H for metric trapezoidal threads.

2) Measurements taken at a radius = $\frac{\text{thread outside diameter} + d_1}{4}$

Table 2 — Lockwashers

Dimensions in millimetres

d_3	d_4	d_5	f_1	M	f 1)	B , 2)	N 3)
		≈	max.			≈	
10	13,5	21	3	8,5	3	1	9
12	17	25	3	10,5	3	1	11
15	21	28	4	13,5	4	1	
17	24	32	4	15,5	4	1	13
20	26	36	4	18,5	4	1	
25	32	42	5	23	5	1,25	
30	38	49	5	27,5	5	1,25	
35	44	57	6	32,5	5	1,25	
40	50	62	6	37,5	6	1,25	
45	56	69	6	42,5	6	1,25	17
50	61	74	6	47,5	6	1,25	
55	67	81	8	52,5	7	1,5	
60	73	86	8	57,5	7	1,5	
65	79	92	8	62,5	7	1,5	
70	85	98	8	66,5	8	1,5	
75	90	104	8	71,5	8	1,5	
80	95	112	10	76,5	8	1,8	
85	102	119	10	81,5	8	1,8	
90	108	126	10	86,5	10	1,8	
95	113	133	10	91,5	10	1,8	
100	120	142	12	96,5	10	1,8	
105	126	145	12	100,5	12	1,8	
110	133	154	12	105,5	12	1,8	
115	137	159	12	110,5	12	2	
120	135	151	14	115	12	2	
120	138	164	14	115	12	2	
125	148	170	14	120	12	2	
130	145	161	14	125	12	2	
130	149	175	14	125	12	2	
135	160	185	14	130	14	2	
140	155	171	16	135	12	2	
140	160	192	16	135	14	2	
145	171	202	16	140	14	2	
150	170	188	16	145	14	2	
150	171	205	16	145	14	2	
155	182	212	16	147,5	16	2,5	
160	180	199	18	154	14	2,5	
160	182	217	18	154	16	2,5	
165	193	222	18	157,5	16	2,5	
170	190	211	18	164	16	2,5	
170	193	232	18	164	16	2,5	
180	200	221	20	174	16	2,5	
180	203	242	20	174	18	2,5	
190	210	231	20	184	16	2,5	
190	214	252	20	184	18	2,5	
200	222	248	20	194	18	2,5	
200	226	262	20	194	18	2,5	
210	—	—	—	—	—	—	
220	250	292	24	213	20	3	
230	—	—	—	—	—	—	
240	270	312	24	233	20	3	
250	—	—	—	—	—	—	
260	300	342	28	253	24	3	
280	320	362	28	273	24	3	

1) f must be $< b$ (see figure 1 and table 1).

2) The thickness is only approximate, and small variations are permissible.

3) N = minimum number of outer tabs; since the locknut has 4 slots, N must be an odd number.

3.2 Locknuts (8 slots) and locking clip assemblies

See figures 3 and 4 and tables 3 and 4.

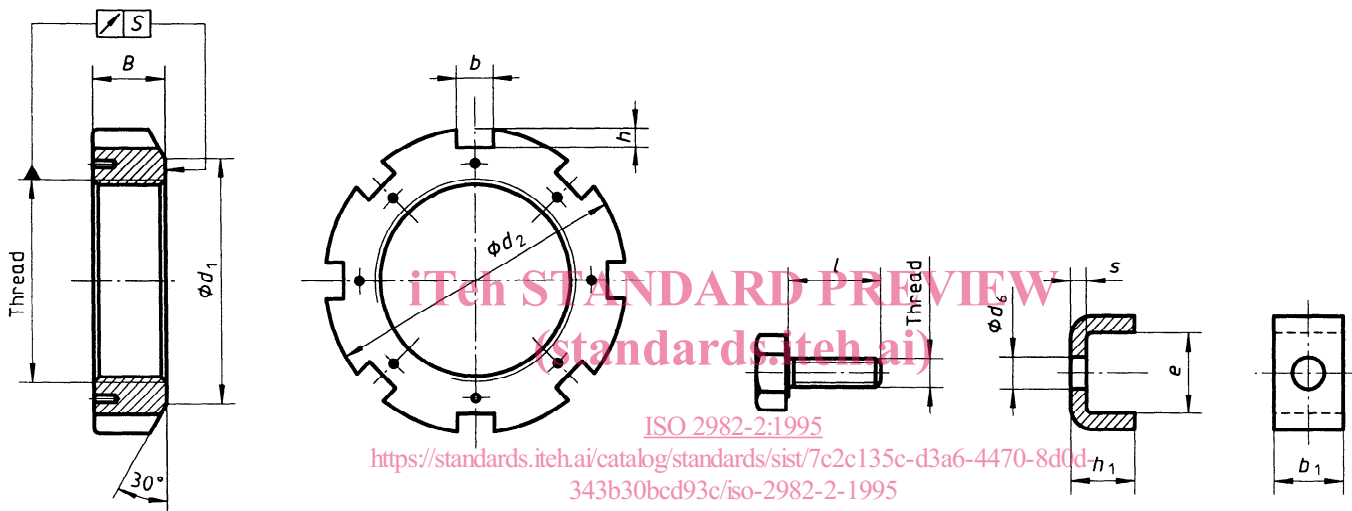

- b = width of locknut slot
- B = locknut width
- d_1 = outside diameter of locknut clamp face
- d_2 = outside diameter of locknut
- h = depth of locknut slot
- S = run-out of locknut clamp face with respect to the thread pitch diameter

- b_1 = locking clip width
 - d_6 = diameter of locking clip hole
 - e = inner width of locking clip
 - h_1 = locking clip height
 - l = length of screw
 - s = locking clip material thickness
- NOTE — The screw may or may not be secured.

Figure 3 — Locknut (8 slots)

Figure 4 — Locking clip assembly

Table 3 — Locknuts (8 slots)

Dimensions in millimetres

Thread ¹⁾	d_2	d_1	B	b	h	s 2)	Suitable locking clip No.
Tr220 × 4	260	242	30	20	9		1
Tr240 × 4	290	270	34	20	10		2
Tr260 × 4	310	290	34	20	10		2
Tr280 × 4	330	310	38	24	10		3
Tr300 × 4	360	336	42	24	12		4
Tr300 × 4	380	340	40	24	12		5
Tr320 × 5	380	356	42	24	12		6
Tr320 × 5	400	360	42	24	12		7
Tr340 × 5	400	376	45	24	12	0,12	6
Tr340 × 5	440	400	55	28	15		8
Tr360 × 5	420	394	45	28	13		9
Tr360 × 5	460	420	58	28	15		8
Tr380 × 5	450	422	48	28	14		10
Tr380 × 5	490	440	60	32	18		11
Tr400 × 5	470	442	52	28	14		10
Tr400 × 5	520	460	62	32	18		12
Tr420 × 5	490	462	52	32	14		13
Tr420 × 5	540	490	70	32	18		12
Tr440 × 5	520	490	60	32	15		14
Tr440 × 5	560	510	70	36	20		15
Tr460 × 5	540	510	60	32	15		14
Tr460 × 5	580	540	75	36	20		15
Tr480 × 5	560	530	60	36	15		16
Tr480 × 5	620	560	75	36	20		17
Tr500 × 5	580	550	68	36	15	0,15	16
Tr500 × 5	630	580	80	40	23		18
Tr530 × 6	630	590	68	40	20		19
Tr530 × 6	670	610	80	40	23		20
Tr560 × 6	650	610	75	40	20		21
Tr560 × 6	710	650	85	45	25		22
Tr600 × 6	700	660	75	40	20		19
Tr600 × 6	750	690	85	45	25		22
Tr630 × 6	730	690	75	45	20		23
Tr630 × 6	800	730	95	50	28		24
Tr670 × 6	780	740	80	45	20		25
Tr670 × 6	850	775	106	50	28		26
Tr710 × 7	830	780	90	50	25		27
Tr710 × 7	900	825	106	55	30		28
Tr750 × 7	870	820	90	55	25		29
Tr750 × 7	950	875	112	60	34		30
Tr800 × 7	920	870	90	55	25		29
Tr800 × 7	1 000	925	112	60	34		30
Tr850 × 7	980	925	90	60	25		31
Tr850 × 7	1 060	975	118	70	38	0,2	32
Tr900 × 7	1 030	975	100	60	25		31
Tr900 × 7	1 120	1 030	125	70	38		33
Tr950 × 8	1 080	1 025	100	60	25		34
Tr950 × 8	1 170	1 080	125	70	38		35
Tr1000 × 8	1 140	1 085	100	60	25		36
Tr1000 × 8	1 240	1 140	125	70	38		37
Tr1060 × 8	1 200	1 145	100	60	25		36
Tr1060 × 8	1 300	1 210	125	70	38		37
Tr1120 × 8	1 260	1 205	100	60	25		36

1) Tolerance class 7H for metric trapezoidal threads.

2) Measurements taken at a radius $r = \frac{\text{thread outside diameter} + d_1}{4}$

Table 4 — Locking clip assemblies

Dimensions in millimetres

Locking clip No.	s 1) ≈	b_1 2)	h_1	e	d_6	l 3) ≈	Thread
1	4	20	12	13,5	7	12	M6
2	4	20	12	17,5	9	16	M8
3	4	24	12	17,5	9	16	M8
4	4	24	12	20,5	9	16	M8
5	4	24	12	30,5	12	20	M10
6	5	24	15	21	9	16	M8
7	5	24	15	31	12	20	M10
8	5	28	15	38	14	25	M12
9	5	28	15	20	9	16	M8
10	5	28	15	24	12	20	M10
11	5	32	15	40	14	25	M12
12	5	32	15	45	18	30	M16
13	5	32	15	24	12	20	M10
14	5	32	15	28	14	25	M12
15	5	36	15	43	18	30	M16
16	5	36	15	28	14	25	M12
17	5	36	15	53	18	30	M16
18	5	40	15	45	18	30	M16
19	7	40	21	34	18	30	M16
20	7	40	21	51	22	40	M20
21	7	40	21	29	18	30	M16
22	7	45	21	54	22	40	M20
23	7	45	21	34	18	30	M16
24	7	50	21	61	22	40	M20
25	7	45	21	39	18	30	M16
26	7	50	21	66	22	40	M20
27	7	50	21	39	18	30	M16
28	7	55	21	69	26	50	M24
29	7	55	21	39	18	30	M16
30	7	60	21	70	26	50	M24
31	7	60	21	44	22	40	M20
32	7	70	21	71	26	50	M24
33	7	70	21	76	26	50	M24
34	7	60	21	46	22	40	M20
35	7	70	21	78	26	50	M24
36	7	60	21	51	22	40	M20
37	7	70	21	88	26	50	M24

1) The thickness is only approximate, and small variations are permissible.

2) b_1 must be $< b$ (see figure 3 and table 3).

3) The lengths shown correspond to preferred screw lengths for the screw sizes listed; variations are however permissible.

iTeh STANDARD PREVIEW
(standards.iteh.ai)

ISO 2982-2:1995

<https://standards.iteh.ai/catalog/standards/sist/7c2c135c-d3a6-4470-8d0d-343b30bcd93c/iso-2982-2-1995>

ICS 21.100.20

Descriptors: bearings, rolling bearings, accessories, locknuts, lock washers, dimensions, dimensional tolerances.

Price based on 5 pages
